

ALGEMENE KENMERKEN:

Wafer type vlinderklep

Huis in nodulair gietijzer, Rilsan gecoat (230µ ~ 300µ), klep in roestvast staal, zitting in EPDM Wit

Inbouw lengte: ISO 5752

Tussenbouw tussen flenzen DIN PN 10, DIN PN 16 en ANSI 150

Opbouw flens: ISO 5211

BEDRIJFSOMSTANDIGHEDEN:

Voor drukken tot 16 bar (10 bar vanaf DN 350)

en temperaturen van -10 °C tot 90 °C



ONTWERP	
Vlinderklep	ISO 5752, API 609
Volgens	DIN 3202, API 609, BS EN 558
Opbouw flens	ISO 5211
Markering	ISO 5209
TESTEN EN CERTIFICATEN	
PED/CE	97/23/EC
Druktest	API 598

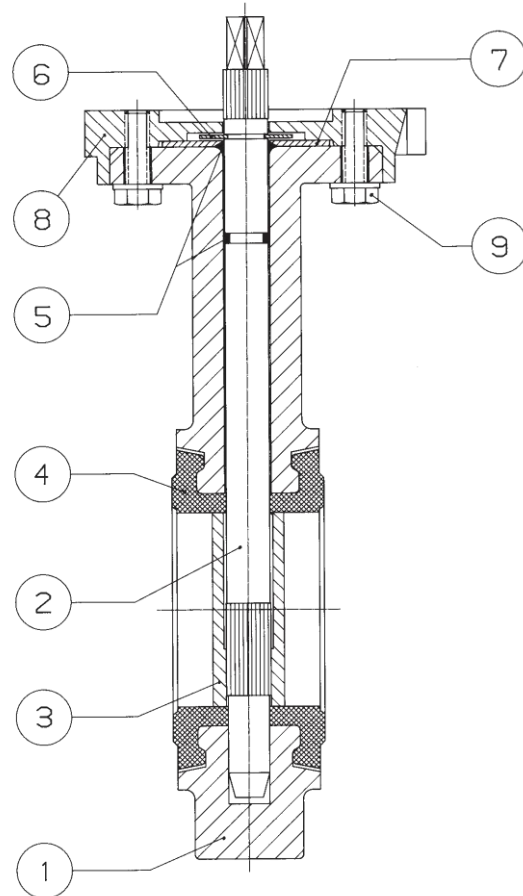

MATERIALEN:

Pos.	Omschrijving	Materialen
1	Huis	Nodulair gietijzer GJS-500-7
2	Spindel	Roestvast staal AISI 303
3	Klep	Roestvast staal AISI 316
4	Zitting	EPDM Wit
5	O-ring	Nitril rubber
6	Circlip	Staal
7	Washer	Staal
8	Opbouwflens	Aluminium
9	Bout	DIN 933 5.6
10	Hendel	Aluminium (DN32 - DN 200)
		Gietstaal (DN250 - DN300)
		Vrij aseind vanaf DN350

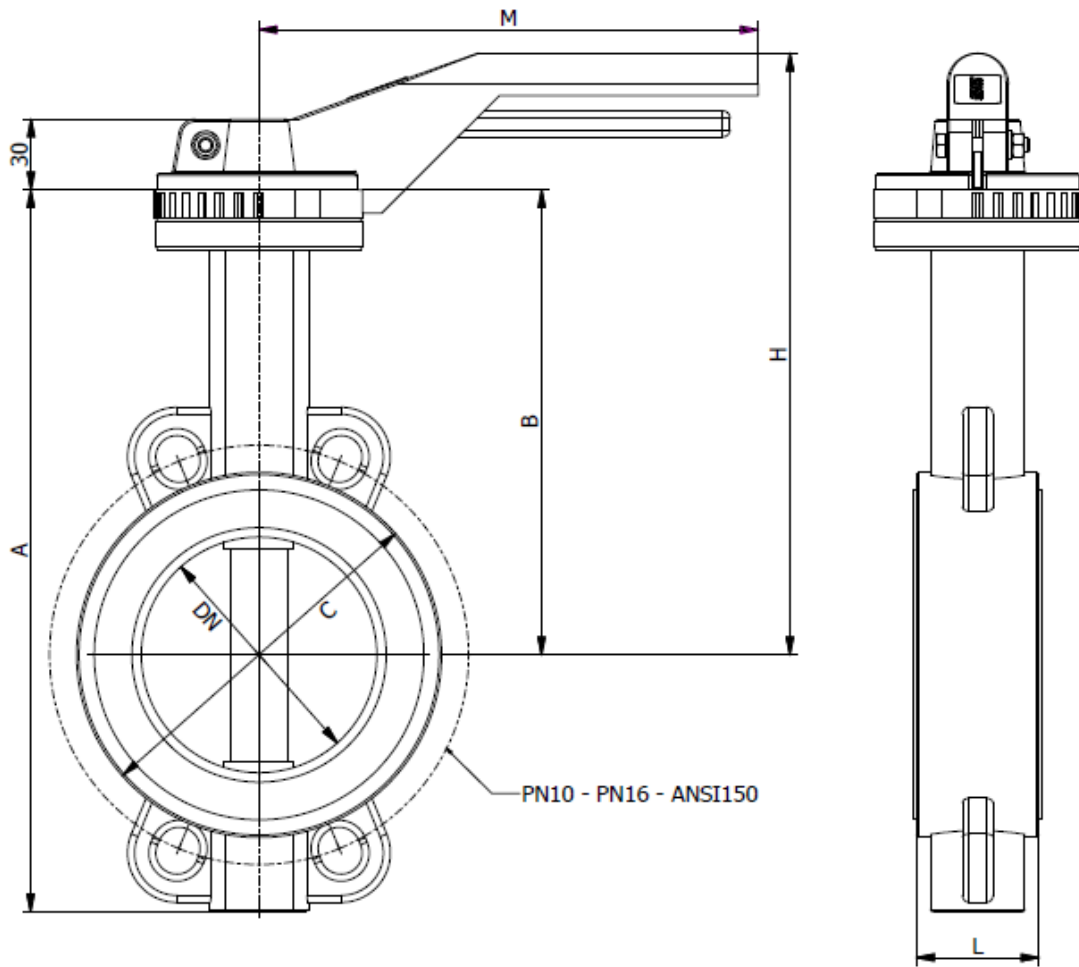

AFMETINGEN: (mm)

DN	Ø	A	B	C	L	M	H	PN 10		PN 16		ANSI 150		Kg
								K	N x T	K	N x T	K	N x T	
32	1 1/4"	206	140	82	33	212	198	100	4x 18	100	4x 18	88,9	4x 16	2,0
40	1 1/2"	206	140	82	33	212	198	110	4x 18	110	4x 18	98,5	4x 16	2,0
50	2"	228	156	102	43	212	214	125	4x 18	125	4x 18	120,6	4x 19	3,5
65	2 1/2"	243	162	119	46	212	220	145	4x 18	145	4x 18	139,7	4x 19	4,5
80	3"	266	170	135	46	212	228	160	4x 18	160	4x 18	152,4	4x 19	5,0
100	4"	294	185	155	52	212	243	180	4x 18	180	4x 18	190,5	4x 19	6,5
125	5"	324	207	185	56	329	278	210	4x 18	210	4x 18	215,9	4x 23	8,0
150	6"	349	216	208	56	329	286	240	4x 23	240	4x 23	241,3	4x 23	9,0
200	8"	438	256	270	60	329	326	295	4x 23	295	4x 23	298,5	4x 23	15,0
250	10"	461	248	328	68	600	600	350	4x 23	355	4x 27	362,0	4x 26	21,5
300	12"	523	280	381	78	600	600	400	4x 23	410	4x 27	431,8	4x 26	30,0
350	14"	582	300	437	78	-	-	460	4x 23	470	4x 27	476,3	4x 29	39,0
400	16"	645	340	486	102	-	-	515	4x 27	525	4x 30	539,8	4x 29	52,0

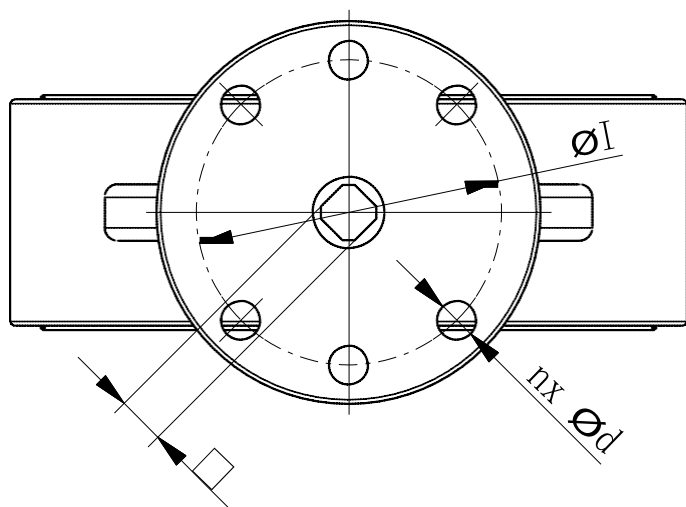

DN	Ø	ØI	nx Ød	J	ISO5211
32	1 1/4"	70	4x 9	8	F07
40	1 1/2"	70	4x 9	8	F07
50	2"	70	4x 9	8	F07
65	2 1/2"	70	4x 9	9	F07
80	3"	70	4x 9	11	F07
100	4"	70	4x 9	11	F07
125	5"	70	4x 9	14	F07
150	6"	70	4x 9	14	F07
200	8"	70	4x 9	17	F07
250	10"	102	4x 11	19	F10
300	12"	102	4x 11	22	F10
350	14"	140	4x 18	22	F14
400	16"	140	4x 18	27	F14

Kv-WAARDEN, LOSBREEKMOMENT:

DN	Ø	Kv (m³/h)	T (Nm) 16 bar
32	1 1/4"	70	9
40	1 1/2"	70	9
50	2"	111	11
65	2 1/2"	201	20
80	3"	335	29
100	4"	552	47
125	5"	901	82
150	6"	1427	130
200	8"	2392	210
250	10"	3826	360
300	12"	5660	475
350	14"	8179	760
400	16"	10660	1300

De aangeduide waarden zijn geldig voor water bij omgevingstemperatuur