

**PRESSURE OPERATED PUMP
ADCAMAT POP-S**

DESCRIPTION

The ADCAMAT POP (Pressure Operated Pump) fabricated carbon steel (stainless steel on request) is recommended in the transfer of high-temperature liquids such as condensate, oils and other liquids to a higher elevation or pressure.

The pump starts when there is something to pump and stops when there isn't.

Under certain conditions, it can drain a closed vessel under vacuum or pressure.

The pump can be operated by steam, compressed air or gas and can be used for lifting any kind of non-corrosive liquids.

Connections are flanged or female screwed (with screwed flanges).



FUNCTION

Liquid flows by gravity into the pump through an inlet check valve lifting a float which, at the upper limit of its travel, opens the supply valve which allows steam or compressed air to enter the pump body. Pressure in the pump builds up until just sufficient to overcome back pressure.

The pressurized liquid opens the outlet check valve and discharge commences. When the float reaches the minimum lower level it closes the steam or compressed air supply valve and opens the vent, allowing the liquid to fill the pump again.

As the amount of liquid discharged at each stroke is known, the total volume passed during a given period can be calculated by counting the number of strokes during that period. For this purpose a special counter is available which screws into a tapped connection on the top cover of the pump. This counter records the number of pumping strokes thus enabling the pump to function as a reliable flow meter.

MAIN FEATURES : Non-electric requirements.

OPTIONS: Stainless steel construction.
Level gauge.
Stroke counter.

USE : To lift condensate or hot and cold liquids.

AVAILABLE MODELS : ADCAMAT POP-S - carbon steel construction
ADCAMAT POP-SS - Stainless steel construction
(Carbon steel version is sandblasted, metallized and black painted).

SIZES : DN 25 ; DN 40 ; DN 50 ; DN 80 x 50.

CONNECTIONS : Flanged EN1092-1 PN16. Special flanges upon request. Female screwed ISO 7/1 Rp (BS21).

INSTALLATION : Horizontal installation.
See IMI installation and maintenance instructions.

MOTIVE GAS : Steam or compressed air.

CE Marking :

This product has been designed for use on water, steam, air and other gases which are in Group 2 of the PED - European Pressure Equipment Directive 97/23/EC and it complies with those requirements. All the sizes fall within category 2. The product carries the CE mark.

APPLICATION LIMITS

Minimum density	0,80 kg/dm3
Maximum viscosity	5° Engler
Maximum motive pressure	10 bar
Minimum motive pressure	0,5 bar
Pump discharge per cycle DN25 to DN50	16 l
Pump discharge per cycle DN80 x DN50	25 l

LIMITING CONDITIONS *

		POP-S		POP-SS	
	Press. bar	Temp. °C		Press. bar	Temp. °C
PN16	16	50	PN16	16	50
	14	100		16	100
	13	195		13	195
	12	250		12	250
ANSI Cl.150	16	50	ANSI Cl.150	16	50
	13	195		13	195

Minimum operating temp.: -10°C; Design code: ASME VIII

* Rating according to EN1092:2007

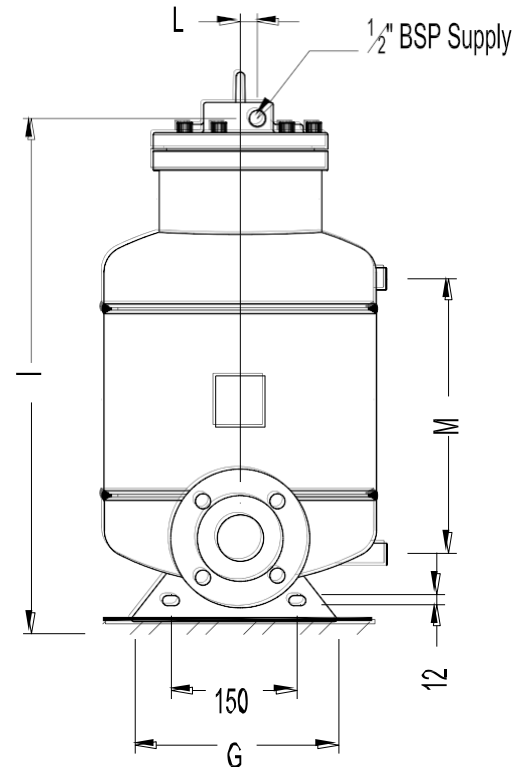
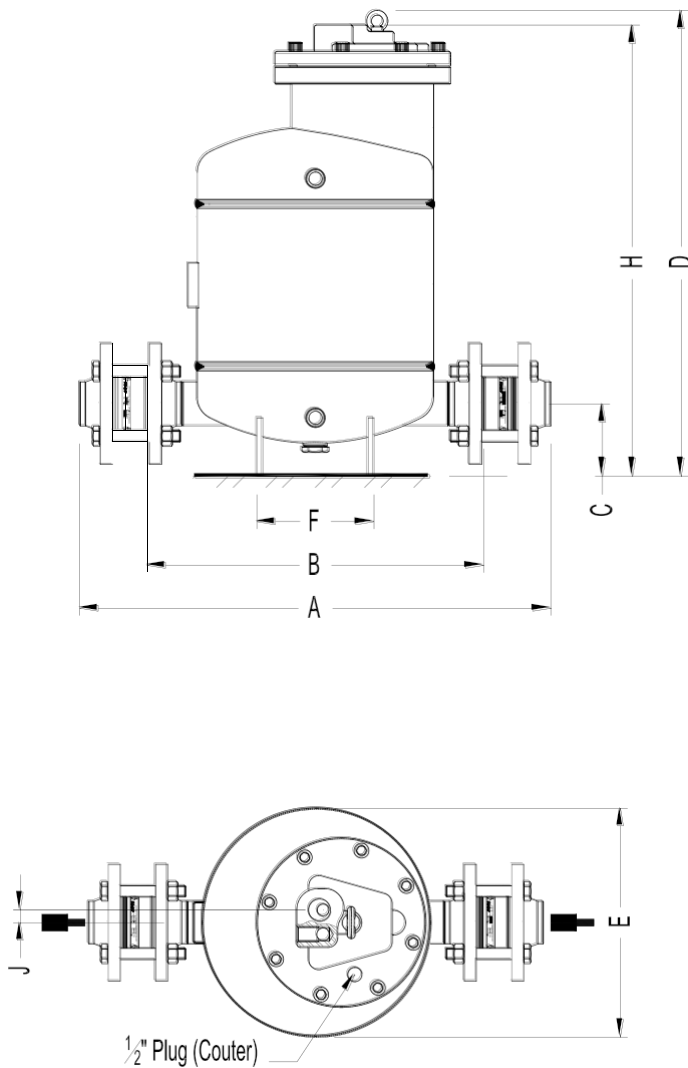

DIMENSIONS (mm)

DN	A *	B	C	D	E	F	G	H	I	J	L	M	Weight Kgs	VOL. dm3
25	578	444	100	640	323	160	250	617	598	17	18	327	71	31,7
40	615	454	100	640	323	160	250	617	598	17	18	327	72,8	31,8
50	644	460	100	640	323	160	250	617	598	17	18	327	74,5	31,9
80x50	776	580	113	650	406	200	340	627	608	17	18	307	78,5	48,9

* A - with welding neck EN 1092-1 flanges

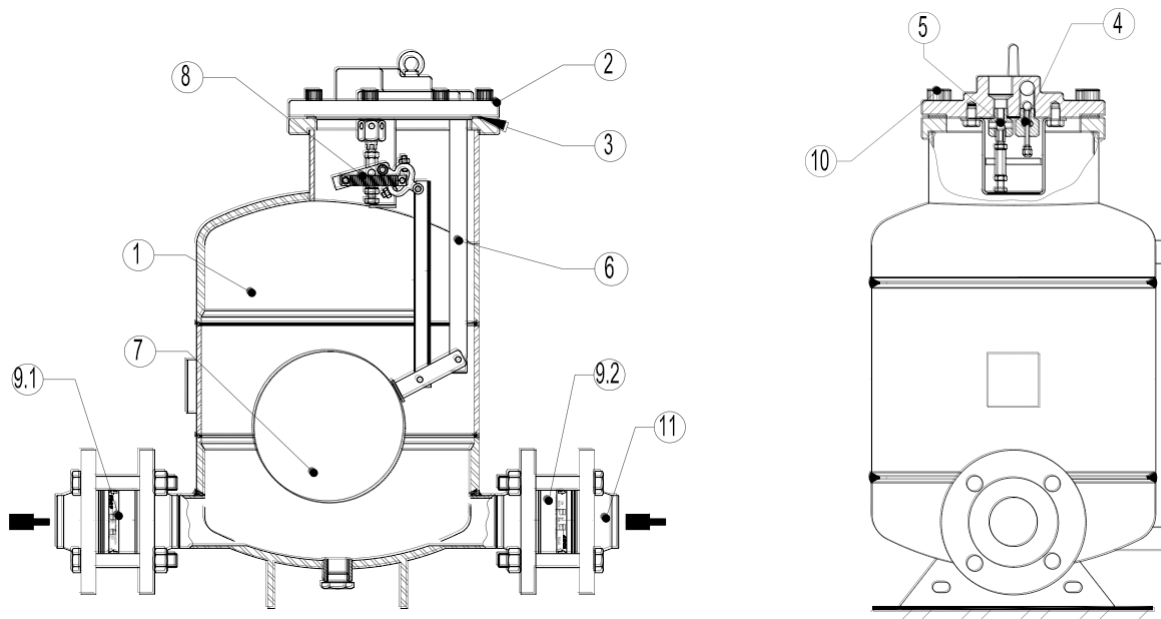

MATERIALS

POS.	DESIGNATION	MATERIAL - POP-S	MATERIAL - POP-SS
1	PUMP BODY	P265GH / 1.0425 ; P235GH / 1.0345 S235JR / 1.0038	AISI316 / 1.4401 ; AISI304 / 1.4301
2	COVER	GJS-400-15 / 0.7040 or ASTM A216WCB / 1.0619	AISI316 / 1.4401 ; AISI304 / 1.4301
3	*COVER GASKET	NON ASBESTOS	NON ASBESTOS
4	*INLETVALVE/SEAT ASSY.	STAINLESS STEEL	STAINLESS STEEL
5	*EXHAUST VALVE/SEAT ASSY.	STAINLESS STEEL	STAINLESS STEEL
6	INTERNAL MECHANISM	STAINLESS STEEL	STAINLESS STEEL
7	*FLOAT	STAINLESS STEEL	STAINLESS STEEL
8	*SPRING ASSY.(2PCS)	INCONEL	INCONEL
9.1	*RD40 OUTLET CHECK VALVE	CF8M / 1.4408	CF8M / 1.4408
9.2	*RD40 INLET CHECK VALVE	CF8M / 1.4408	CF8M / 1.4408
10	BOLTS	STEEL 8.8	A2 - 70
11	**PN16 EN 1092-1 FLANGES	P250GH / 1.0460	AISI316 / 1.4401

* Available spare parts

** Welding neck EN 1092-1 flanges. Threaded flanges on request.

Stroke counter :

Available on request, it can be screwed directly into the top cover of the pump or above the pump through a 1/2" size pipe for easier reading (max.1m).

