

UNIDIRECTIONAL or BIDIRECTIONAL Wall Penstock

- Penstock for clean liquids or loaded with solids.
- Design of square or rectangular penstock.
- Possibility of unidirectional or bidirectional.
- Various seal materials available.
- Common design to install supported on walls with chemical or expansion anchors.

General applications:

- This wall penstock is designed to be installed in orifices in walls. The orifice can be rectangular, round or square, this penstock has a 4-side seal.

This is suitable to work with clean liquids or loaded with solids. Used mainly in:

- Water treatment plants
- Irrigation
- Hydroelectric power stations
- Conduits

Sizes:

- From 150 x 150 up to 3000 x 3000 (larger sizes on request). Check with CMO for the general dimensions of a specific wall penstock.

Working (ΔP):

- The maximum working pressure adapts to the needs of the customer in every project. These penstocks are designed to comply with working conditions in the place of installation.

Civil works:

- CMO standard MC wall penstocks are designed to be secured to the wall using chemical or expansion anchors. The boreholes necessary for attachment are made when assembling, using the body of the penstock as a guide.

Sealtightness.

- The sealtightness of the CA wall penstocks complies with that set out in regulation DIN 19569, class 5 of leaks.

Directives:

- Machinery Directive: **DIR 2006/42/EC (MACHINERY)**
- Pressure Equipment Directive: **DIR 97/23/EC (PED) ART.3, P.3**
- Potentially Explosive Atmospheres Directive (optional): **DIR 94/9/EC (ATEX) CAT.3 ZONE 2 and 22 GD**, for information on categories and zones please contact Tubi Valve Technical-Sales Department.

Quality dossier:

- The sealtightness of the seat area is measured with gauges.
- Material and testing certificates can be supplied on request.

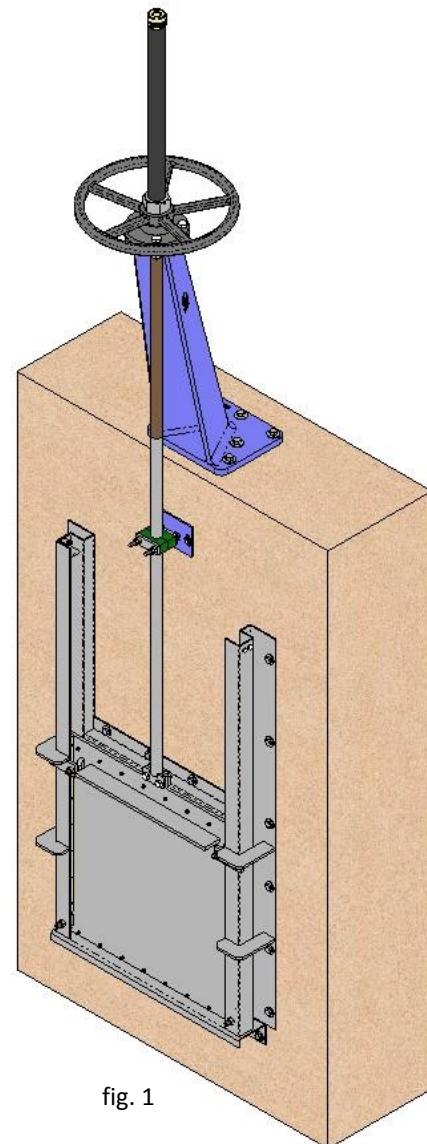

fig. 1

Advantages of CMO "MC Model"

The **MC** wall penstocks are designed to work with liquids. The main elements of the **MCs** are the body or frame, in which a through conduit or board which moves up and down and has a 4-side sealing system to prevent leakages of liquid is embedded. The stoppers are screwed onto the upper part of the body (only when manual actuator is fitted).

CMO standard **MCs** are designed for the body to be installed in the wall using chemical or expansion anchors. The interior dimensions of the body passage usually coincides with the dimensions of the wall orifice, thereby ensuring that there is no obstruction in the passage of the fluid, allowing entirely continuous passage whenever the penstock is completely open and avoiding any buildup of residue.

The stem protection hood is independent from the handwheel securing nut, this means the hood can be disassembled without the need to release the handwheel. This advantage allows regular maintenance operations to be performed, such as lubricating the stem, etc.

The stem on the CMO penstock is made of 18/8 stainless steel. This is another added advantage, as some manufacturers produce it with 13% chrome and it gets rusty very quickly.

The operating wheel is manufactured in nodular cast GGG50. Some manufacturers supply it in common cast-iron, which can lead to breakage in the event of very high operation torque or a bang.

The yoke is has a compact design with the bronze actuator nut protected in a sealed and lubricated box. This makes it possible to move the penstock with a key, even without the handwheel (in other manufacturers' products this is not possible).

The pneumatic actuator's upper and lower covers are made of GGG40 nodular cast iron, making them highly shock resistant. This characteristic is essential in pneumatic actuators.

The pneumatic cylinder's seals are commercial products and can be purchased worldwide. This means it is not necessary to contact CMO every time a seal is required.

COMPONENTS LIST			
COMPONENT	VERSION S275JR	VERSION AISI304	VERSION AISI316
1- Body	S275JR	AISI304	AISI316
2- Through conduit	S275JR	AISI304	AISI316
3- Seal	EPDM	EPDM	EPDM
4 - Flange	AISI304	AISI304	AISI316
5*- Guide	HD-500	HD-500	HD-500
6*- Wedge	A2	A2	A4
7*- Counterwedge	AISI316	AISI316	AISI316
8*- End stopper	S275JR	AISI304	AISI316
9- Countersunk screw	A2	A2	A4
10 - Washer	A2	A2	A4
11- Self-locking nut	A2	A2	A4
12*- Screw	5.6 ZINC	A2	A4
13* - Washer	5.6 ZINC	A2	A4
14*- Nut	5.6 ZINC	A2	A4

Note: The elements with * are optional.

table 1

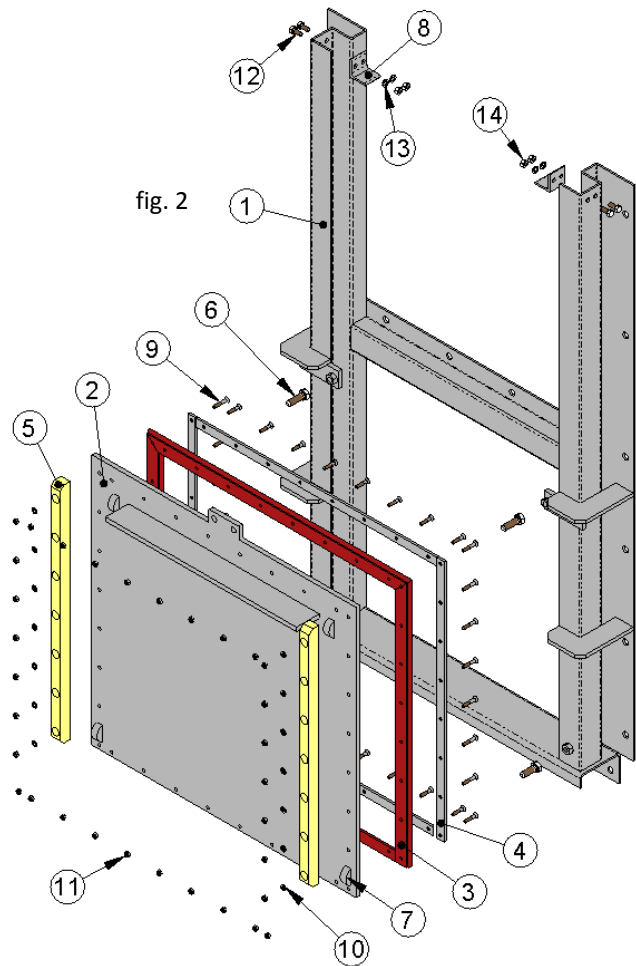

DESIGN CHARACTERISTICS
1- BODY

The body or frame is mechanically welded, manufactured in one single piece. Constructed with foldable profiles to prevent any deformation and to increase robustness. The side profiles have a gap throughout the length (in order to slide the through conduit), obtained by way of several folds (without welding), thus ensuring the body does not have any leakage.

The body has at least an approximate height of twice the through conduit, in order to house it when the penstock is completely open. The upper part is fitted with end stoppers (when manual actuator is fitted) in order to delimit the longitudinal movement of the through conduit.

The standard body is designed to be mounted supported on the wall using chemical or expansion anchors, meaning no type of housing is required in the civil work. As the body is designed in line with the dimensions of the wall orifice, there are no protrusions and passage is entirely continuous. When the wall orifice is at ground level, the penstock can be mounted with the base embedded in the concrete (fig. 33) or screwed down using chemical or expansion anchors (fig. 32), in which case it must be remembered that the channel passage is slightly narrower.

The bodies can be square or rectangular.

The material used is usually stainless steel AISI304 or AISI316, although carbon steel S275JR can also be used. In accordance with the conditions the penstock will be subject to, there are other special materials available to order, such as AISI316Ti, Duplex, 254SMO, Uranus B6, Aluminium, etc. As a rule, iron or carbon steel penstocks are painted with an anti-corrosive protection of 80 microns of EPOXY (colour RAL 5015), although other types of anti-corrosive protections are also available.

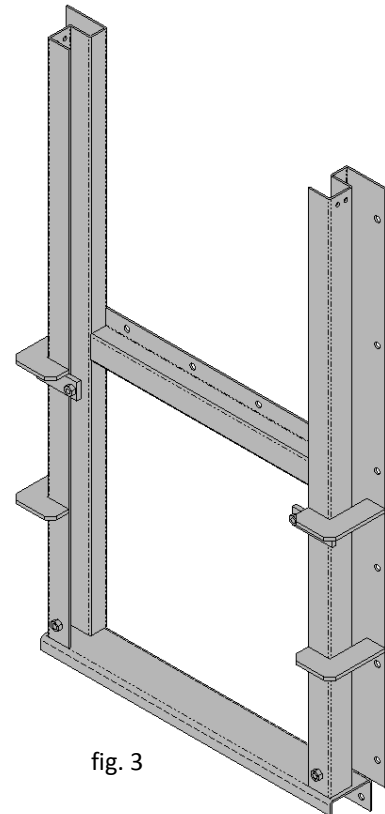

fig. 3

2- THROUGH CONDUIT

fig. 4

The through conduit manufacture material is usually the same as that used for the body, although it can also be supplied to order with other materials or combinations.

Depending on the dimensions of the penstock, some reinforcements are often welded on to the through conduit (as shown in fig. 4) in order to achieve the necessary rigidity. The stem is connected to the upper part of the through conduit, with its longitudinal movement making the penstock open or close. The four-side seal is secured to the through conduit with stainless steel flanges.

3- SEAT

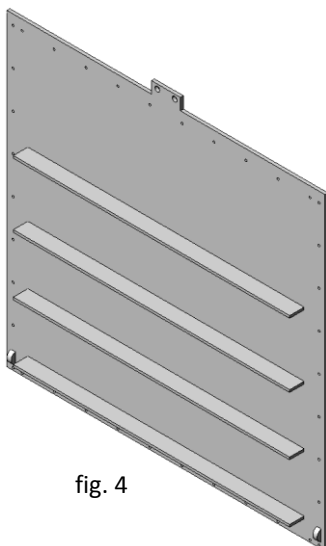
The standard seal in this type of penstocks comprises four rubber rims on the four different sides; these rubber rims are secured to the through conduit using stainless steel flanges. The sealtightness complies with that set out in regulation DIN 19569, class 5 of leaks.

Depending on the work application, the following options can be chosen from:

- FAVOURABLE UNIDIRECTIONAL: (fig. 5 and fig. 6)

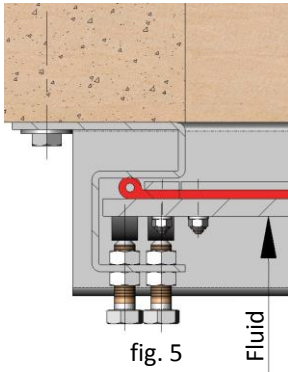

This type of penstock is used when the fluid direction pressures the penstock against the wall. The seals used in this type of penstocks are of musical note type.

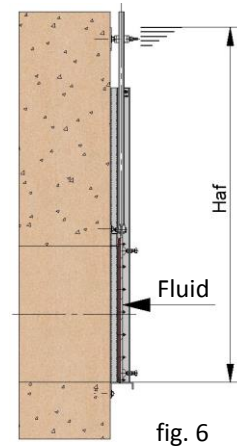

- UNFAVOURABLE UNIDIRECTIONAL: (fig. 7 and fig. 8)

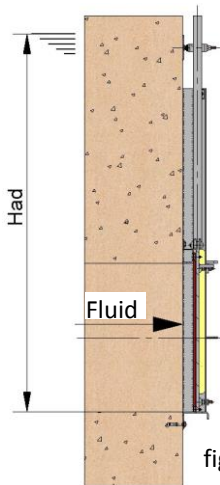

This type of penstock is used when the fluid direction always tends to separate the penstock from the wall. In this case the design of the penstock is identical to bidirectional. The seals used in this type of penstocks have two peaks.

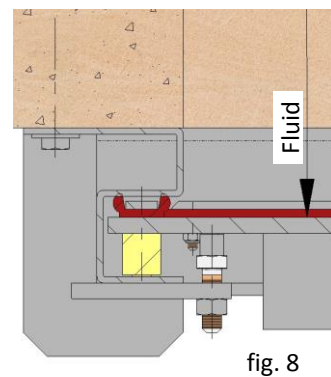

- BIDIRECTIONAL: (fig. 9 and fig. 10)

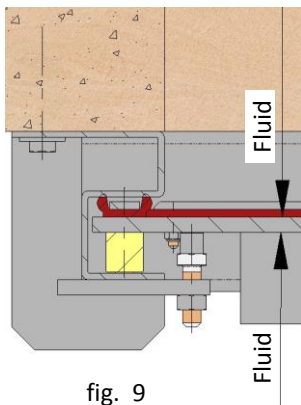

This type of penstock is used when the fluid can come from one direction or another, in other words the fluid may tend to separate the penstock from the wall or pressure against the wall. In this case the design of the penstock is identical to unfavourable unidirectional. The seals used in this type of penstocks have two peaks.

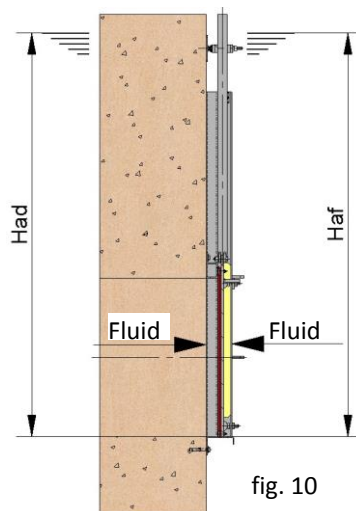

Although the standard sealtight joint is EPDM, there are other types of materials in order to choose the most suitable, in accordance with the work applications for the penstock (work temperature, fluid type, etc). Described here are the characteristics of the most common, which are summarised below in Table2:

Sealtight materials

EPDM

Recommended for temperatures no higher than 90°C*, it provides the penstock with 100% watertight integrity. Application: Water and acids.

NITRILE

It is used in fluids containing fats or oils at temperatures no higher than 90°C*. It provides the penstock with 100% watertight integrity.

VITON

Suitable for corrosive applications and high temperatures up to 190°C continuously and peaks of 210°C. It provides the penstock with 100% watertight integrity.

SILICONE

Mainly used in the food industry and for pharmaceutical products with temperatures no higher than 200°C. It provides the penstock with 100% watertight integrity.

PTFE

Suitable for corrosive applications and pH between 2 and 12. Does not provide the penstock with 100% watertight integrity. Estimated leakage: 0.5% of the flow.

NATURAL RUBBER

It can be used in multiple applications at temperatures no higher than 90°C with abrasive products and it provides the penstock with 100% watertight integrity. Application: fluids in general.

 **Note:** In some applications other types of resilient materials are used, such as hypalon, butile, etc. . Please contact us if you require one of these materials.

SEAT/SEALS		
Material	Max. T. (°C)	Applications
EPDM (E)	90 *	Non-mineral oils, acids and water.
Nitrile (N)	90 *	Hydrocarbons, oils and greases
Viton (V)	200	Hydrocarbons and solvents
Silicone (S)	200	Food Products
PTFE (T)	250	Resistant to corrosion
Natural Rubber	90	Abrasive products

table 2



Note: More details and other materials available to order.

* → EPDM and nitrile: is possible until serving temperature Max.: 120°C under request.

4- STEM

The stem on the CMO penstocks is made of 18/8 stainless steel. This characteristic provides high resistance and excellent corrosion-resistant properties.

The penstock design can be rising stem or non-rising stem. When a rising stem is required for the penstock, a stem hood is supplied to protect the stem from contact with dust and dirt, besides keeping it lubricated.

5- ACTUATORS

In these **MC** wall penstocks, when the height of the penstock is minimum, a yoke can be used in the upper part of the body to house the actuator (fig. 11). The same yoke will delimit the longitudinal movement of the through conduit.

To the contrary, when positioning the actuator at considerable distance from the location of the penstock, an extension can be coupled to the stem or rod and secure the actuator in a floor stand (fig. 12) or square bracket (fig. 13). In this case the body will have a stopper system to delimit the longitudinal movement of the through conduit (only in the case of manual actuators).

When starting up the actuator, it exercises the torque or draw necessary in the stem or rod, which in turn is transmitted to the through conduit to start movement.

Our wall penstocks are supplied with several types of actuator, bringing the advantage that, thanks to the design of CMO, they can be interchanged.

This design allows customers to change the actuators themselves and no extra assembly accessories are required.

The total dimensions of the penstock may vary in accordance with the type of actuator chosen.

Manual:

- Handwheel with rising stem
- Handwheel with non-rising stem
- Chainwheel
- Gears
- Others (square nut,...)

Automatic:

- Electric actuator
- Pneumatic cylinder
- Hydraulic cylinder

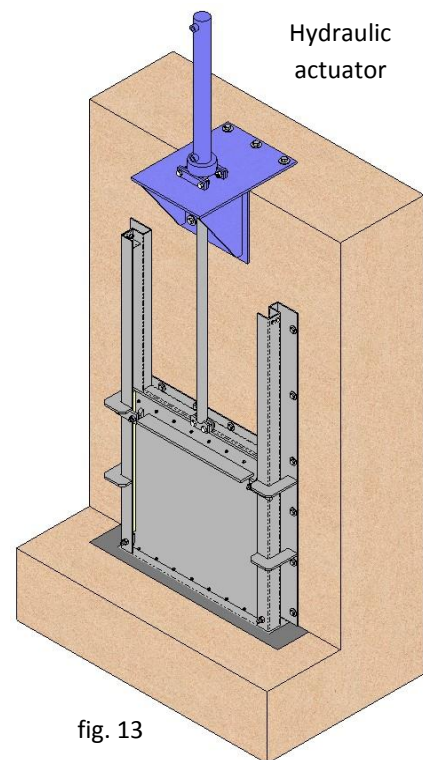
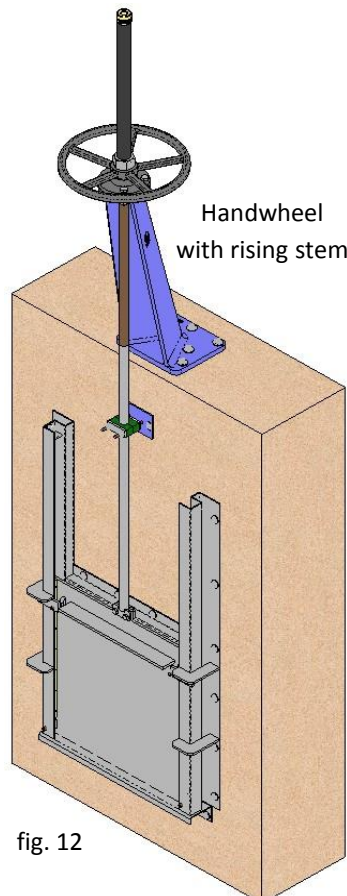
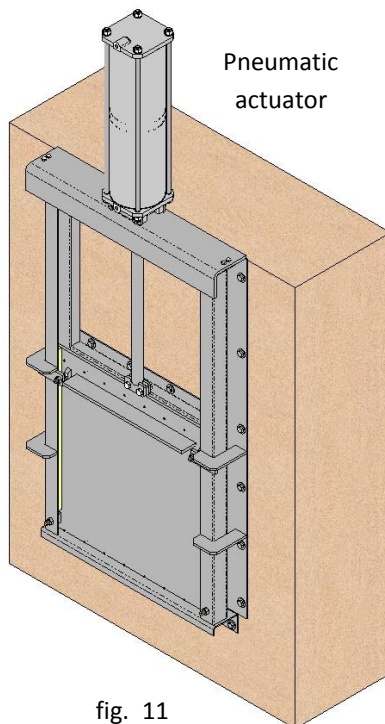

WALL PENSTOCK

MC SERIES

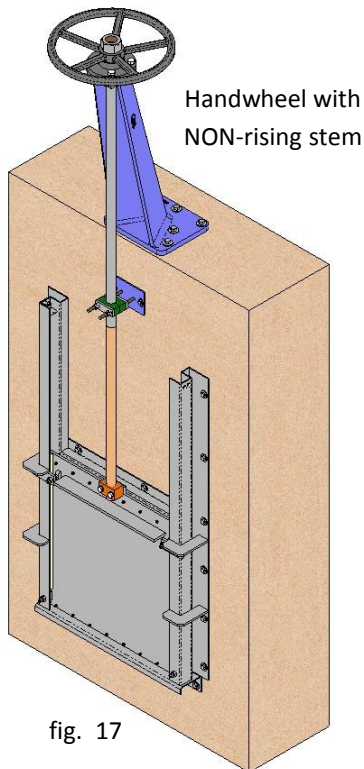
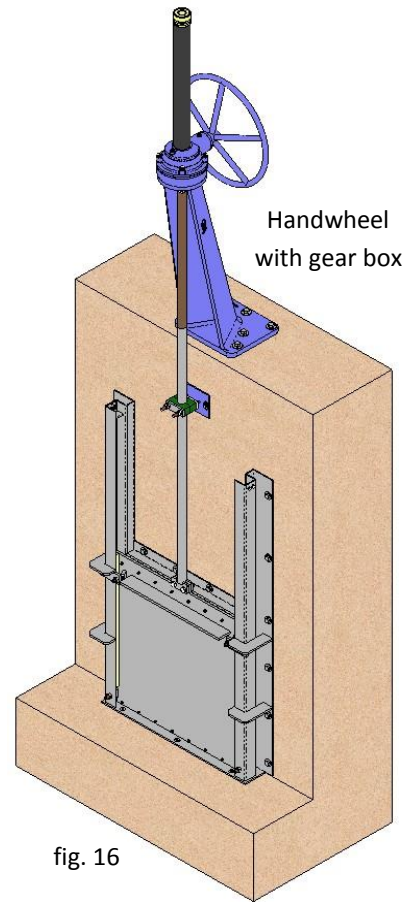
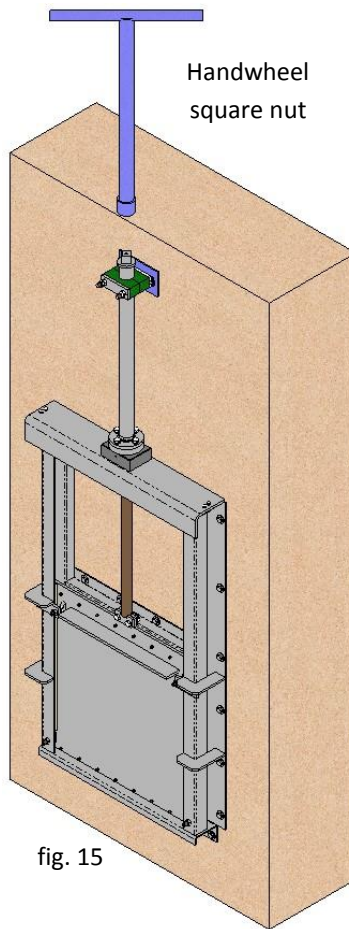
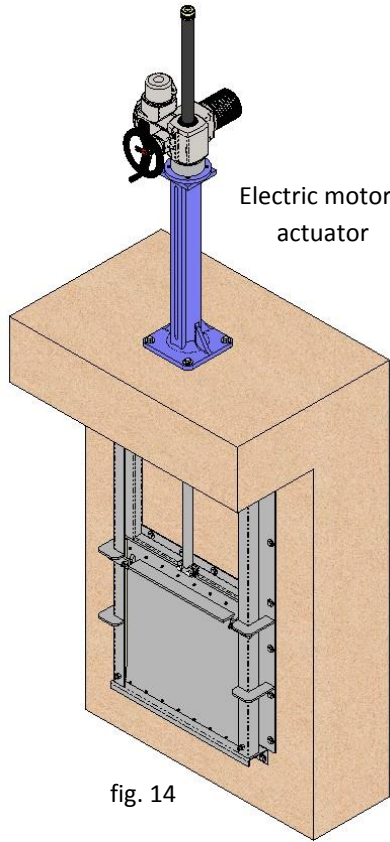

The handwheel, chainwheel, gear box and motor actuators are also available with non-rising stem.

WALL PENSTOCK

MC SERIES

Stem extensions have also been developed, allowing the actuator to be located far away from the penstock, to suit all needs. Please consult our technicians beforehand.

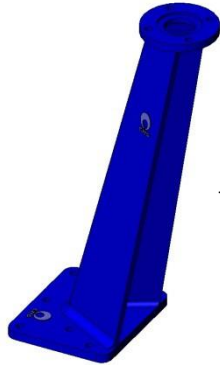

fig. 18

Wide range of accessories available:

- Mechanical stoppers
- Locking devices
- Emergency manual actuators
- Electrovalves
- Positioners
- Limit switches
- Proximity switches
- Straight floor stands (fig. 19)
- Leaning floor stand (Fig. 18)
- ...

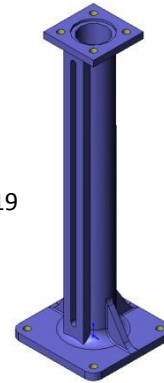

fig. 19

ACCESSORIES AND OPTIONS

Different accessories are available to adapt the penstock to specific working conditions such as:

- Mechanical limit switches, inductive switches and positioners (fig. 20):

Limit switches or inductive switches are installed to indicate precise penstock position, as well as positioners to indicate continuous position.

- Electrovalves (fig. 20):

For air distribution to pneumatic actuators.

- Connection boxes, wiring and pneumatic piping:

Units supplied fully assembled with all the necessary accessories.

- Stroke limiting mechanical stops:

Allow the stroke to be mechanically adjusted, limiting the penstock run.

- Mechanical locking device:

Allows the penstock to be mechanically locked in a set position for long periods.

- Emergency manual actuator (hand wheel / gear box):

Allows manual operation of the penstock in the event of power or air failure (fig. 20).

- Interchangeable actuators:

All actuators are easily interchangeable.

- Epoxy coating:

All carbon steel components and bodies of CMO penstocks are EPOXY coated, giving them great resistance to corrosion and an excellent surface finish. CMO's standard colour is blue RAL-5015.

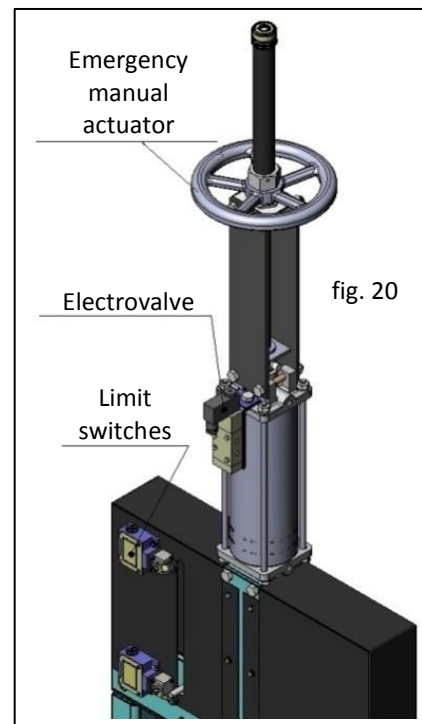

TYPES OF EXTENSION

When the penstock needs to be operated from a distance, the following different types of actuators can be fitted:

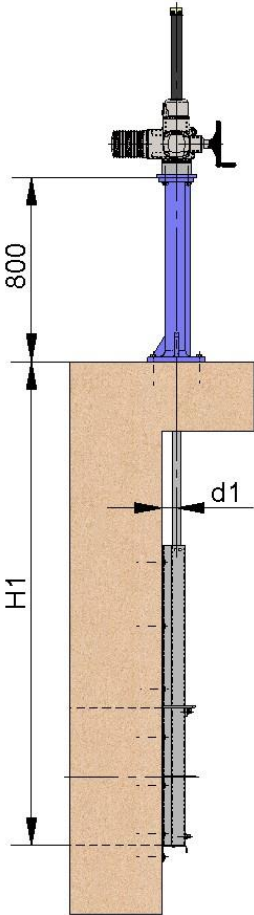

fig. 21

1 - Extension: Floor Stand.

This extension is performed by coupling a spindle to the elongation. By defining the length of the elongation, the desired extension is achieved. A floor stand is normally installed to support the actuator.

The definition variables are as follows:

H1: Distance from the base of the wall orifice to the base of the floor stand.

d1: Separation from the wall to the extension shaft.

Characteristics:

- It can be coupled to any type of actuator.
 - A stem support-guide is recommended (fig. 22) every 1.5 m.
 - The standard floor stand is 800 mm high (fig. 21).
- Other floor stand measurements available to order.
- A position indicator can be fitted to determine the degree of opening of the penstock.
 - Possibility of leaning floor stand (fig. 23).

fig. 22

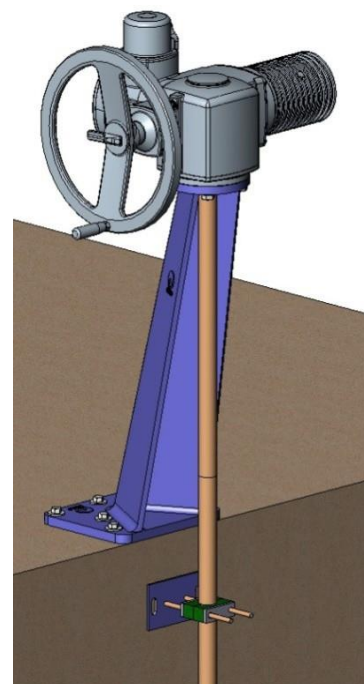
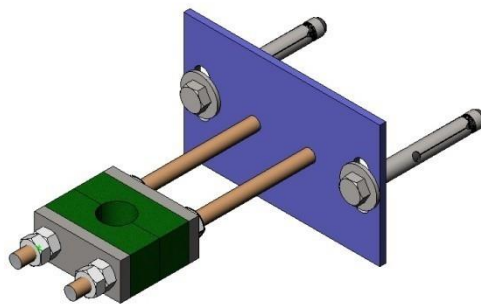

fig. 23

COMPONENTS LIST

Component	Standard Version
Stem	AISI 303
Stem	AISI 304
Guide-support	Carbon steel with EPOXI coating
Slide	Nylon
Floor Stand	GGG 50 with EPOXY coating

table 3

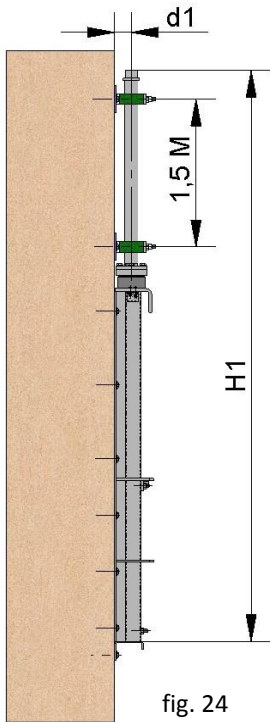

fig. 24

2 - Extension: Pipe (fig. 24)

Consists of raising the actuator. The pipe will rotate with the wheel or key when the penstock is operated, although this will always remain at the same height.

The definition variables are as follows:

H1: Distance from the base of the wall orifice to the required height of the actuator.

d1: Separation from the wall to the pipe shaft.

Characteristics:

- Standard actuators: Handwheel and "Square Nut".
- A pipe support-guide is recommended every 1.5m.
- The standard materials are: EPOXY coated carbon steel or stainless steel.

3 - Extension: Extended body guides (fig. 25)

When an extension is required, it can be achieved by extending the guides of the body. An intermediate yoke can be fitted to reinforce the body guides structure.

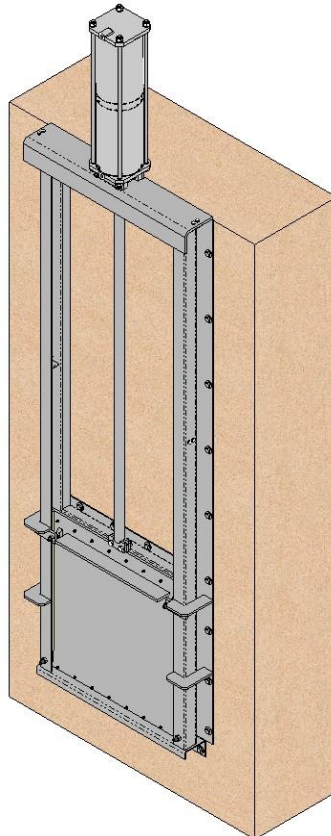

fig. 25

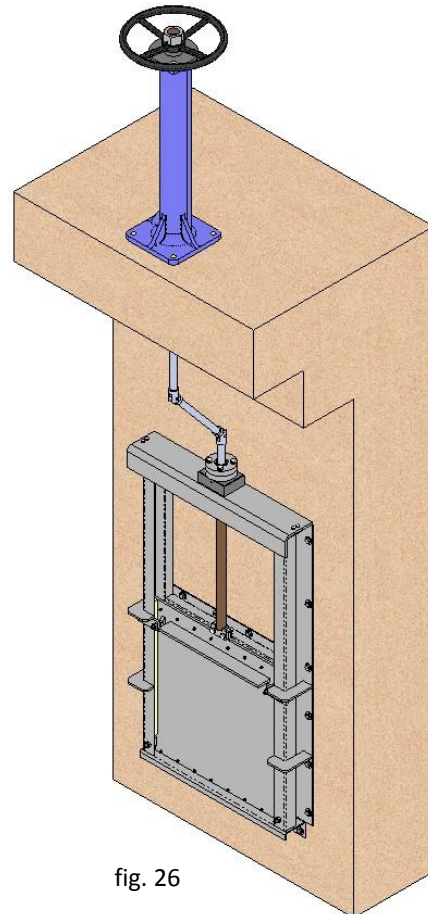

fig. 26

4 - Extension: Cardan joint (fig. 26)

If the penstock and the actuator are not in correct alignment, the problem can be resolved by fitting a universal joint.

GENERAL DIMENSIONS

In order to define an **MC** wall penstock, we need to know the width and height of the penstock, the fluid direction and the fluid load on each side of the penstock. We also need to know the height from the floor (H_s).

The levels **A** and **B** will be used to refer to the width and height variables, whilst the designation mode will be $A \times B$ (Width x Height). The dimensions range from 150 x 150 up to 3000 x 3000 (larger dimensions upon request). These penstocks may be square or rectangular, meaning they do not need to have the same width (**A**) and height (**B**). Each level is described in fig. 27:

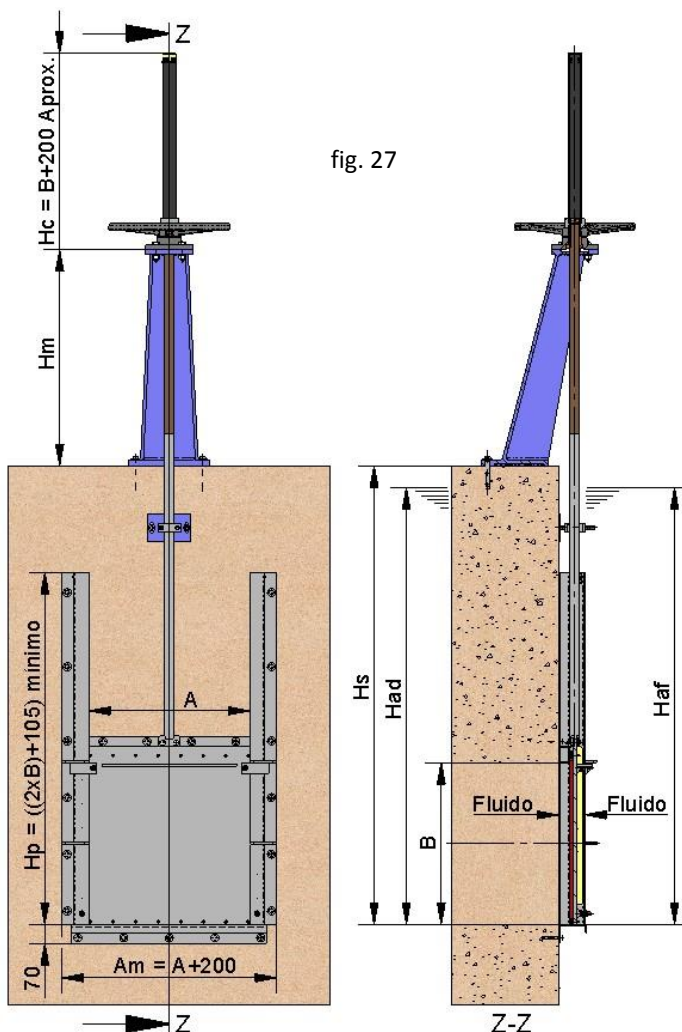

fig. 27

- **Level A:** This is used to define the width of the penstock.

- **Level B:** This is used to define the height of the penstock.

- **Level Hs:** This is used to define the height from the orifice base to the floor.

- **Level Hm:** This is used to define the distance from the floor to where the actuator is located. This level (H_m) is usually 800 mm, allowing a person to comfortably handle the penstock.

- **Level Hp:** This is used to define the distance from the base of the penstock through to the upper part of the body. This level must be at least twice the height of the penstock (B) plus 105 mm (in order for the penstock to open completely).

- **Level Hc:** This is used to define the total height of the actuator. This level (H_c) is usually the height of the penstock (B) plus 200 mm.

If the penstock has a non-rising stem actuator, the H_c level is reduced, and will have an approximate value of 300 mm (depending on the actuator installed).

- **Level Am:** This is used to define the maximum width covered by the body. This level (A_m) is usually the width of the penstock (A) plus 200 mm.

- **Level Haf:** This is used to define the

unfavourable fluid load (when the fluid direction pressures the penstock against the wall), the H_{af} level defines the maximum fluid level measured from the base of the orifice.

- **Level Had:** This is used to define the unfavourable fluid load (when the fluid direction tends to separate the penstock from the wall), the H_{ad} level defines the maximum fluid level measured from the base of the orifice.

WALL PENSTOCK

MC SERIES

When the wall orifice is at ground level, the penstock cannot be mounted in the usual manner (the entire penstock supported on the wall using chemical or expansion anchors). For this reason there are two variants of the standard version, which in these cases allow the penstocks to be satisfactorily installed.

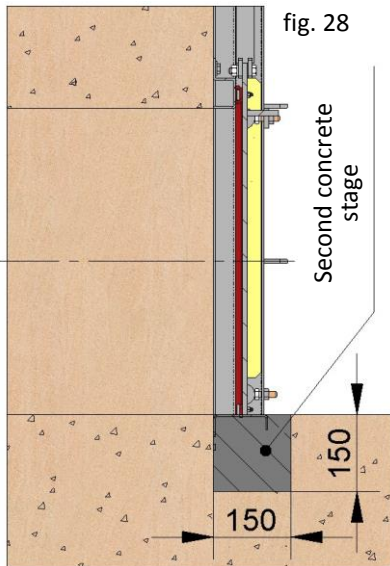

SIDE VIEW

The penstock can be mounted with the base embedded in the concrete. To mount it in this way, it is necessary to make housing in the base in order to introduce the penstock and carry out subsequent concreting. The dimensions necessary for this housing are shown in fig. 28 and fig. 29:

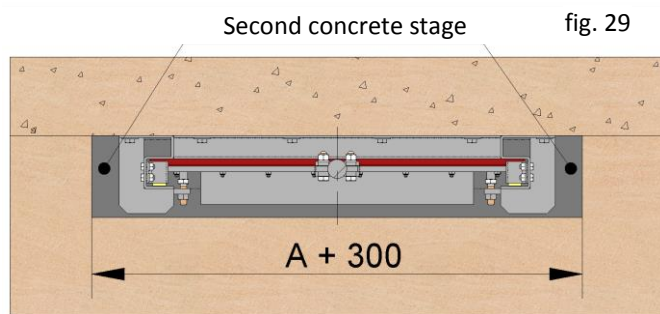

PLAN VIEW

When the civil work is constructed and does not have the housing necessary to mount with the base already concreted, the penstock can be constructed with a flat base and secured with chemical or expansion anchors (fig. 30).

In this case a flat rim will be secured to the base of the civil work, where the penstock can make the lower seal. The thickness of this rim (level E) varies in accordance with the width of the penstock (A), as defined in table 4.

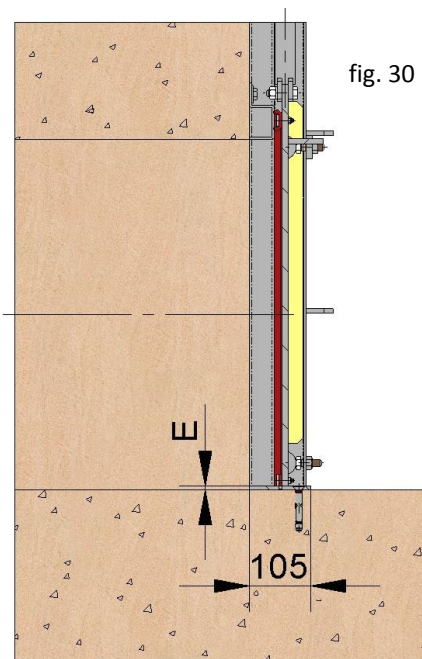

SIDE VIEW

LOWER RIM (BASE)	
Penstock width (A)	Base rim thickness (E)
150 ~ 1000 mm	6 mm
1100 ~ 2000 mm	8 mm
2000 ~ 3000 mm	10 mm

table 4

FASTENING OPTIONS

As described above, the most common system to mount these wall penstocks is by supporting them on the wall and securing with chemical or expansion anchors (fig. 31), although, as can be seen in fig. 32 and fig. 33, there are other assembly options.

Whatever the fastening option, the upper and side profiles are always secured with chemical or expansion anchors. For this reason, it is very important that the wall is completely flat, otherwise the body may become deformed and produce irreparable damage when tightening the anchoring.

It is therefore recommended to use a flat rule when screwing down the body. Support the rule on the body and begin to tighten the anchor screws, and stop tightening as soon as the body begins to deform.

- In order to mount the penstock using chemical or expansion anchors (the most common way), place the penstock completely open on the wall, ensuring the passage of the penstock coincides with the orifice of the wall. Using the holes of the body of the penstock as a guide, make the boreholes in the wall for the chemical or expansion anchors. Remove the penstock and apply sealing paste such as SIKAFLEX-11FC or similar where the penstock is to be located, in order to prevent leakages between the body and the wall. Return the penstock to its location and screw down using the chemical or expansion anchors. Take care to screw crosswise, using a flat rule and without excessive force, in order to ensure the penstock does not become deformed.

This procedure can be used both for flat base (fig. 32) and standard penstocks (fig. 31).

-In order to mount the penstock with the base embedded in the concrete (fig. 33), the civil work must have housing in the ground with the dimensions previously defined in fig. 28 and fig. 29. Once the penstock is in position in the housing, align it with regards to the wall orifice, ensuring that the base of the penstock is level with the civil work, thus ensuring that there is no protrusion in the base and guaranteeing entirely continuous passage. Make the boreholes necessary for the upper and side profiles, using the holes of the body of the penstock as a guide. Remove the penstock and apply sealing paste such as SIKAFLEX-11FC or similar where the penstock is to be located on the wall, in order to prevent leakages between the body and the wall. Return the penstock to its location and screw down with chemical or expansion anchors using the usual procedure, namely with the help of a flat rule, screwing crosswise and without excessive force.

This is followed by the second stage of concreting, which involves filling in the housing of the base, ensuring there is no protrusion in the passage of the fluid.

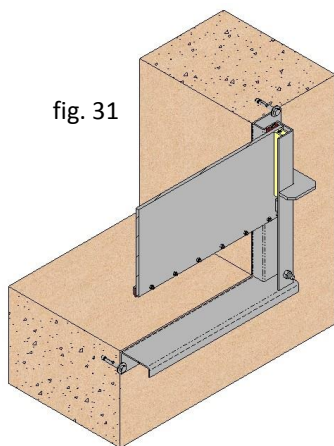

fig. 31
Secured to the wall using chemical or expansion anchors (standard)

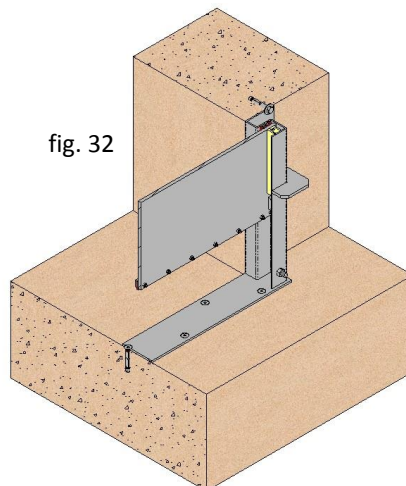

fig. 32
Flat base

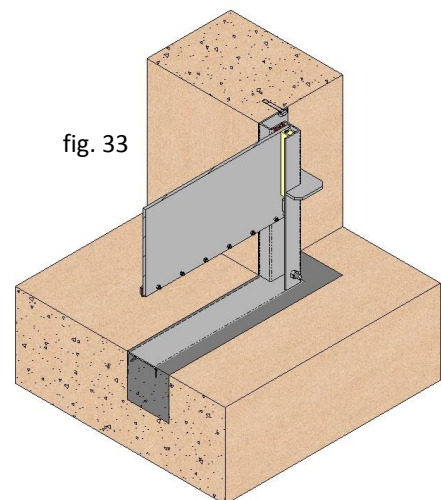

fig. 33
Base with housing