

UNIDIRECTIONAL Knife Gate Valve

- Unidirectional wafer-design knife gate valve.
- One-piece cast body with guides to support gate and seat wedges.
- Provides high flow rates with low pressure drop.
- Various seat and packing materials available.
- Face-to-face dimension in accordance with CMO standard.
- It has an arrow on the body indicating the flow direction.

General Applications:

- This knife gate valve is suitable for working with dry products like powder and grain. It is generally used for gravity discharge of dry solids. Designed for the following applications:
- Mining -Silo emptying - Electrical power stations
- -Chemical plants -Food Industry

Sizes: DN50 to DN1200 (larger sizes on request).

Working (ΔP):

DN50 to DN150	3 kg/cm ²
DN200 to DN300:	2 kg/cm ²
DN350 to DN400:	1.5 kg/cm ²
DN450 to DN1200	1 kg/cm ²

- This valve is usually mounted under a hopper, to prevent any kind of solids accumulating on the seat, the valve has a special body design and it is assembled with the body arrow in the same direction as the fluid.
- The design of the **F** valve seat is the same as for the **A** valve, but the pressures vary to those working the **F** valves.

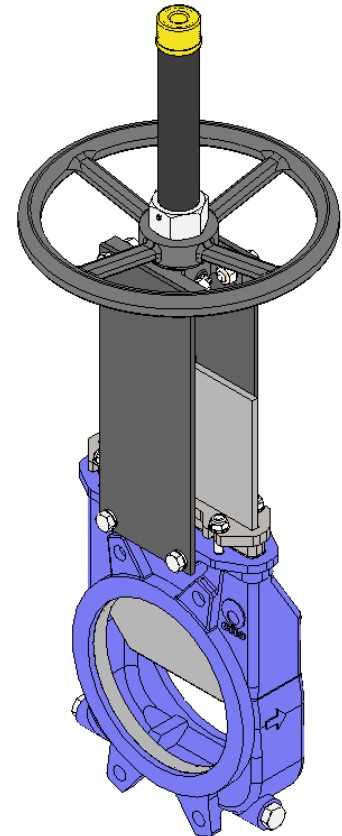

Fig. 1

Standard Flanges: DIN PN10 and ANSI B 16.5 (class 150)

Other Common Flanges: - ANSI 125 - DIN PN16 - DIN PN6 - DIN PN25 - BS "D" and "E"

- Others on request

Directives:

- Machinery Directive: **DIR 2006/42/EC (MACHINERY)**
- Pressure Equipment Directive: **DIR 97/23/EC (PED) ART.3, P.3**
- Potential Explosive Atmospheres Directive (optional): **DIR 94/9/EC (ATEX) CAT.3 ZONE 2 and 22 GD** for further information on categories and zones please contact the Tubi Valve Technical-Commercial Dept.

Quality Dossier:

- All valves are tested hydrostatically at CMO and material and test certificates can be provided.
- Body test = working pressure x 1.5
- Seat test = working pressure x 1.1

Advantages of CMO's "Model F"

When a knife gate valve remains open for long periods of time and the body's internal walls are parallel a very large torque is usually required to close it. However, the inside of the body of model F is cone-shaped, which provides greater space and, this way, when the valve is closed the solids stored inside it can be easily removed.

The F valve is unidirectional and an arrow is marked on the body indicating the flow direction.

The stem protection hood is independent from the handwheel securing nut, this means the hood can be disassembled without the need to release the handwheel. This advantage allows regular maintenance operations to be performed, such as lubricating the stem, etc.

The stem on the CMO valve is made of 18/8 stainless steel. This is another added advantage, as some manufacturers produce it with 13% chrome and it gets rusty very quickly.

The handwheel is made of GJS-500 nodular cast iron. Some manufacturers produce them in normal cast iron which can lead to breakages in the event of very high operating torque or knocks.

The yoke is has a compact design with the bronze actuator nut protected in a sealed and lubricated box. This makes it possible to move the valve with a key, even without the handwheel (in other manufacturers' products this is not possible).

The pneumatic actuator's upper and lower covers are made of GJS-400 nodular cast iron, making them highly shock resistant. This characteristic is essential in pneumatic actuators.

The pneumatic cylinder's o-ring seals are commercial products and can be purchased worldwide. This means it is not necessary to contact CMO every time a seal is required.

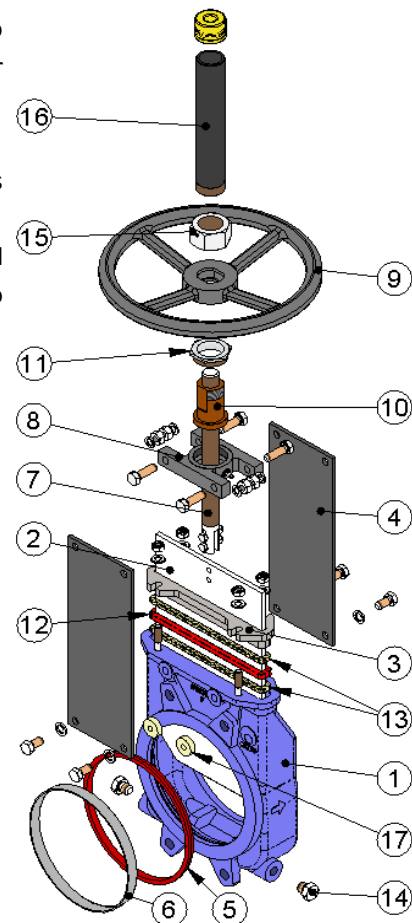

Fig. 2

STANDARD COMPONENTS LIST		
COMPONENT	CAST IRON VERSION	STAINLESS STEEL VERSION
1- Body	GJL-250	CF8M
2- Gate	AISI304	AISI316
3- Packing gland	GJS-450	CF8M
4- Support plates	S275JR	S275JR
5- O-ring seal	EPDM	EPDM
6- Ring	AISI316	AISI316
7- Stem	AISI303	AISI303
8- Yoke	ACERO	ACERO
9- Handwheel	GJS-500	GJS-500
10- Stem nut	BRONZE	BRONZE
11- Stop nut	F-111	F-111
12- Packing seal	EPDM	EPDM
13- Packing	SYNT + PTFE	SYNT + PTFE
14- Threaded cap (optional)	A-2	A-4
15- Nut	STEEL	STEEL
16- Hood	STEEL	STEEL
17- Guide	RCH1000	RCH1000

Table 1

DESIGN CHARACTERISTICS

1- BODY

Unidirectional wafer-design knife gate valve. One-piece cast body with guides to support gate and seat wedges.

For diameters greater than DN1200 the body is machine-welded with the necessary reinforcements to resist the maximum working pressure.

Full port designed to provide high flow rates with low pressure drop.

The body's internal design prevents any build up of solids in the seat area.

The standard manufacturing materials are GJL-250 cast iron and CF8M stainless steel. Other materials, such as GJS-500 nodular cast iron, A216WCB carbon steel and stainless steel alloys (AISI316Ti, Duplex, 254SMO, Uranus B6...) are available on request. As standard, iron or carbon steel valves are painted with an anti-corrosive protection of 80 microns of EPOXY (colour RAL 5015). Other types of anti-corrosive protections are available on request.

2- GATE

The standard manufacturing materials are AISI304 stainless steel in valves with iron body and AISI316 stainless steel in valves with CF8M body. Other materials or combinations can be supplied on request.

The gate is polished on both sides to provide a smooth contact surface with the resilient seat. At the same time, the gate is rounded to prevent the seat from being cut. Different degrees of polishing, anti-abrasion treatments and modifications are available to adapt the valves to the customer's requirements.

3- SEAT: (watertight)

Six types of seats are available according to the working application:

- **Seat 1:** Metal / metal seat. This type of seat does not include any kind of resilient seat and the estimated leakage (considering water as the test fluid) is 1.5% of the pipe flow.
- **Seat 2:** Standard soft-seated valve. This type of seat includes a resilient seat which is fixed to the inside of the body via an AISI316 stainless steel retaining ring.
- **Seat 3:** Soft-seated valve with reinforced socket. This type of seat includes a resilient seat which is fixed to the inside of the body via a reinforced retaining ring with two functions (to protect the valve from abrasion and clean the gate when working with solids that can stick to it).

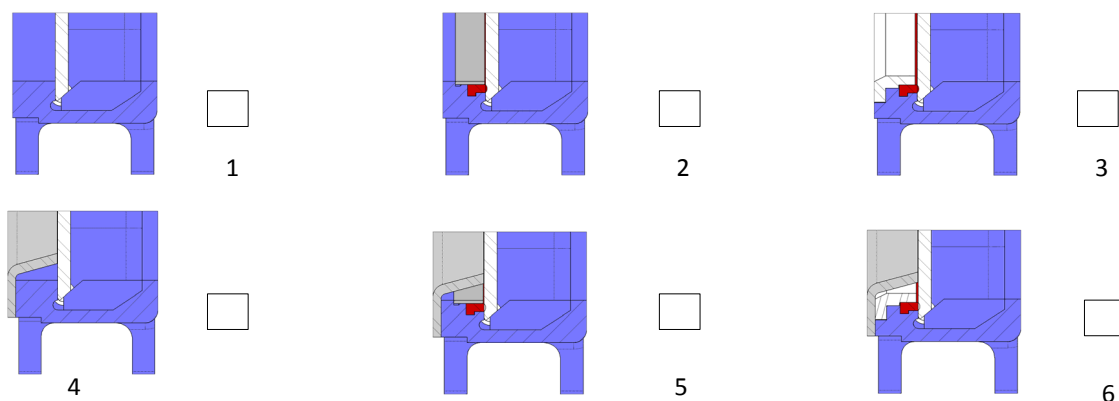

Fig. 3

- **Seats 4, 5 and 6:** The same as seats 1, 2 and 3 but including a deflector. The deflector is a cone-shaped ring located at the valve's entrance with two functions (to protect the valve from abrasion and guide the flow to the centre of the valve).

***Note:** Three materials are available for the reinforced socket and the deflector: Steel CA-15, CF8M and Ni-hard.

Resilient seat materials

EPDM

This is the standard resilient seat fitted on CMO valves. It can be used in many applications, however, it is generally used for water and products diluted in water at temperatures no higher than 90°C*. It can also be used with abrasive products and it provides the valve with 100% watertight integrity.

NITRILE

It is used in fluids containing fats or oils at temperatures no higher than 90°C*. It provides the valve with 100% watertight integrity.

VITON

Suitable for corrosive applications and continuous high temperatures of up to 190°C and peaks of 210°C. It provides the valve with 100% watertight integrity.

SILICONE

Mainly used in the food industry and for pharmaceutical products with temperatures no higher than 200°C. It provides the valve with 100% watertight integrity.

PTFE

Suitable for corrosive applications and pH between 2 and 12. Does not provide the valve with 100% watertight integrity. Estimated leakage: 0.5% of the tube flow.

 **Note:** In some applications other types of resilient materials are used, such as hypalon, butile or natural rubber. Please contact us if you require one of these materials.

4- PACKING

CMO's standard packing is composed of three lines with a specially designed EPDM O-ring in the middle which provides watertight integrity between the body and the gate, preventing any type of leakage to the atmosphere. It is located in an easily accessible place and can be replaced without dismantling the valve from the pipeline. Below we indicate various types of packing available according to the application to be given to the valve:

GREASED COTTON (Recommended for hydraulic services)

This packing is composed of braided cotton fibres soaked in grease both inside and out. It is for general use in hydraulic applications in both pumps and valves.

DRY COTTON

This packing is composed of cotton fibres. It is for general use in hydraulic applications with solids.

COTTON + PTFE

This packing is composed of braided cotton fibres soaked in PTFE both inside and out. It is for general use in hydraulic applications in both pumps and valves.

KNIFE-GATE VALVES

F SERIES

SYNTHETIC + PTFE

This packing is composed of braided synthetic fibres soaked in PTFE both inside and out. It is for general use in hydraulic applications in both pumps and valves and in all types of fluids, especially corrosive ones, including concentrated and oxidising oils. It is also used in liquids with solid particles in suspension.

GRAPHITE

This packing is composed of high-purity graphite fibres. A diagonal braiding system is used and it is impregnated with graphite and lubricant which helps to reduce porosity and improve operation.

It has a wide range of applications as graphite is resistant to steam, water, oils, solvents, alkali and most acids.

CERAMIC FIBRE

This packing is composed of ceramic material fibres. Its main applications are with air or gas at high temperatures and low pressures.

SEAT/SEALS			PACKING			
Material	Max. T. (°C)	Applications	Material	P(bar)	Max. T. (°C)	pH
Metal/Metal	>250	High T./Low watertight integ.	Greased cotton	10	100	6-8
EPDM (E)	90 *	Mineral acids and oils	Dry cotton (DC)	0.5	100	6-8
Nitrile (N)	90 *	Hydrocarbons, oils and greases	Cotton + PTFE	30	120	6-8
Viton (V)	200	Hydrocarbons and solvents	Synthetic + PTFE	100	-200+270	0-14
Silicone (S)	200	Food products	Graphite	40	650	0-14
PTFE (T)	250	Corrosion resistant	Ceramic Fibre	0,3	1400	0-14

NOTE: More details and other materials available on request.

* → EPDM and nitrile: is possible until serving temperature Max.: 120°C under request.

Table 2

5- STEM

The stem on the CMO valve is made of 18/8 stainless steel. This characteristic provides high resistance and excellent corrosion-resistant properties.

The valve design can be rising stem or non-rising stem. When a rising stem is required for the valve a stem hood is supplied to protect the stem from contact with dust and dirt, besides keeping it lubricated.

6- PACKING GLAND

The packing gland allows uniform force and pressure to be applied to the packing to ensure watertight integrity.

As standard, valves with cast iron body include GJS-450 packing glands, whilst valves with stainless steel body have CF8M packing glands.

7- ACTUATORS

All types of actuators can be supplied, with the advantage that thanks to the CMO design they are fully interchangeable. This design allows the customer to change the actuators themselves and no extra assembly accessories are required. A design characteristic of CMO S.L. valves is that all actuators are interchangeable.

Manual:

- Handwheel with rising stem
- Handwheel with non-rising stem
- Chainwheel
- Lever
- Gear Box
- Others (square nut,...)

Automatic:

- Electric actuator
- Pneumatic cylinder
- Hydraulic cylinder

KNIFE-GATE VALVES

F SERIES

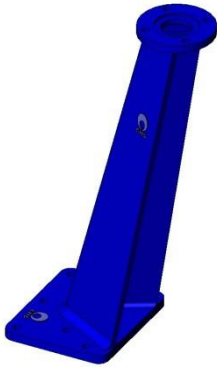

Fig. 4

Wide Range of Accessories Available:

- Mechanical stops
- Locking devices
- Emergency manual actuators
- Solenoid valves
- Positioners Limit switches
- Proximity switches
- Straight floor stands (Fig. 5)
- Leaning floor stand (Fig. 4)

...

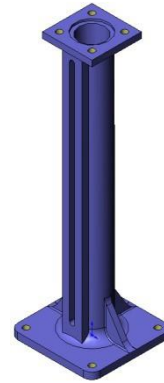

Fig. 5

Stem extensions have also been developed, allowing the actuator to be located far away from the valve, to suit all needs. Please consult our technicians beforehand.

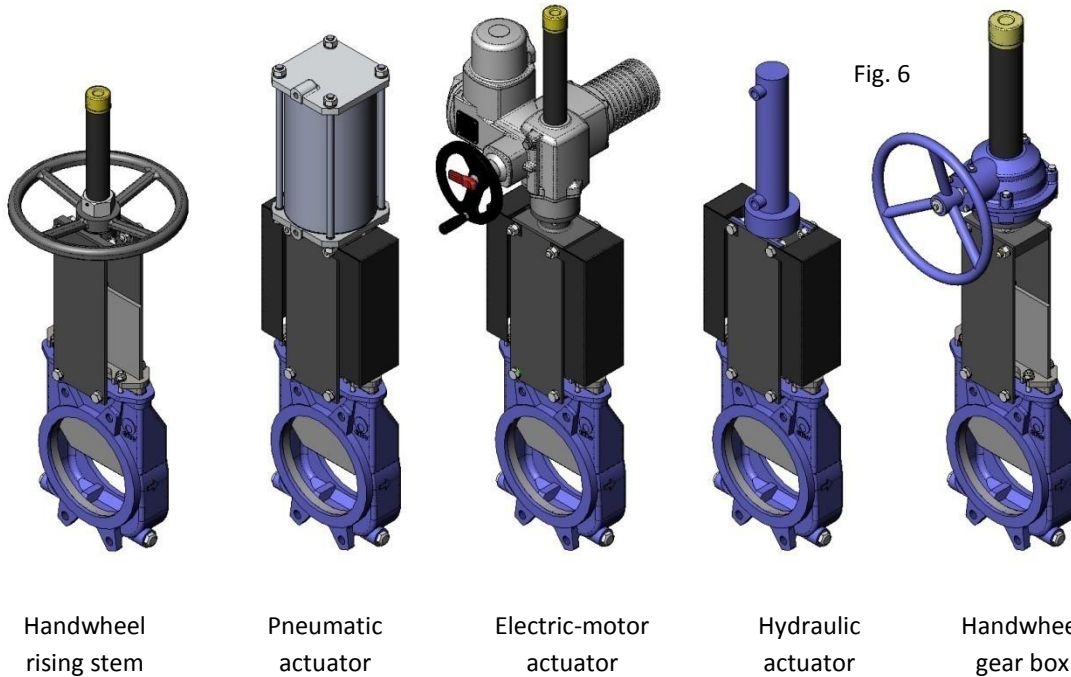

Fig. 6

Handwheel
rising stem

Pneumatic
actuator

Electric-motor
actuator

Hydraulic
actuator

Handwheel
gear box

ACCESSORIES AND OPTIONS

Different accessories are available to adapt the valve to specific working conditions such as:

Mirror Polished Gate:

The mirror polished gate is especially recommended in the food industry and, as standard, in applications in which solids can stick to the gate. It is an alternative to ensure the solids slide off and do not stick to the gate.

PTFE Lined Gate:

As with the mirror polished gate, it improves the valve's resistance to products that can stick to the gate.

Stellited Gate:

Stellite is added to the gate's internal circle to protect it from abrasion.

Scraper in the Packing:

Its function is to clean the gate during the opening movement and prevent possible damage to the packing.

Air Injections in the Packing Gland:

By injecting air in the packing, an air chamber is created which improves the watertight integrity.

Heating Jacket:

Recommended in applications in which the fluid can harden and solidify inside the valve's body. An external jacket keeps the body temperature constant, preventing the fluid from solidifying.

Flushing Holes in Body:

Several holes are drilled in the body to flush air, steam or other fluids out with the aim of cleaning the valve seat before sealing.

Mechanical Limit Switches, Inductive Switches and Positioners:

Limit switches or inductive switches are installed to indicate precise valve position, as well as positioners to indicate continuous position (Fig. 7).

Solenoid valves (Fig. 7)

For air distribution to pneumatic actuators.

Connection Boxes, Wiring and Pneumatic Piping

Units supplied fully assembled with all the necessary accessories.

Stroke Limiting Mechanical Stops:

They allow the stroke to be mechanically adjusted, limiting the valve's desired run.

Mechanical Locking Device:

Allows the valve to be mechanically locked in a set position for long periods.

Emergency Manual Actuator (Hand Wheel /Gear Box) (Fig. 7):

Allows manual operation of the valve in the event of power or air failure.

Triangular (V-Notch) and Pentagonal Diaphragm with Indication Rule:

Recommended for application in which it is necessary to regulate the flow, it allows flow control according to the valve's opening percentage.

Interchangeable actuators:

All actuators are easily interchangeable.

Actuator or Yoke Support

Made of EPOXY-coated steel (or stainless steel on request), its robust design gives it great rigidity in order to resist the most adverse operation conditions.

Epoxy Coating:

All cast iron and carbon steel bodies and components on CMO valves are EPOXY coated, giving the valves great resistance to corrosion and an excellent finish. CMO's standard colour is **blue** RAL-5015.

Gate Safety Protection:

In accordance with European Safety Standards ("EC" marking), CMO automated valves are equipped with gate guards, to prevent any objects from being accidentally caught in the gate.

Bonnet (mod. FK):

Provides total watertight integrity to the outside, reducing the packing maintenance required.

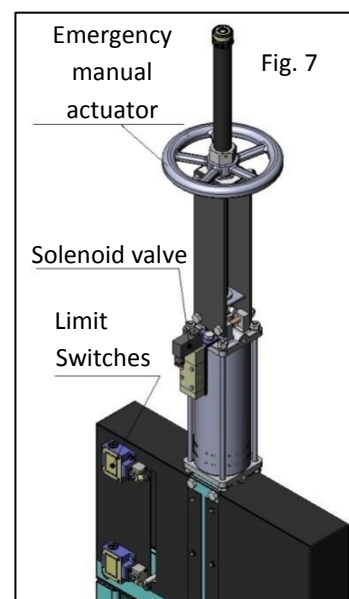

TYPES OF EXTENSION

When the valve needs to be operated from a distance, the following different types of actuators can be fitted:

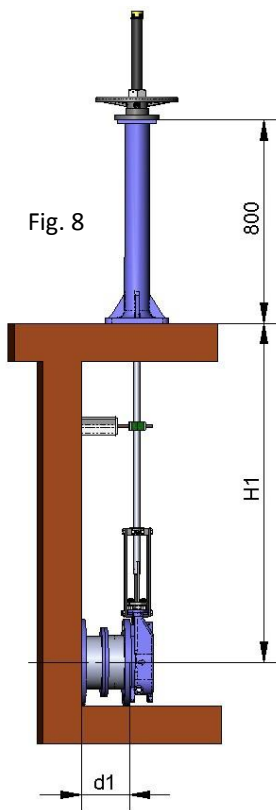

1- Extension: Floor Stand.

This extension is performed by coupling a rod to the stem. By defining the length of the rod, the desired extension is achieved. A floor stand is normally installed to support the actuator.

The definition variables are as follows:

H1: Distance from the valve's shaft to the base of the stand.

d1: Separation from the wall to the end of the connecting flange.

Characteristics:

- It can be coupled to any type of actuator.
- A stem support-guide (Fig. 9) is recommended every 1.5 m.
- The standard floor stand is 800 mm high (Fig.8). Other floor stand measurements available on request.
- A position indicator can be fitted to determine the valve's percentage of opening.
- Possibility of leaning floor stand (Fig.10).

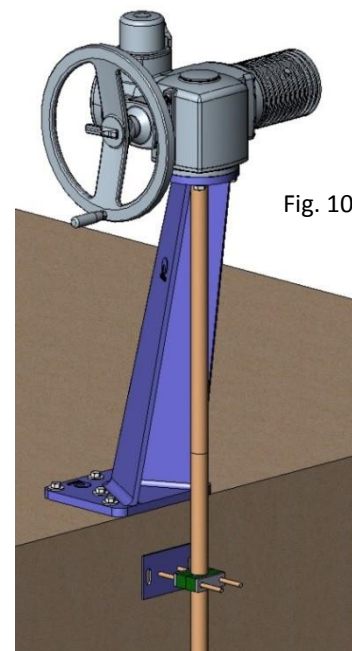
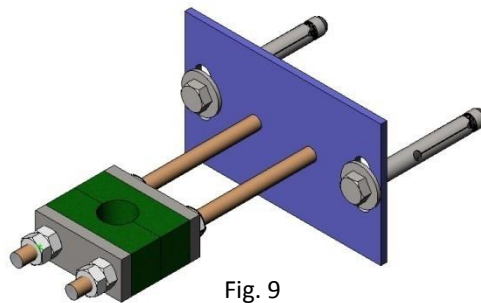

COMPONENTS LIST	
Component	Standard Version
Stem	AISI 303
Rod	AISI 304
Support-Guide	EPOXI-coated carbon steel
Guide	Nylon
Stand	GJS-500 with EPOXI coating

Table 3

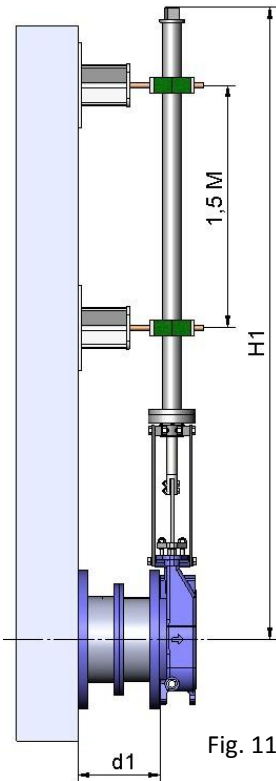

Fig. 11

2- Extension: Pipe (Fig. 11)

Consists of raising the actuator. The pipe will rotate in the same direction as the handwheel when the valve is operated but it always remains at the same height.

The definition variables are as follows:

H1: Distance from the valve's shaft to the desired height of the actuator.

d1: Separation from the wall to the end of the connecting flange.

Characteristics:

- Standard actuators: Handwheel and "Square Nut"
- A pipe support-guide is recommended every 1.5m.
- The standard materials are: EPOXY coated carbon steel or stainless steel.

3 - Extension: Extended Support Plates (Fig. 12)

When a short extension is required, it can be achieved by extending the support plates. An intermediate yoke can be fitted to reinforce the support plates' structure.

Fig. 12

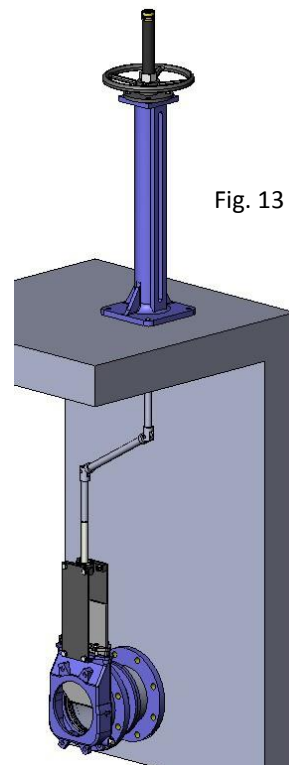
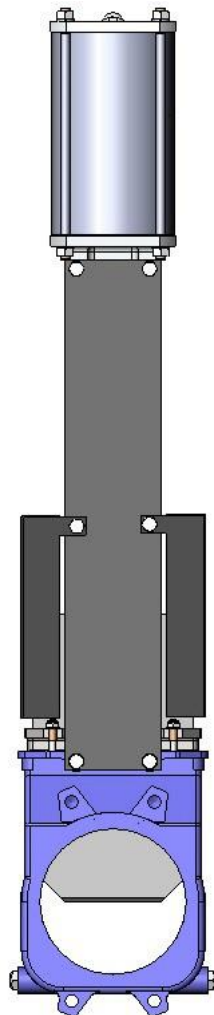

Fig. 13

4 - Extension: Universal Joint (Fig. 13)

If the valve and the actuator are not in correct alignment, the problem can be resolved by fitting a universal joint.

HANDWHEEL with Rising Stem

- **B = Max. width** of the valve (without actuator).
D = Max. height of the valve (without actuator).
- Options:
 - Locking devices.
 - Extensions: stand, pipe, plates...
 - DN higher than those give in the table.
- Actuator including:
 - Handwheel.
 - Stem.
 - Nut.
 - Stem protection hood.
- Available: DN50 to DN1200, other DN on request.
- From DN600 the actuator is with geared motor.

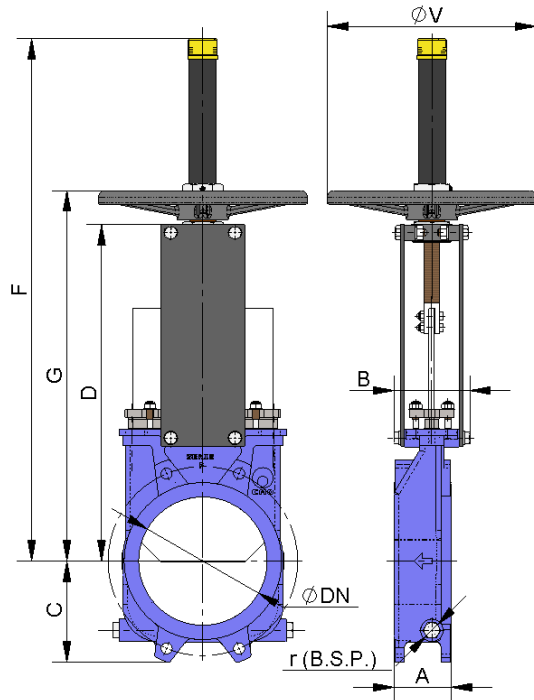

Fig. 14

DN	ΔP (Kg/cm ²)	DRAW (Nw)	TORQUE (Nm)	A	B	C	D	F	G	ϕV	r (B.S.P.)
50	3	360	0.85	60	91	61	241	410	280	225	1/4"
65	3	606	1.4	60	91	68	268	437	308	225	1/4"
80	3	915	2.2	64	91	91	294	463	333	225	1/4"
100	3	1428	3.3	64	91	104	334	503	373	225	1/4"
125	3	2232	5.2	70	101	118	367	586	407	225	3/8"
150	3	3211	7.4	76	101	130	419	638	458	225	3/8"
200	2	3835	11.2	89	118	158	525	816	578	325	3/8"
250	2	5984	17.4	114	118	196	616	1007	669	325	1/2"
300	2	8640	25.1	114	118	230	704	1095	757	380	1/2"
350	1,5	8862	35.1	127	290	247	767	1307	876	450	1/2"
400	1,5	11625	46.1	140	290	290	865	1405	974	450	1/2"
450	1	9949	39.9	152	290	304	989	1629	1098	450	1/2"
500	1	12280	49.3	152	290	340	1101	1741	1210	450	1/2"
600	1	17857	72.1	178	290	398	1307	2047	1416	450	1/2"
700	1	24269	139	178	320	453	1506	2401	1656	--	1/2"
800	1	32180	186	178	320	503	1720	2715	1870	--	1/2"
900	1	40624	234	178	320	583	1953	3043	2103	--	1/2"
1000	1	50884	296	178	320	613	2137	3351	2287	--	1/2"
1200	1	72949	423	203	340	728	2616	4042	2766	--	1/2"

Table 4

HANDWHEEL with Non-Rising Stem

- Suitable when no size limitations exist.
- **B = Max. width** of the valve (without actuator).
D = Max. height of the valve (without actuator).
- Options:
 - Square nut.
 - Locking devices.
 - Extensions: stand, pipe, plates...
 - DN higher than those give in the table.
- Actuator including:
 - Handwheel.
 - Stem.
 - Guide bearings on the yoke.
 - Nut.
- Available: DN50 to DN1200, other DN on request.
- From DN600 the actuator is with geared motor.

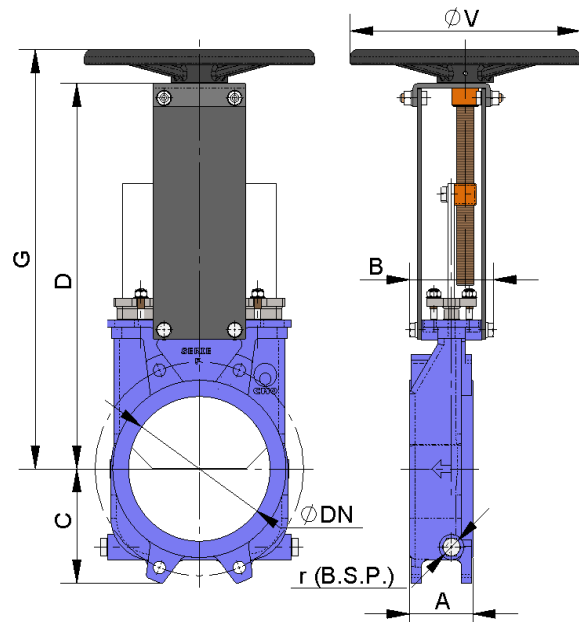

Fig. 15

DN	ΔP (Kg/cm ²)	DRAW (Nw)	TORQUE (Nm)	A	B	C	D	G	ϕV	r (B.S.P.)
50	3	360	0.85	60	91	61	241	280	225	1/4"
65	3	606	1.4	60	91	68	268	308	225	1/4"
80	3	915	2.2	64	91	91	294	333	225	1/4"
100	3	1428	3.3	64	91	104	334	373	225	1/4"
125	3	2232	5.2	70	101	118	367	407	225	3/8"
150	3	3211	7.4	76	101	130	419	458	225	3/8"
200	2	3835	11.2	89	118	158	525	578	325	3/8"
250	2	5984	17.4	114	118	196	616	669	325	1/2"
300	2	8640	25.1	114	118	230	704	757	380	1/2"
350	1,5	8862	35.1	127	290	247	767	876	450	1/2"
400	1,5	11625	46.1	140	290	290	865	974	450	1/2"
450	1	9949	39.9	152	290	304	989	1098	450	1/2"
500	1	12280	49.3	152	290	340	1101	1210	450	1/2"
600	1	17857	72.1	178	290	398	1307	1416	450	1/2"
700	1	24269	139	178	320	453	1506	1656	--	1/2"
800	1	32180	186	178	320	503	1720	1870	--	1/2"
900	1	40624	234	178	320	583	1953	2103	--	1/2"
1000	1	50884	296	178	320	613	2137	2287	--	1/2"
1200	1	72949	423	203	340	728	2616	2766	--	1/2"

Table 5

CHAINWHEEL

- Widely used in raised installations with difficult access, the handwheel is fitted in vertical position.
- **B = Max. width** of the valve (without actuator).
D = Max. height of the valve (without actuator).
- Options:
 - Locking devices.
 - Extensions: stand, pipe, plates...
 - Non-rising stem.
 - DN higher than those give in the table.
- Including:
 - Handwheel.
 - Stem.
 - Nut.
 - Hood.
- Available: DN50 to DN1200, other DN on request.
- From DN600 the actuator is with geared motor, see * in table.

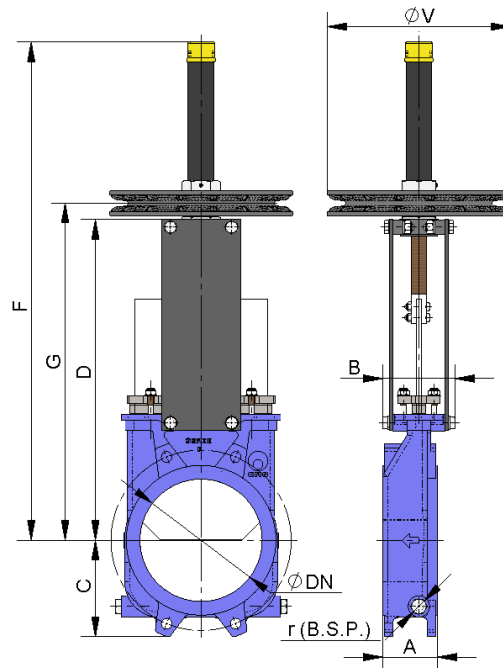

Fig. 16

DN	ΔP (Kg/cm ²)	DRAW (Nw)	TORQUE (Nm)	A	B	C	D	G	F	$\varnothing V$	r (B.S.P.)
50	3	360	0.85	60	91	61	241	280	410	225	1/4"
65	3	606	1.4	60	91	68	268	308	437	225	1/4"
80	3	915	2.2	64	91	91	294	333	463	225	1/4"
100	3	1428	3.3	64	91	104	334	373	503	225	1/4"
125	3	2232	5.2	70	101	118	367	407	586	225	3/8"
150	3	3211	7.4	76	101	130	419	458	638	225	3/8"
200	2	3835	11.2	89	118	158	525	578	816	300	3/8"
250	2	5984	17.4	114	118	196	616	669	1007	300	1/2"
300	2	8640	25.1	114	118	230	704	757	1095	300	1/2"
350	1,5	8862	35.1	127	290	247	767	876	1307	402	1/2"
400	1,5	11625	46.1	140	290	290	865	974	1405	402	1/2"
450	1	9949	39.9	152	290	304	989	1098	1629	402	1/2"
500	1	12280	49.3	152	290	340	1101	1210	1741	402	1/2"
600	1	17857	72.1	178	290	398	1307	1416	2047	402	1/2"
700	1	24269	139	178	320	453	1506	1656	2401	402*	1/2"
800	1	32180	186	178	320	503	1720	1870	2715	402*	1/2"
900	1	40624	234	178	320	583	1953	2103	3043	402*	1/2"
1000	1	50884	296	178	320	613	2137	2287	3351	402*	1/2"
1200	1	72949	423	203	340	728	2616	2766	4042	402*	1/2"

Table 6

LEVER

- It is a fast actuator.
- **B = Max. width** of the valve (without actuator)
D = Max. height of the valve (without actuator).
- The actuator includes:
 - Lever.
 - Rod.
 - Guide bearing.
 - External limiting switches to maintain the position.
- Available: DN50 to DN300.

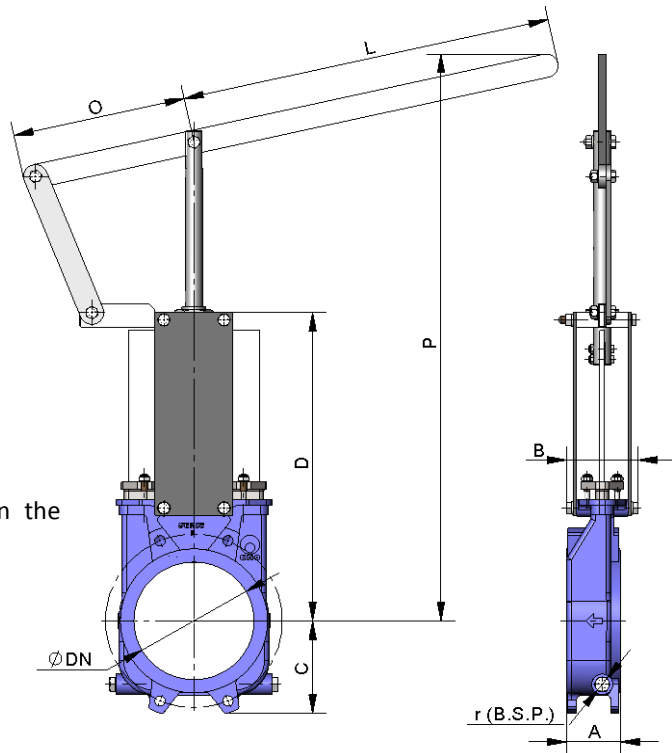

Fig. 17

DN	ΔP (Kg/cm ²)	DRAW (Nw)	A	B	C	D	L	O	P	r(B.S.P.)
50	3	360	60	91	61	241	315	165	509	1/4"
65	3	606	60	91	68	268	315	165	536	1/4"
80	3	915	64	91	91	294	315	165	562	1/4"
100	3	1428	64	91	104	334	315	165	602	1/4"
125	3	2232	70	101	118	367	415	165	896	3/8"
150	3	3211	76	101	130	419	415	165	948	3/8"
200	2	3835	89	118	158	525	620	290	1040	3/8"
250	2	5984	114	118	196	616	620	290	1426	1/2"
300	2	8640	114	118	230	704	620	290	1514	1/2"

Table 7

GEAR BOX

- It is recommendable for DN greater than 600.
- **B = Max. width** of the valve (without actuator).
D = Max. height of the valve (without actuator).
- Options:
 - Chainwheel.
 - Locking devices.
 - Extensions: stand, pipe, plates...
 - Non-rising stem.
- Actuator including:
 - Stem.
 - Yoke.
 - Cone-shaped gear box.
 - Handwheel.
- Standard ratio = 4 to 1.
- Available: DN 50 to DN 1200, other DN on request.

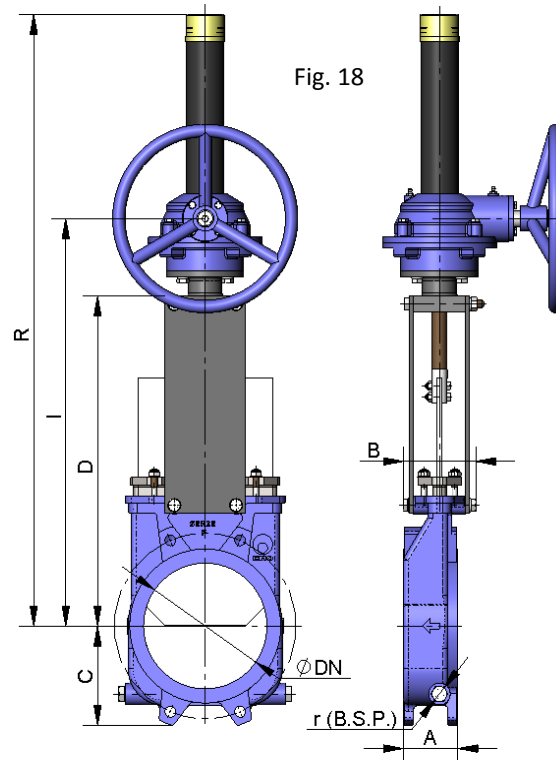

DN	ΔP (Kg/cm ²)	DRAW (Nw)	TORQUE (Nm)	A	B	C	D	I	R	r (B.S.P.)
50	3	360	0.85	60	91	61	241	365	537	1/4"
65	3	606	1.4	60	91	68	268	392	564	1/4"
80	3	915	2.2	64	91	91	294	418	590	1/4"
100	3	1428	3.3	64	91	104	334	458	630	1/4"
125	3	2232	5.2	70	101	118	367	491	663	3/8"
150	3	3211	7.4	76	101	130	419	543	715	3/8"
200	2	3835	11.2	89	118	158	525	649	943	3/8"
250	2	5984	17.4	114	118	196	616	740	1033	1/2"
300	2	8640	25.1	114	118	230	704	828	1121	1/2"
350	1,5	8862	35.1	127	290	247	767	891	1305	1/2"
400	1,5	11625	46.1	140	290	290	865	989	1403	1/2"
450	1	9949	39.9	152	290	304	989	1113	1677	1/2"
500	1	12280	49.3	152	290	340	1101	1225	1788	1/2"
600	1	17857	72.1	178	290	398	1307	1428	1995	1/2"
700	1	24269	139	178	320	453	1506	1658	2401	1/2"
800	1	32180	186	178	320	503	1720	1872	2715	1/2"
900	1	40624	234	178	320	583	1953	2105	3043	1/2"
1000	1	50884	296	178	320	613	2137	2290	3351	1/2"
1200	1	72949	423	203	340	728	2616	2802	4042	1/2"

Table 8

DOUBLE-ACTING PNEUMATIC CYLINDER

- The air supply pressure to the pneumatic cylinder is a minimum of 6 Kg/cm² and a maximum of 10 Kg/cm², the air must be dry and lubricated.
- 10 Kg/cm² is the maximum admissible air pressure. For air pressures below 6 Kg/cm² please consult manufacturer.
- For DN50 to DN300 valves, the cylinder's jacket and covers are made of aluminium, the rod is AISI304, the piston is rubber-coated steel and the O-ring seals are made of nitrile.
- For valves larger than DN300 the covers are made of nodular cast iron or carbon steel.
- On request, we can also supply the actuator made entirely of stainless steel, especially for installation in corrosive atmospheres.
- **B = Max. width** of the valve (without actuator).
D = Max. height of the valve (without actuator).
- Available: DN50 to DN1200, other DN on request.

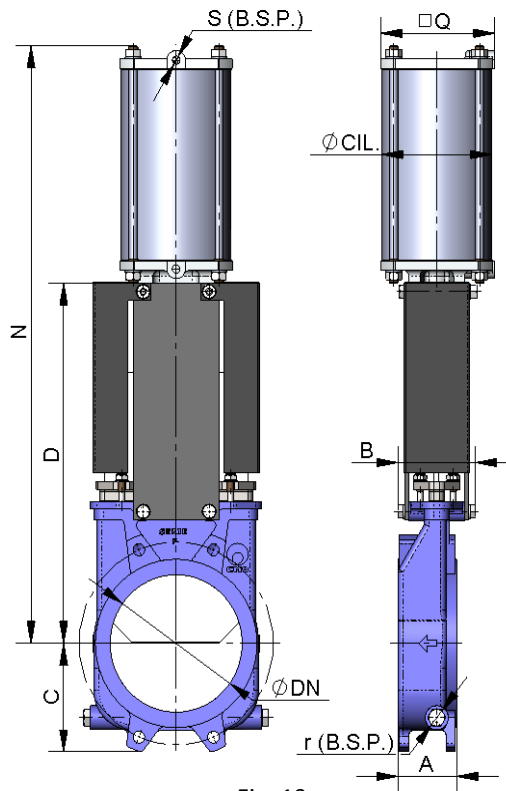

Fig. 19

DN	ΔP (Kg/cm ²)	DRAW (Nw)	A	B	C	D	N	Q	Ø CYL	Ø STEM	S (B.S.P.)	r (B.S.P.)
50	3	360	60	91	61	241	416	90	80	20	1/4"	1/4"
65	3	606	60	91	68	268	456	90	80	20	1/4"	1/4"
80	3	915	64	91	91	294	498	90	80	20	1/4"	1/4"
100	3	1428	64	91	104	334	562	110	100	20	1/4"	1/4"
125	3	2232	70	101	118	367	636	135	125	25	1/4"	3/8"
150	3	3211	76	101	130	419	717	135	125	25	1/4"	3/8"
200	2	3835	89	118	158	525	874	170	160	30	1/4"	3/8"
250	2	5984	114	118	196	616	1036	215	200	30	3/8"	1/2"
300	2	8640	114	118	230	704	1182	215	200	30	3/8"	1/2"
350	1,5	8862	127	290	247	767	1381	270	250	40	3/8"	1/2"
400	1,5	11625	140	290	290	865	1530	270	250	40	3/8"	1/2"
450	1	9949	152	290	304	989	1676	382	300	45	1/2"	1/2"
500	1	12280	152	290	340	1101	1839	382	300	45	1/2"	1/2"
600	1	17857	178	290	398	1307	2145	382	300	45	1/2"	1/2"
700	1	24269	178	320	453	1506	2481	444	350	45	1/2"	1/2"
800	1	32180	178	320	503	1720	2798	444	350	45	1/2"	1/2"
900	1	40624	178	320	583	1953	3167	508	400	50	1/2"	1/2"
1000	1	50884	178	320	613	2137	3451	508	400	50	1/2"	1/2"
1200	1	72949	203	340	728	2616	4133	508	400	50	1/2"	1/2"

Table 9

SINGLE-ACTING PNEUMATIC CYLINDER

- The air supply pressure to the pneumatic cylinder is a minimum of 6 Kg/cm² and a maximum of 10 Kg/cm², the air must be dry and lubricated.
- 10 Kg/cm² is the maximum admissible air pressure. For air pressures below 6 Kg/cm² please consult manufacturer.
- Available for opening or closing in case of air supply failure (spring opening or closing).
- The jacket is made of aluminium, the covers of nodular cast iron or carbon steel, the rod of AISI304, the piston of rubber-coated steel, the O-ring seals of nitrile and the spring is made of steel.
- The **actuator** design is **spring** activated for valves with diameters **up to DN300**. For larger diameters the actuator contains a double-acting cylinder and an air tank which stores the volume of air necessary to perform the last movement in the event of a air supply failure.
- **B = Max. width** of the valve (without actuator).
D = Max. height of the valve (without actuator).
- Available: DN50 to DN300, other DN on request.
- Please see the "CMO Pneumatic Actuators" catalogue if you require further information.

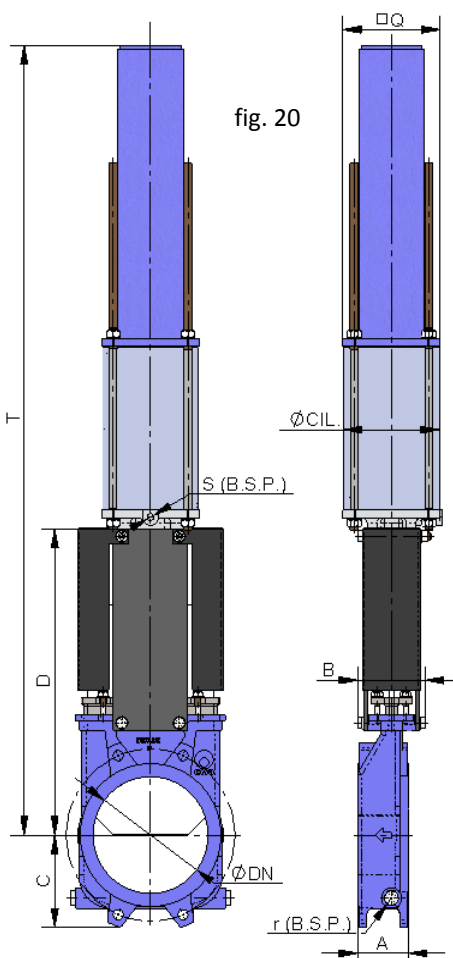

DN	ΔP (Kg/cm ²)	DRAW (Nw)	A	B	C	D	Q	T	\varnothing CYL	\varnothing STEM	S (B.S.P.)	r (B.S.P.)
50	3	360	60	91	61	241	135	781	125	25	1/4"	1/4"
65	3	606	60	91	68	268	135	806	125	25	1/4"	1/4"
80	3	915	64	91	91	294	135	833	125	25	1/4"	1/4"
100	3	1428	64	91	104	334	135	873	125	25	1/4"	1/4"
125	3	2232	70	101	118	367	170	909	160	30	1/4"	3/8"
150	3	3211	76	101	130	419	170	960	160	30	1/4"	3/8"
200	2	3835	89	118	158	525	215	1355	200	30	3/8"	3/8"
250	2	5984	114	118	196	616	270	1844	250	40	3/8"	1/2"
300	2	8640	114	118	230	704	270	2005	250	40	3/8"	1/2"

Table 10

ELECTRIC ACTUATOR

- This actuator is automatic and includes the following parts:
 - Electric motor.
 - Stem.
 - Yoke.
- The electric motor includes:
 - Emergency manual handwheel.
 - Limit switches.
 - Torque switches.
- Options:
 - Different types and brands.
 - Non-rising stem.
- ISO 5210 / DIN 3338 Flanges.
- Available: DN50 to DN1200, other DN on request.
- From DN450 the motor is assisted with a gear box.

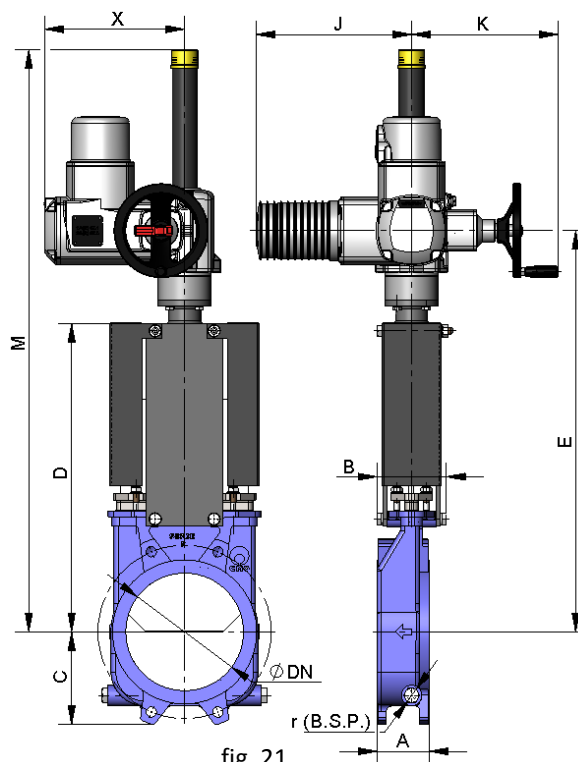

DN	ΔP (Kg/cm ²)	DRAW (Nw)	TORQUE (Nm)	A	B	C	D	E	J	K	M	X	r (B.S.P.)
50	3	360	0.85	60	91	61	241	400	265	250	581	237	1/4"
65	3	606	1.4	60	91	68	268	426	265	250	607	237	1/4"
80	3	915	2.2	64	91	91	294	452	265	250	632	237	1/4"
100	3	1428	3.3	64	91	104	334	492	265	250	672	237	1/4"
125	3	2232	5.2	70	101	118	367	525	265	250	705	237	3/8"
150	3	3211	7.4	76	101	130	419	577	265	250	757	237	3/8"
200	2	3835	11.2	89	118	158	525	683	265	250	988	237	3/8"
250	2	5984	17.4	114	118	196	616	774	265	250	1089	237	1/2"
300	2	8640	25.1	114	118	230	704	862	265	250	1190	237	1/2"
350	1,5	8862	35.1	127	290	247	767	937	282	250	1302	247	1/2"
400	1,5	11625	46.1	140	290	290	865	1035	282	250	1458	247	1/2"
450	1	9949	39.9	152	290	304	989	1153	265	250	1754	382	1/2"
500	1	12280	49.3	152	290	340	1101	1265	265	250	1866	382	1/2"
600	1	17857	72.1	178	290	398	1307	1471	265	250	2073	382	1/2"
700	1	24269	139	178	320	453	1506	1698	282	256	2391	413	1/2"
800	1	32180	186	178	320	503	1720	1912	282	256	2705	413	1/2"
900	1	40624	234	178	320	583	1953	2145	282	256	3033	413	1/2"
1000	1	50884	296	178	320	613	2137	2329	282	256	3328	413	1/2"
1200	1	72949	423	203	340	728	2616	2852	282	256	4047	462	1/2"

Table 11

HYDRAULIC ACTUATOR (Oil pressure: 135 Kg/cm²)

- **B = anchura máx.** de la válvula (sin accionamiento).
D = altura máx. de la válvula (sin accionamiento).
- El accionamiento hidráulico está compuesto por:
 - Hydraulic cylinder.
 - Yoke.
- Available: DN50 to DN1200.
- Different types and brands available according to customer's requirements.

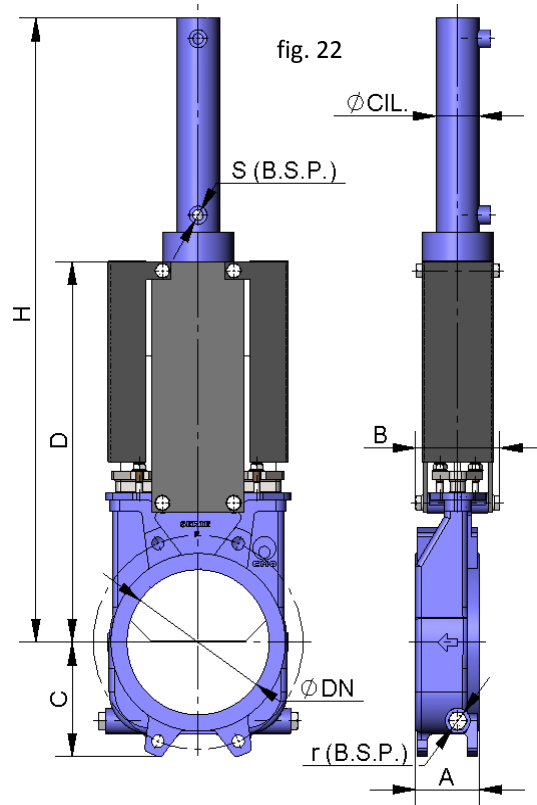

DN	ΔP (Kg/cm ²)	DRAW (Nw)	A	B	C	D	H	Ø CYL	Ø STEM	S (B.S.P.)	Oil Cap (dm ³)	r (B.S.P.)
50	3	360	60	91	61	241	457	25	18	3/8"	0.03	1/4"
65	3	606	60	91	68	268	500	25	18	3/8"	0.03	1/4"
80	3	915	64	91	91	294	560	25	18	3/8"	0.04	1/4"
100	3	1428	64	91	104	334	620	32	22	3/8"	0.09	1/4"
125	3	2232	70	101	118	367	683	32	22	3/8"	0.11	3/8"
150	3	3211	76	101	130	419	755	40	28	3/8"	0.20	3/8"
200	2	3835	89	118	158	525	926	50	28	3/8"	0.42	3/8"
250	2	5984	114	118	196	616	1077	50	28	3/8"	0.52	1/2"
300	2	8640	114	118	230	704	1246	50	28	3/8"	0.62	1/2"
350	1,5	8862	127	290	247	767	1376	50	28	3/8"	0.73	1/2"
400	1,5	11625	140	290	290	865	1532	63	36	3/8"	1.31	1/2"
450	1	9949	152	290	304	989	1707	63	36	3/8"	1.47	1/2"
500	1	12280	152	290	340	1101	1869	63	36	3/8"	1.62	1/2"
600	1	17857	178	290	398	1307	2176	80	45	3/8"	3.12	1/2"
700	1	24269	178	320	453	1506	2525	80	45	3/8"	3.62	1/2"
800	1	32180	178	320	503	1720	2839	100	56	1/2"	6.44	1/2"
900	1	40624	178	320	583	1953	3172	100	56	1/2"	7.25	1/2"
1000	1	50884	178	320	613	2137	3496	125	70	1/2"	10.25	1/2"
1200	1	72949	203	340	728	2616	4175	125	70	1/2"	15.1	1/2"

Table 12

INFORMATION ON FLANGE DIMENSIONS
EN 1092-2 PN10

DN	ΔP (Kg/cm ²)	●	○	Metric	P	ØK
50	3	4	-	M 16	8	125
65	3	4	-	M 16	8	145
80	3	4	4	M 16	10	160
100	3	4	4	M 16	10	180
125	3	4	4	M 16	10	210
150	3	4	4	M 20	12	240
200	2	4	4	M 20	10	295
250	2	8	4	M 20	12	350
300	2	8	4	M 20	12	400
350	1,5	12	4	M 20	21	460
400	1,5	12	4	M 24	21	515
450	1	16	4	M 24	21	565
500	1	16	4	M 24	21	620
600	1	16	4	M 27	20	725
700	1	20	4	M 27	25	840
800	1	20	4	M 30	22	950
900	1	24	4	M 30	21	1050
1000	1	24	4	M 33	21	1160
1200	1	28	4	M 36	30	1380

Table 13

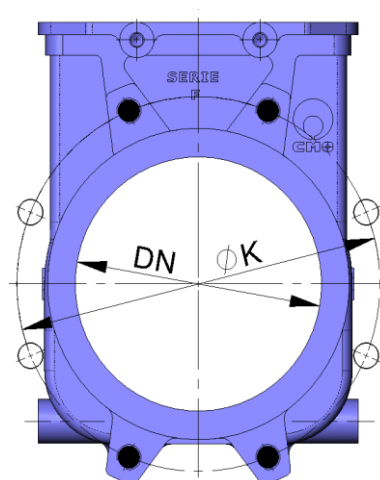

fig.23

- BLIND TAPPED HOLE
- THROUGH HOLE

ANSI B16, class 150

DN	ΔP (Kg/cm ²)	●	○	R LINC	P	ØK
2"	3	4	-	5/8"	8	120,6
2 1/2"	3	4	-	5/8"	8	139,7
3"	3	4	-	5/8"	10	152,4
4"	3	4	4	5/8"	10	190,5
5"	3	4	4	3/4"	10	215,9
6"	3	4	4	3/4"	12	241,3
8"	2	4	4	3/4"	10	298,4
10"	2	8	4	7/8"	12	361,9
12"	2	8	4	7/8"	12	431,8
14"	1,5	8	4	1"	21	476,2
16"	1,5	12	4	1"	21	539,7
18"	1	12	4	1 1/8"	21	577,8
20"	1	16	4	1 1/8"	21	635
24"	1	16	4	1 1/4"	20	749,3
28"	1	24	4	1 1/4"	25	863,6
32"	1	24	4	1 1/2"	21	977,9
36"	1	28	4	1 1/2"	21	1085,9
40"	1	32	4	1 1/2"	21	1200,2

Table 14

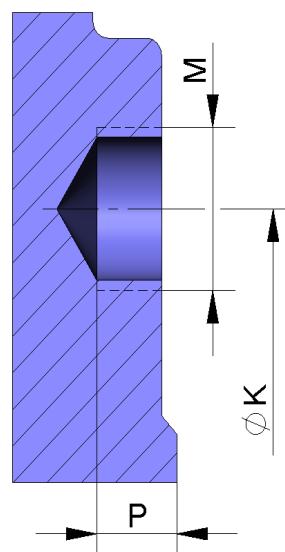

fig. 24