



**TUBI
VALVES**



KTM - MEGA FRANCE



KTM Mecafrance Series RA World Class Ball Valves

KTM Mecafrance ball valves set the industry standard, designed to last longer, extend cycle life and lower the cost of ownership. KTM Mecafrance is part of the Emerson portfolio of Final Control products. At Emerson we understand the importance of keeping your process running continuously, regardless of the conditions, which is why we are dedicated to providing the highly reliable technologies that will help you control, regulate and isolate your process with absolute certainty.

With a reputation for high quality and world class innovation, KTM Mecafrance ball valves are used by the major process industries round the world. Each valve is precision manufactured from foundry casting or forgings to final assembly.

Total quality control for every component is maintained from start to finish ensuring KTM Mecafrance ball valves provide long lasting, dependable service.

At Emerson, we offer our customers not only the most comprehensive range of products, technologies, and services in the industry, but the confidence that comes from working with a single-trusted-partner.

So, when you need a premier global valve business that will help you operate safely, improve reliability, and optimize plant performance, just think Tubi Valves.

Series RA

Designed around your needs



Series RA Ball Valves

The Series RA is a three-piece ball valve with swing-out center section for easy seat and gasket replacement. It is available as full and reduced bore with a cast body in either carbon or stainless steel, the ISO top flange allows for easy automation.

Connections:

Butt weld, socket weld, threaded ends and flanged* version

Size range:

DN 8 - DN 200

Pressure range:

PN10 - PN100, ANSI 150/300

Temperature range:

-50°C to +400°C

For details see pages 14 and 15



Metal Seated Valves

Series RA ball valves are also available with metal seats for corrosive and abrasive services at elevated temperatures up to 400°C. These can be fitted in all standard KTM Mecafrance 3-piece ball valves without further modifications.

For details see pages 18 and 19



Cryogenic Service

The series RA is available for cryogenic services at temperatures to -196°C with 150 or 300 mm extensions (other lengths on request). They can also be supplied to comply with EN 1626 (on request).

Connections:

Butt weld, socket weld, threaded ends and flanged* versions

Size range:

DN 8 - DN 150

Pressure range:

PN10 - PN100, ASME 150/300
mono-directional

Temperature range:

-196°C to +80°C

For details see pages 20 and 21



Manual Operators

KTM Mecafrance ball valves are available with a range of manual operators, including high and low-profile handles and a locking version. They can also be supplied with a spring return handle (dead man's handle) as either spring to open or spring to close, with a double inside stop to avoid injury. For details see pages 22 and 23.



In-line maintenance

The Series RA has a single bolt removal swing-out design, with ISO 5211 type centers for simplified in-line maintenance of all internal parts. Single bolt removal also minimizes pipe twisting or distortion during maintenance. Larger valves use a similar lift out feature.



Automated Valve Solutions

Tubi Valves can supply you with a fully engineered, integrated and configured automated ball valve from a single source. We will manage, administer and produce your automated valve and as we manufacture all the components required we are totally responsible and accountable for the solutions we supply. Having one supplier will minimize risk and commissioning complexities, whilst also ensuring on-time delivery and project certainty.

* Available in Europe only.

Series RA

Suitable for a range of applications

KTM Mecafrance ball valves are suitable for most applications from industrial and utilities to heavy-duty working conditions, including corrosive or hazardous services. In addition to the standard product, valves are available for specific applications.

Hazardous Areas

The series RA is available with a specially designed Anti-Static device suitable for environments with ATEX area classifications. Valves can be supplied with A2 marking, suitable for installation in all zones 1 & 21 and zones 2 & 22 (according to the ATEX Directive 1999/92/EC annex II). Max. temperature +150°C.

Control accessories can also be mounted on actuators and solenoid connections that comply with VDI/VDE 3845.

Please enquire for further details.

Pressure Equipment Directive (2014/68/EU)

Series RA valves and actuators are available to comply with the most stringent requirements of the European Directives and harmonized standards including Pressure Equipment Directive (2014/68/EU). This includes:

- Valves certified to module H of PED, allowing applications up to and including category III (the highest category for industrial valves, table 6 of the PED annex II)
- Actuators falling under article 3, paragraph 3 of the PED which are produced in an environment certified to both ISO 9001 and PED module H



Series RA 3-piece ball valve

Exploded view

Reduced bore DN 15 - DN 50; CBS/CSW/CBG

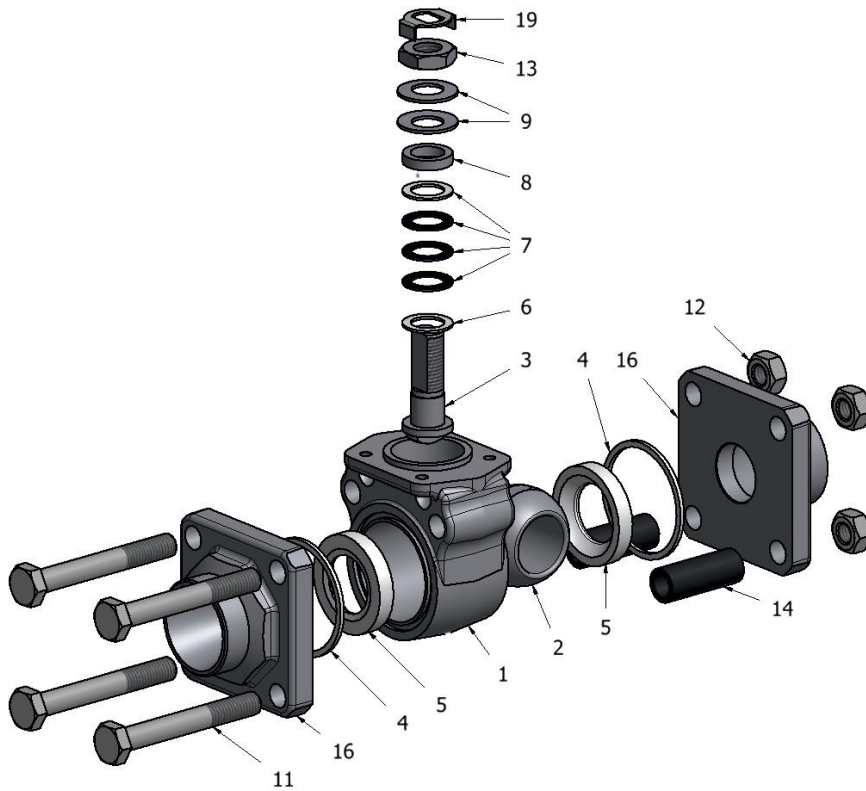

Reduced bore DN 15 - DN 50; CBF (option for Europe only)

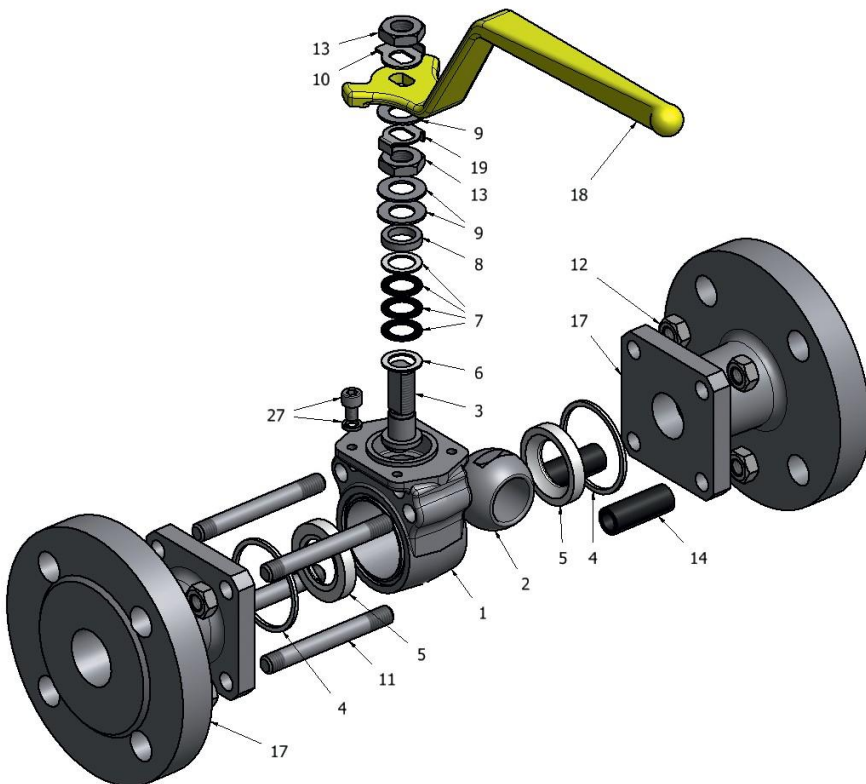

Parts List

No.	Description
1	Body
2	Ball
3	Stem
4	Body gasket
5	Seat
6	Stem seal
7	Stem packing
8	Stem packing follower
9	Belleville washer
10	Lock washer
11	Bolt/Body bolt
12	Nut
13	Stem nut
14	Sleeve
16	End connection
17	Flange end
18	Handle
19	Lock washer
27	Travel stop

Please follow assembly and maintenance instructions carefully.

Series RA

Material specification

No	Description	Valves of carbon steel		Valves of stainless steel	
		DIN	AISI/ASTM	DIN	AISI/ASTM
1	Body	1.0619, P240GH	A105/ A216 WCB	1.4408	316 / CF8M
2	Ball	1.4408	1.4408	1.4408	316 / CF8M
3	Stem	1.4462	Duplex	1.4462	Duplex
4	Body gasket	PTFE, PTFE-graphite (TF4215) [®] , graphite, PEEK, polyethylene, PCTFE, FPM, TFM1600	PTFE, PTFE-graphite (TF4215) [®] , graphite, PEEK, polyethylene, PCTFE, FPM, TFM1600	PTFE, PTFE-graphite (TF4215) [®] , graphite, PEEK, polyethylene, PCTFE, FPM, TFM1600	PTFE, PTFE-graphite (TF4215) [®] , graphite, PEEK, polyethylene, PCTFE, FPM, TFM1600
5	Seat	TFM1600, PTFE, PTFE-graphite (TF4215) [®] , PTFE glass filled, PEEK, polyethylene, metal	TFM1600, PTFE, PTFE-graphite (TF4215) [®] , PTFE glass filled, PEEK, polyethylene, metal	TFM1600, PTFE, PTFE-graphite (TF4215) [®] , PTFE glass filled, PEEK, polyethylene, metal	TFM1600, PTFE, PTFE-graphite (TF4215) [®] , PTFE glass filled, PEEK, polyethylene, metal
6	Stem seal	PTFE-glass-reinforced, PTFE-graphite, PE Nitralon (HP), TFM1600, PEEK, FPM, PCTFE	PTFE-glass-reinforced, PTFE-graphite, PE Nitralon (HP), TFM1600, PEEK, FPM, PCTFE	PTFE-glass-reinforced, PTFE-graphite, PE Nitralon (HP), TFM1600, PEEK, FPM, PCTFE	PTFE-glass-reinforced, PTFE-graphite, PE Nitralon (HP), TFM1600, PEEK, FPM, PCTFE
7	Stem packing (antistatic)	PTFE-GFK antistatic, PTFE graphite, PTFE FPM [®] , TFM1600, polyethylene, PEEK, FPM, PCTFE	PTFE-GFK antistatic, PTFE graphite, PTFE FPM [®] , TFM1600, polyethylene, PEEK, FPM, PCTFE	PTFE-GFK antistatic, PTFE graphite, PTFE FPM [®] , TFM1600, polyethylene, PEEK, FPM, PCTFE	PTFE-GFK antistatic, PTFE graphite, PTFE FPM [®] , TFM1600, polyethylene, PEEK, FPM, PCTFE
8	Stem packing follower	1.4301	304	1.4301	304
9	Belleville washer	1.431	302	1.431	302
10	Lock washer	1.4306	304L	1.4306	304L
11	Body screw/bolts	8.8	A 193 B 7	A 2-70	A 193 B 8
12	Nut	8	A 194 2 H	A 2-70	A 194 8
13	Stem nut	1.0715	115	1.4301	304
14	Sleeve	PTFE	PTFE	PTFE	PTFE
15	Centering ring	PTFE-glass-reinforced, stainless steel, polyethylene	PTFE-glass-reinforced, stainless steel, polyethylene	PTFE-glass-reinforced, stainless steel, polyethylene	PTFE-glass-reinforced, stainless steel, polyethylene
16	End connection (welded or threaded)	1.0460	A105	1.4404	316L
17	Flange end	1.0619/ 1.0460	A105/ A216 WCB	1.4404/ 1.4408	316L/ CF8M
18	Lever	C15, stainless steel	A105, stainless steel	C15, stainless steel	A105, stainless steel
19	Lock washer	1.4306	304L	1.4306	304L
20	Stop	Cast iron	Cast iron	1.4308	CF-8
23	Washer	1.4301	304	1.4301	304

Series RA Function

Ball Sealing

The principle of the ball valves lies in the use of a ported spherical ball, which is rotated between two seats normally made of PTFE. The seats have flexible lips designed so that the ball, when rotated, follows the spherical contours of the port way. This floating bearing permits movement in the direction of flow, thereby ensuring optimal sealing of the port way.

Figure 1: in the absence of pressure, a proper seal is assured in that the spring action of the seats presses the sealing lips to the ball; the sealing lips' contact area with the ball is the same on both the upstream and downstream sides.

Figure 2: pressure increases on the upstream side move the ball slightly towards the seat on the downstream side, increasing its pressure against the seat on the downstream side. The seats are designed so that the increase in pressure of the ball on the downstream seat results in all increase in the surface contact area, thus preventing any leakage. In addition, such a pressure increase decreases the pressure against the sealing lips on the upstream side. As a result, the operating torque for the valves remains constant throughout the valve's entire pressure range.

Figure 1

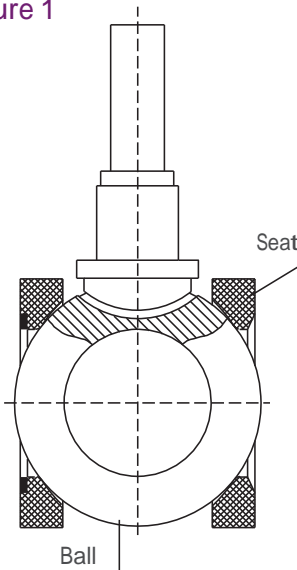

Figure 2

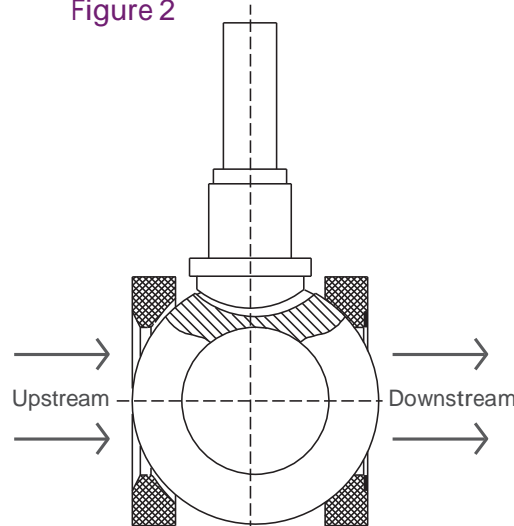
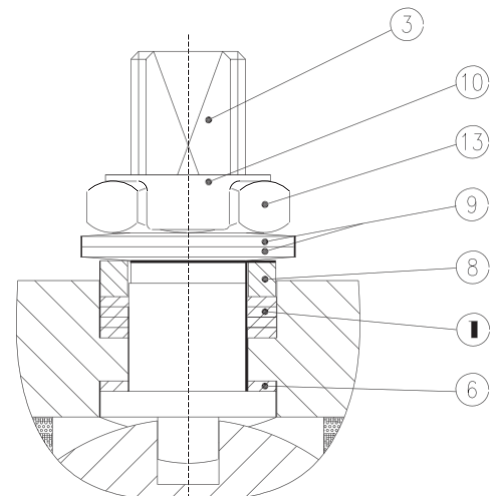

Figure 3



Sealing the Stem

Figure 3: The stem of the KTM Mecafrance ball valve is fitted from inside. A collar, which is larger than the bore in the body, keeps the stem from being pressed out even under extreme internal pressures. The seat washer inside the stem provides the primary seal. Any increase in the internal pressure automatically increases the pressure on the stem collar which, in turn, raises the pressure on the seat seal and the tightness to the outside. For the depressurized state and vacuum mode, the seals are tightened with the secured stem nut acting on Belleville spring washers and a stem seal follower; this prevents any leakage. During the vacuum mode, the situation is reversed to the evacuated side.

Parts List

No.	Description
3	Stem
6	Stem seal
7	Stem packing
8	Stem packing follower
9	Belleville washer
10	Lock washer
13	Stem nut

Kv Values and Pressure Losses

For 2-way valves

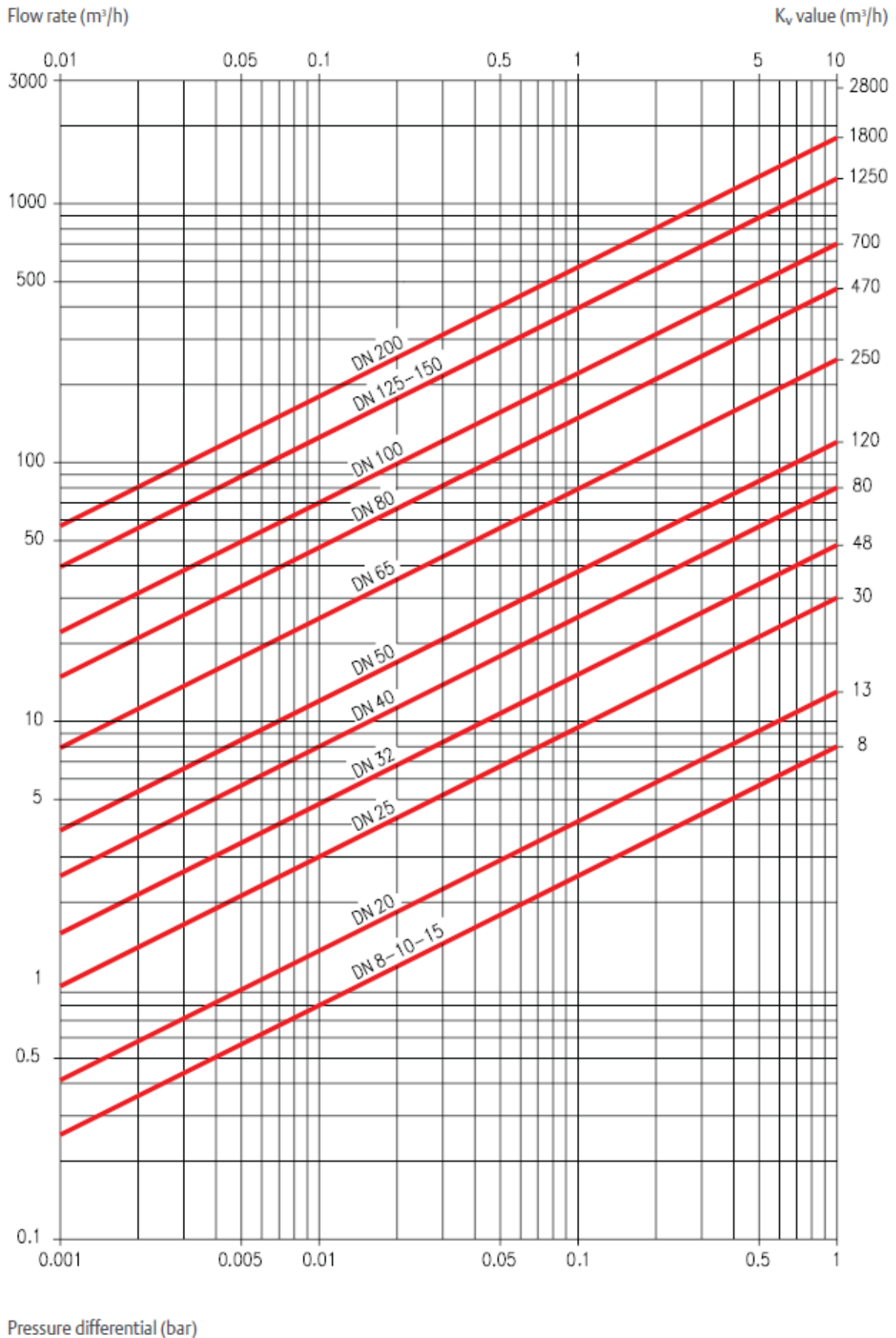

Seat Ratings Pressure and Temperature



TFM 1600 PTFE/PFA Copolymer
Standard seat

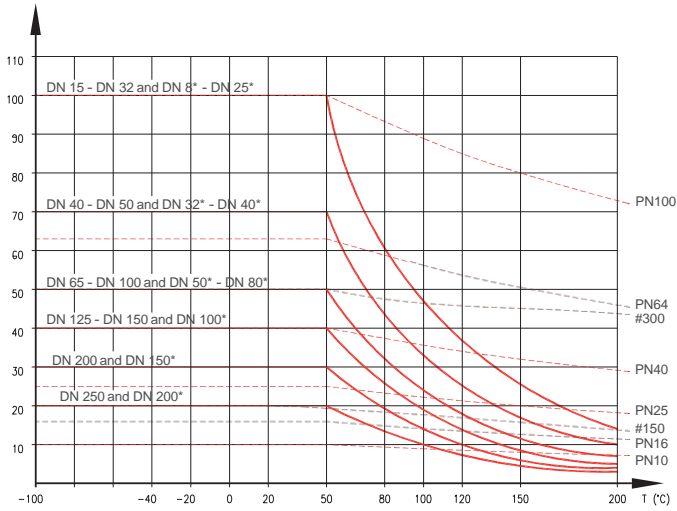

PTFE Carbon Filled (TF4215)[®]
For high temperature and cryogenic applications

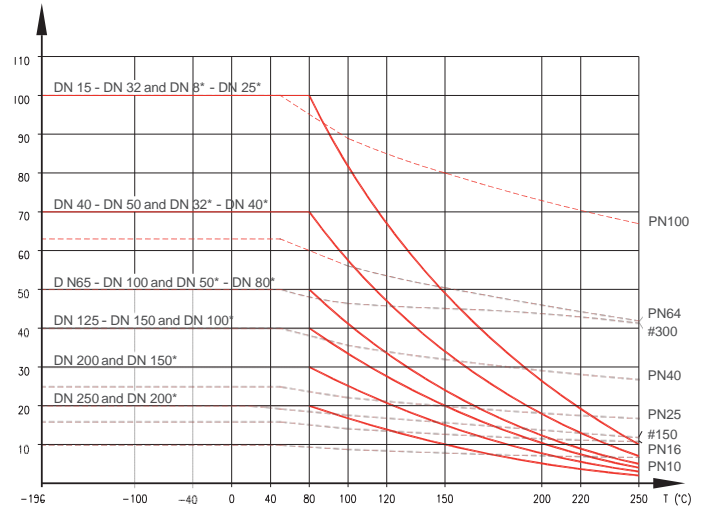

PTFE
For most industrial applications

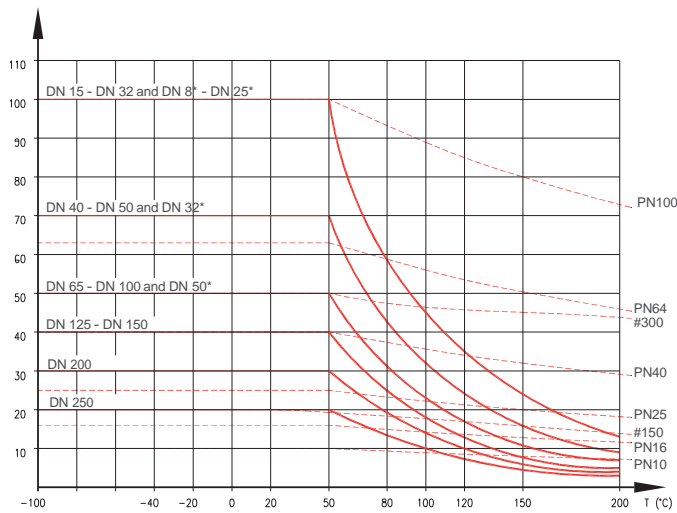

PEEK
For elevated temperature applications

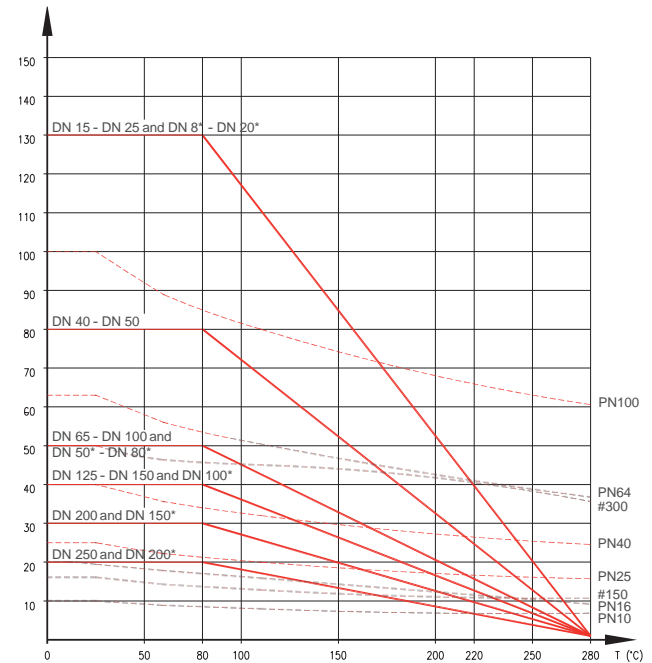



Polyethylene (UHMWPE)



Metal Seat

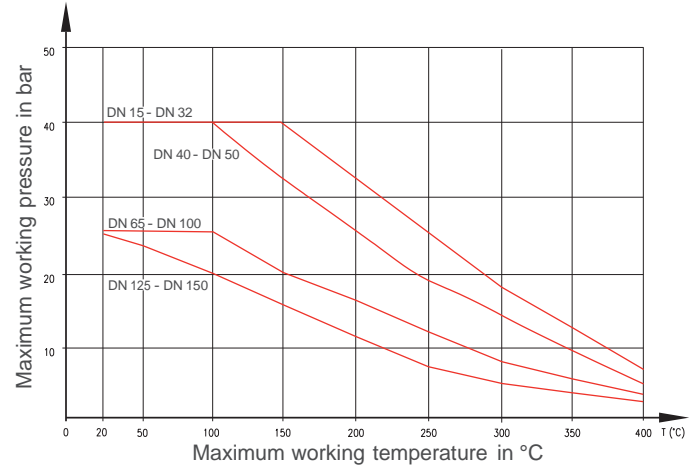
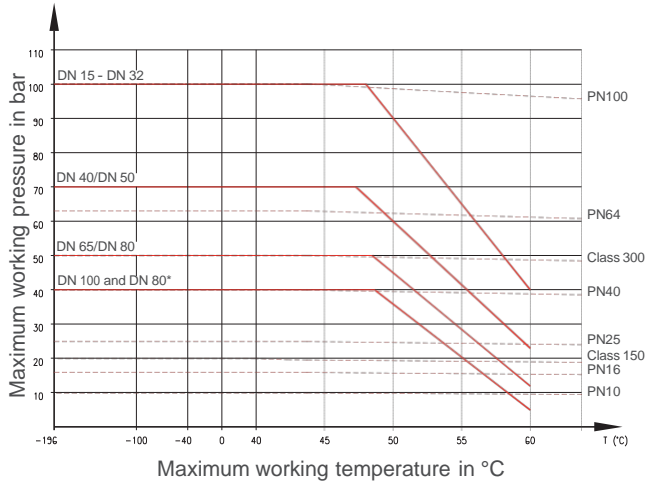

Notes

- * Full bore
- Please always verify maximum body ratings as each above mentioned diagram presents data for the seat material only
- For other material options, please contact Tubi Valves

Construction/ design

Temperature	Description
-10°C < T < 400°C	Ball valve in carbon steel or stainless steel following the application with bolt in stainless steel only
-50°C < T < -10°C	Ball valve and bolt in stainless steel

Body Seals

Details and Operating Torques

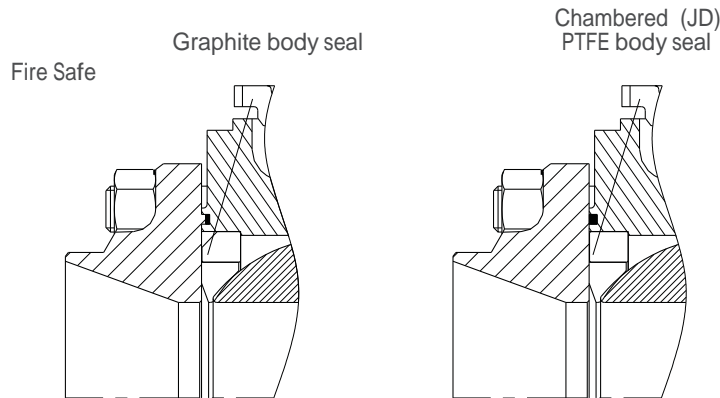

Valve break away torques (Nm)

DN		PTFE/TM1600 seats Δp (bar)							
RB	FB	0	6	10	16	25	40	64	100
15	8/10	5	5	5	5	5	9	16	26
20	15	6	6	6	6	6	10	17	27
25	20	11	11	11	11	11	13	19	30
32	25	18	18	18	18	18	22	27	36
40	32	24	24	24	24	24	30	40	55
50	40	30	30	30	30	30	35	35	60
65	50	60	60	60	65	78	102	140	-
80	65	95	95	95	105	120	155	215	-
100	80	155	155	155	165	180	215	275	-
125/150	100	215	215	215	230	250	300	-	-
200	150	325	360	385	400	420	505	-	-
250	200	420	480	720	765	840	-	-	-

DN		PTFE/GFK, HT, HP (Delrin®), CI, PEEK seats Δp (bar)							
RB	FB	0	6	10	16	25	40	64	100
15	8/10	6	6	6	6	6	11	19	31
20	15	7	7	7	7	7	13	20	32
25	20	13	13	13	13	13	17	24	36
32	25	22	22	22	22	22	26	34	43
40	32	29	29	29	29	29	36	48	65
50	40	36	36	36	36	36	43	55	72
65	50	72	72	72	81	94	122	170	-
80	65	115	115	115	125	145	190	260	-
100	80	180	180	180	190	210	250	315	-
125/150	100	250	250	250	265	290	350	-	-
200	150	370	415	450	460	485	580	-	-
250	200	480	550	830	885	970	-	-	-

DN		Cryogenic PTFE seats Δp (bar)							
RB	FB	0	6	10	16	25	40	64	100
15	8/10	7	7	7	7	7	14	24	40
20	15	10	10	10	10	10	16	26	41
25	20	17	17	17	17	17	20	29	46
32	25	28	28	28	28	28	32	42	54
40	32	36	36	36	36	36	46	60	82
50	40	46	46	46	46	46	54	68	88
65	50	90	90	90	100	118	154	210	-
80	65	144	144	144	155	180	235	320	-
100	80	235	235	235	250	270	325	410	-
125/150	100	325	325	325	345	380	450	-	-
200	150	485	540	575	595	630	755	-	-
250	200	630	720	1080	1150	1260	-	-	-

Body Seal

A specially formed PTFE ring, the body gasket, provides the seal to the outside between the body gaskets and the opposing flange.

The KTM Mecafrance fire-safe design use a tongue and groove connection sealed with temperature-resistant graphite material. High temperatures cause the PTFE seat to vaporize; this, in turn, causes the floating ball to be pressed against the sealing lip during pressure equalization. This results in a metallic linear seal of very high specific are pressure and great reliability. The stem, which has been fitted from inside, is prevented from being pushed out by means of its collar. Even if the PTFE steam seals are destroyed, the collar is still pressed against the turned face in the duct, and the tightness increases as the pressure rises.

Both the ball and the stem are sealed off by a metal-to-metal seal if the valve is closed in case of a fire.

Notes

- RB = reduced bore
- FB = full bore
- Operating torque in Nm, in clean water at room temperature
- For the actuator torque, multiply above value by 1.5
- For non lubricating media, please add 20% to the torques specified

Body Bolting Pattern

Flange Bolting Torques and Packing Torques

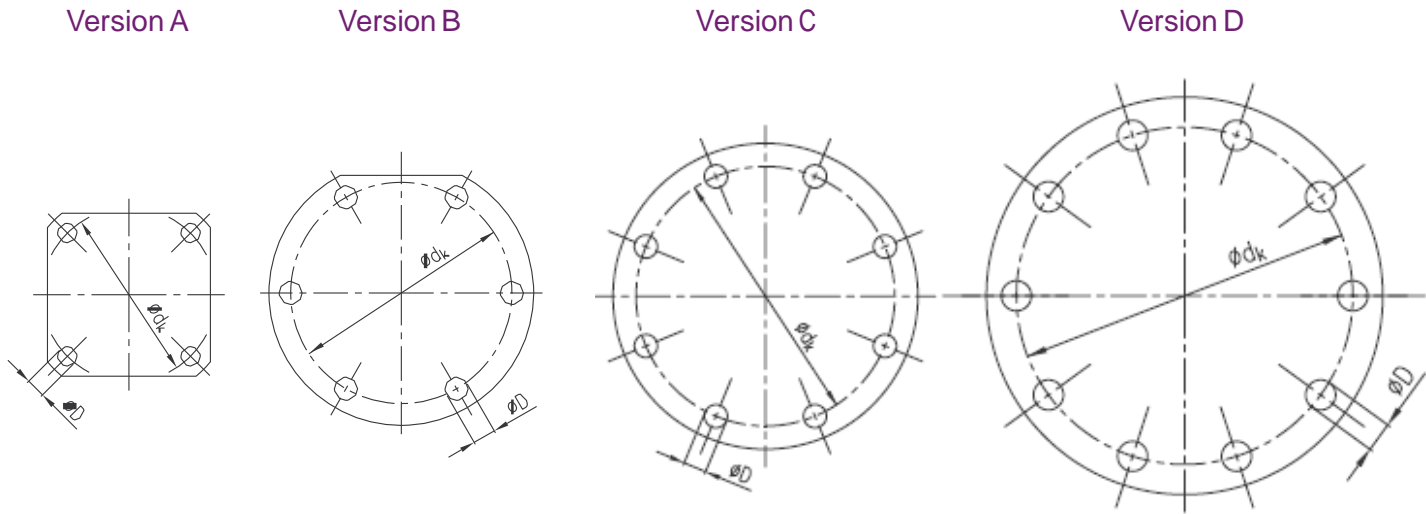

Dimensions for Master gauge for holes (mm)

DN	RB	FB	Ø D	Ø dk	Screws	Series	Version
15	8/10		6.5	45.0	4 x M6	RA	A
20	15		8.5	53.1	4 x M8	RA	A
25	20		8.5	62.8	4 x M8	RA	A
32	25		8.5	71.8	4 x M8	RA	A
40	32		10.5	80.9	4 x M10	RA	A
50	40		10.5	94.2	4 x M10	RA	A
65	50		13.0	114.0 ^[1] 119.5 ^[2]	6 x M12	RA	B
80	65		13.0	140.0	6 x M12	RA	C
100	80		15.0	175.0	8 x M14	RA	C
125/150	100		15.0	206.0	8 x M14	RA	C
200	150		19.0	314.0	8 x M18	RA	C
250	200		22.0	388.0	10 x M20	RA	D

Notes

- Direct from the factory, body screws are tightened with the indicated torques. These torques are for undamaged threads, direct from the factory.
 - After tightening the stem nut with the specified torque, the correct position of the lock washer, according to our assembly and maintenance instructions, has been ensured.
 - Indicated torques are applied during the assembly process.
 - * RB = reduced bore (standard), FB = full bore
1. Stainless steel
 2. Carbon steel
 3. Reinforced version stem 18 mm

Torque Series RA

Body screws and nuts				
DN	RB*	FB*	Md (Nm)	
-		8	M6	11-13
15	10		M6	11-13
20	15		M8	14-18
25	20		M8	14-18
32	25		M8	14-18
40	32		M10	27-33
50	40		M10	27-33
65	50		M12	72-88
80	65		M12	72-88
100	80		M14	108-132
125/150	100		M14	108-132
200	150		M18	180-220
250	200		M20	243-297

Torque Series RA

Stem nuts**			
DN	RB*	FB*	Md (Nm)
15/20		8/10/15	8
25/32		20/25	14
40/50/65		32/40/50	20
65 ^[3]		50 ^[3]	39
80/100/125/150		65/80/100	85
200		150	200
250		200	270

** PTFE/GFK antistatic packing assembly

Series RA

DN 8 - DN 50



RA 66 CBS DN 25

3-piece ball valves with ISO top flange DN 8 - DN 50
Butt weld, threaded, socket weld and flanged version.

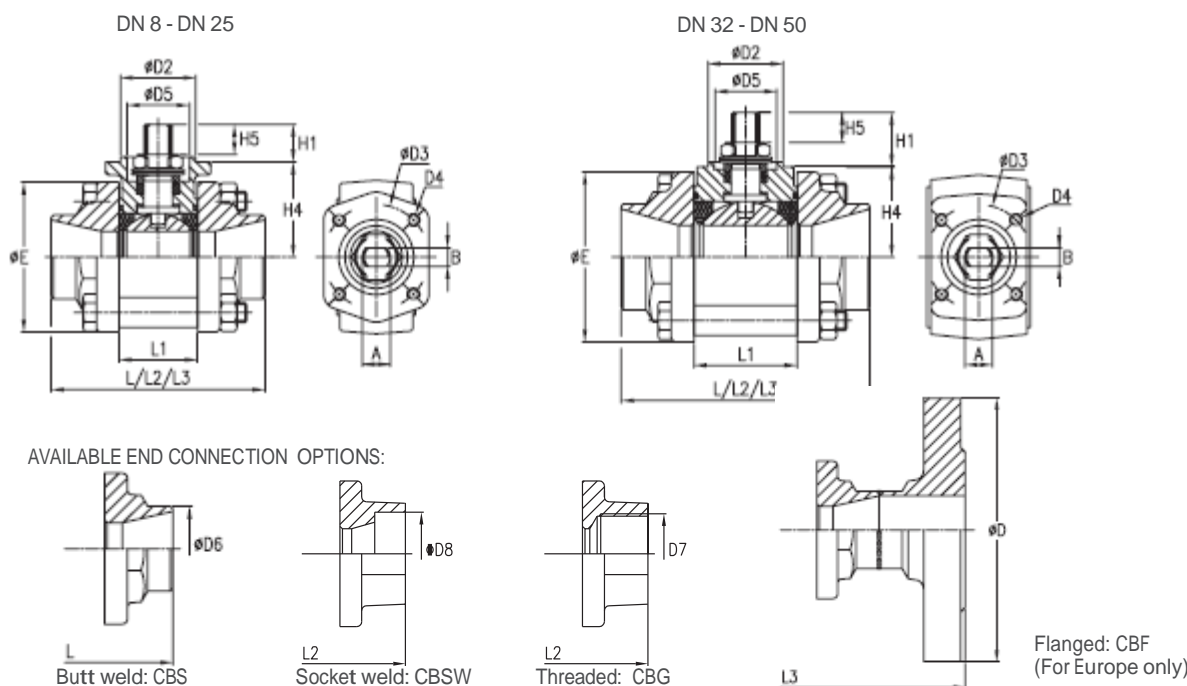

Design Features

- ISO top flange according DIN/ISO 5211/DIN 3337 available with or without handle
- Easy installation of all types of actuators
- Swing out body for easy maintenance
- Flexible installation features due to modular design
- Reduced and full bore options available
- Carbon steel and stainless steel body, stainless steel trim
- Forged end connections
- Cast body materials
- Wide variety of seat material options available

Technical Details

- Threaded ends: BSPP, BSPT according to ISO 7, BSPP according to ISO 228-1, DIN 259 (CBB) NPT according ANSI B 1.20
- Socked weld (CBSW): Female socket weld ANSI B16.11
- Butt weld (CBS): ISO, DIN, ASME, OD, extended OD
- Flanged (CBF): Cast and forged design EN 1092-1, EN 1759-1 Standard Face-to-Face according EN 558 series 1
- Design codes: DIN 3840, EN 13445
- Special end connections are available on request
- Pressure rating: PN10 - PN100

Dimensions (mm)

DN	ISO 5211	L	L1	L2	L3			H4	H5	ϕE	ϕD	$\phi D2$	$\phi D3$	D4	$\phi D5$	$\phi D6$	D7	$\phi D8$	A	B	Weight (kg)		
					series 1	H1	H1														Ball bore	CBS	CBSW
8	F03	65.0	20.4	65.0	-	10	30	7	45	-	25	36	M5	22	13.5	1/4"	14.2	9.5	5.4	11.1	0.5	0.5	-
10	F03	65.0	20.4	65.0	130	10	30	7	45	90	25	36	M5	22	17.2	3/8"	17.6	9.5	5.4	11.1	0.5	0.5	2.2
15	F03	65.0	20.4	65.0	130	10	30	7	45	95	25	36	M5	22	21.3	1/2"	21.8	9.5	5.4	11.1	0.5	0.5	2.3
20	F03	72.5	24.5	72.5	150	10	32	7	52	105	25	36	M5	22	26.9	3/4"	27.4	9.5	5.4	14.2	0.8	0.9	3.0
25	F04	85.4	31.4	85.4	160	15	38	12	60	115	30	42	M5	25	33.7	1"	34.2	11.1	7.5	20.6	1.1	1.3	3.8
32	F04	99.3	41.3	99.3	180	22	36	12	68	140	30	42	M5	25	42.4	1 1/4"	43.0	11.1	7.5	25.4	1.7	1.9	6.0
40	F05	110.4	48.4	110.4	200	29	42	16	76	150	35	50	M6	30	48.3	1 1/2"	49.0	14.3	8.9	31.7	2.7	2.7	7.3
50	F05	126.3	56.3	126.3	230	30	46	16	88	165	35	50	M6	30	60.3	2"	61.1	14.3	8.9	38.0	3.8	4.1	10.0

Notes

All dimensions are related to reduced bore valves. For full bore valves please apply the dimensions of the next diameter(except L3, ϕD , $\phi D6$, D7 and $\phi D8$ which is identical in both instances)

Series RA

DN 65 - DN 200



RA 66 CBS - DN 100

3-piece ball valves with ISO top flange DN 65 - DN 250
Butt weld, threaded, socket weld and flanged version.

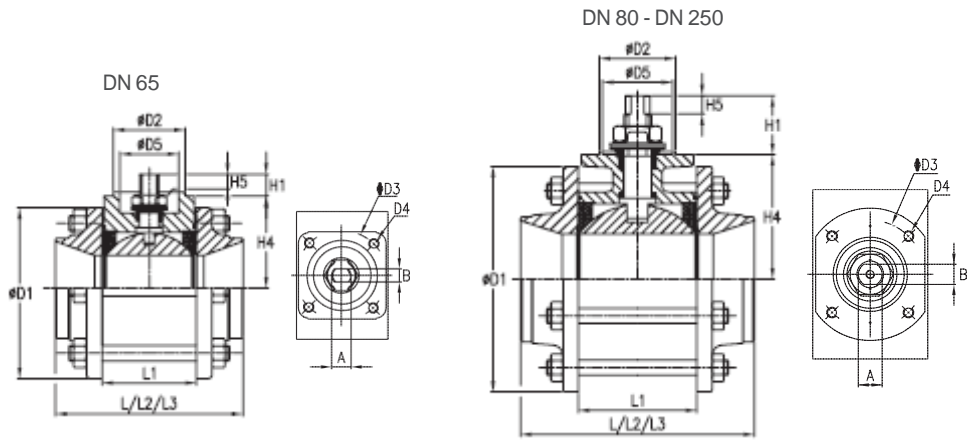

AVAILABLE END CONNECTION OPTIONS:

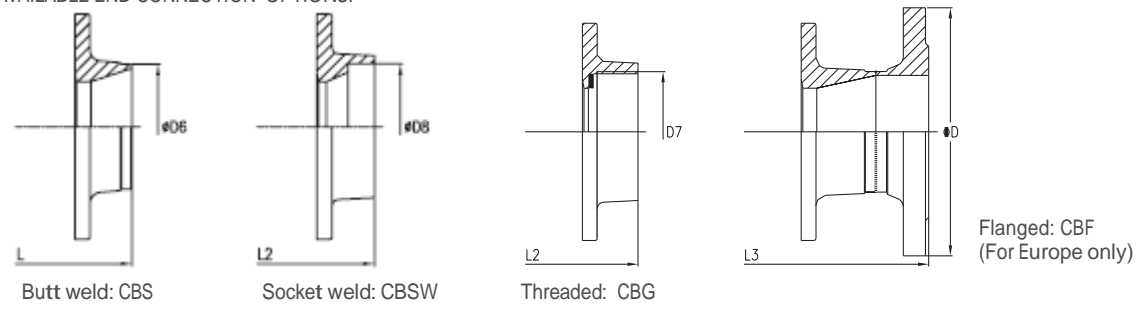

Approvals and Certificates

- TA-Luft according VDI 2440
- Fire tested according to EN ISO 10497-2010, API 607 5th Ed., wAPI 6FA 3rd Ed.
- Lloyds register type approval
- Tü.AGG and TÜV A type approval

CE PED module H up to category III

Dimensions (mm)

DN	ISO 5211	L3			øD								Weight (kg)										
		L	L1	L2	series 1	H1	H4	H5	PN16	øD1	øD2	øD3	D4	øD5	øD6	D7	øD8	A	B	Ball bore	CBS	CBSW	CBG
65	F07	142.6	71.4	160	290	16	70	16	185	143	55	70	M8	45	76.1	2 1/2"	77.0	18.0	12.0	50.0	6.6	6.8	16
80	F07	169.5	88.9	180	310	54	99	17	200	165	55	70	M8	45	88.9	3"	90.0	22.5	19.0	62.0	12.6	13.0	26
100	F10	214.0	108.5	214	350	54	114	17	220	206	70	102	M10	64	114.3	4"	115.5	22.5	19.0	82.4	23.0	23.0	34
125	F10	277.0	134.6	-	400	54	128	17	250	234	70	102	M10	64	139.7	-	-	22.5	19.0	100.0	37.0	-	47
150	F10	307.0	134.6	-	480	54	128	17	285	234	70	102	M10	64	168.3	-	-	22.5	19.0	100.0	40.0	-	56
200	F12	409.0	189.1	-	600	72	186	28	340	345	85	125	M12	65	219.1	-	-	35.0	28.5	150.0	84.0	-	133

Notes

All dimensions are related to reduced bore valves. For full bore valves please apply the dimensions of the next diameter (except L3, øD, øD6, D7 and øD8 which is identical in both instances)

Metal Seated

The metal sealing system and the graphite sealing systems are fully interchangeable with the standard PTFE systems for series RA ball valves. No further modifications to the valve body or ends pieces are required making these designs extremely versatile

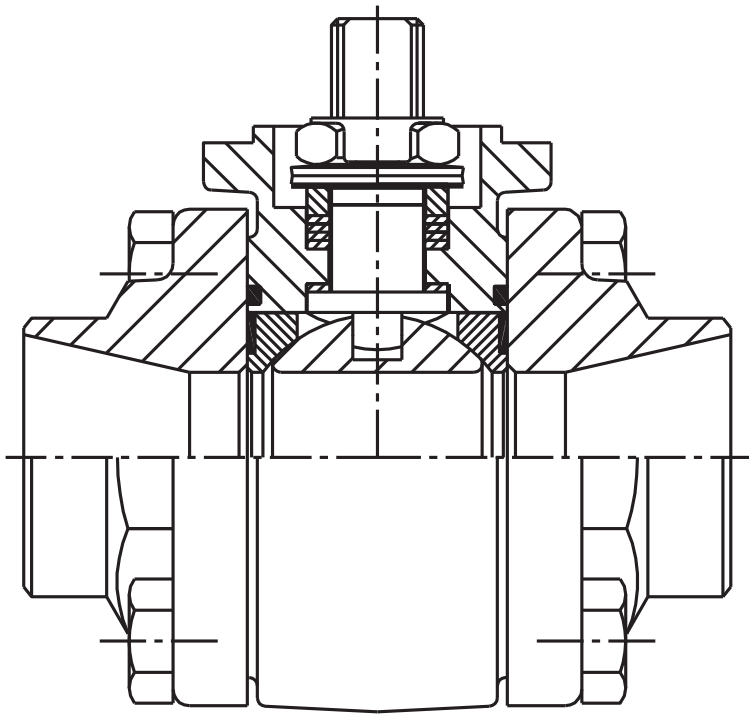

RA DN 40 with metal seats

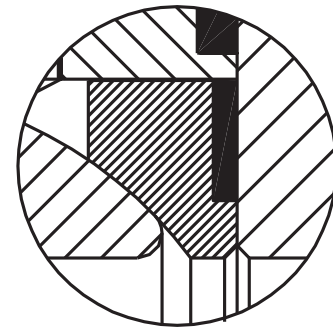

Metal seat type

Metal Sealing System

For the metal sealing system, Tungsten Carbides are sprayed at ultrasonic speeds, in cold condition, on the surfaces of the ball and seats. As no catalysts or additives are applied the surface layer is of a 100% homogeneous structure, resulting in optimum protection of the underlying materials. Seats and ball are then ground, polished and lapped for a perfect match. Ball and seats are a complete set. The seats are loaded with graphite Belleville washers ensuring a bi-directional tight shut off performance.

This unique, high-quality sealing system can be applied on all abrasive applications such as granulate transport, water glass, PTFE powder transport, pulp handling, polymerizing MMA, phosphate powder transport, sugar production, and wet steam.

3-piece ball valves

DN 20 - DN 100 full bore / DN 25 - DN 150 reduced bore
High temperature applications up to 400°C.



Technical Details

- For dimensional details refer to Series RA valves with carbon and metal sealing systems
- Stainless steel and carbon steel bodies
- Metal sealing system:
 - Titanium stabilized stainless steel ball and seats (DIN 1.4571)
 - Tungsten Carbide layers applied on ball and seat surfaces
 - Seats are axially compressed with graphite washers
 - Maximum temperature: 400°C (for higher temperatures contact your local KTM Mecafrance representative)
 - Maximum pressure rating: PN40 in function of temperature and valve size
- Bi-directional gas tight shut off performance due to optional lapping process
- Can be installed in standard KTM Mecafrance ball valves:
 - No modifications required
 - Excellent chemical and abrasion resistance
- The unique sealing system can be installed in all standard KTM Mecafrance 3 piece ball valves without modifying the end pieces or body. In this way standard PTFE seats can be replaced with this solution.

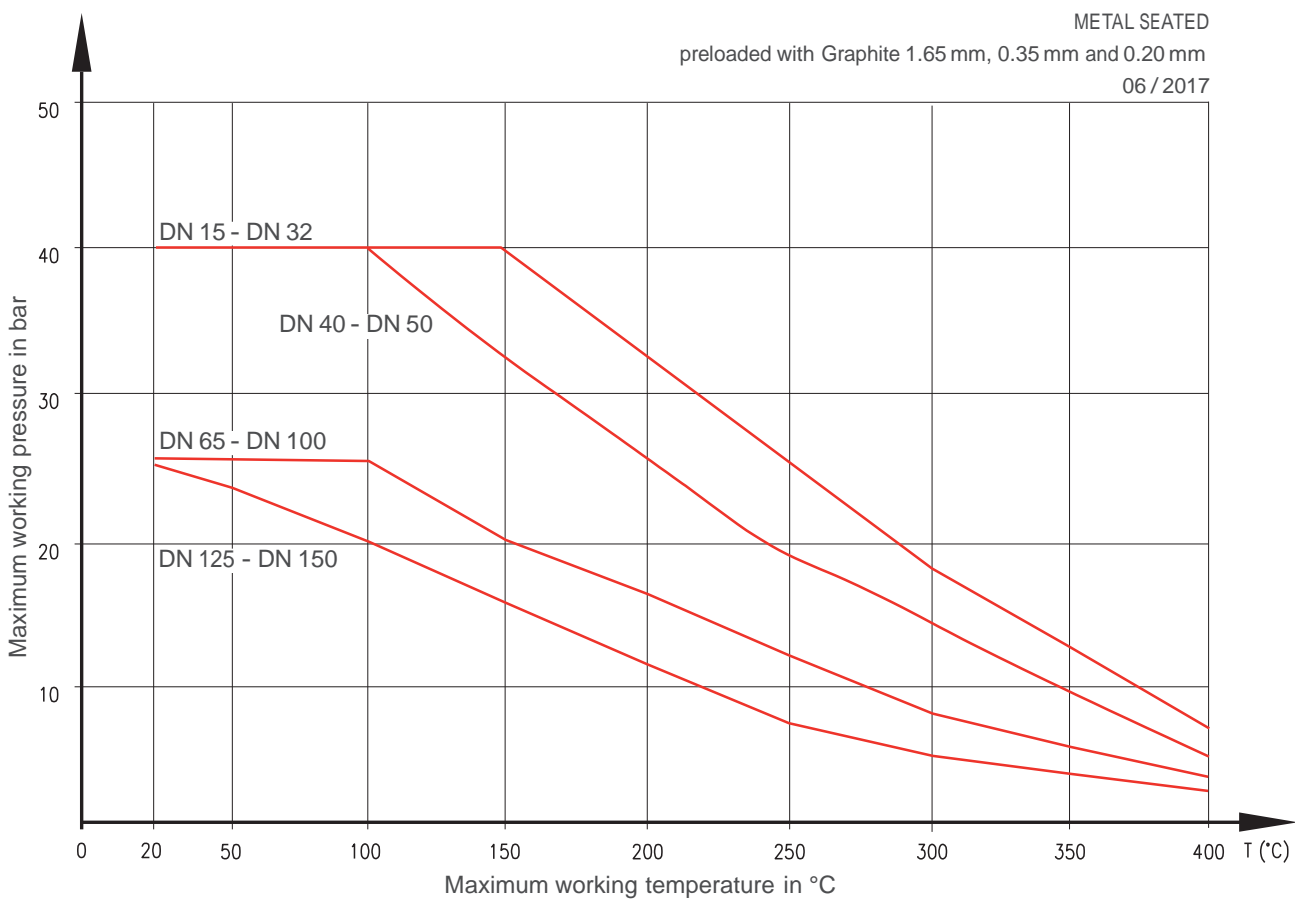

Notes

- * Full bore
- Please always verify maximum body ratings as each above mentioned diagram presents data for the seat material only
- For other material options, please contact

Cryogenic valves

DN 8 - DN 40 full bore

DN 15 - DN 50 reduced bore



3-piece ball valves with ISO top flange, series RA-Cryo
Butt weld, threaded, socket weld and flanged version.

RA 66 CYTC - DN 65

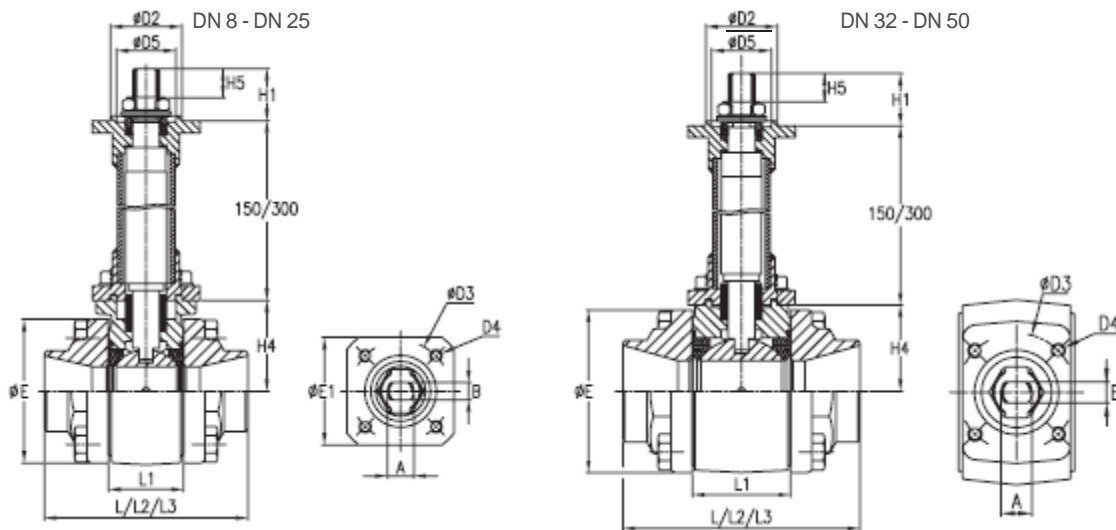

AVAILABLE END CONNECTION OPTIONS:

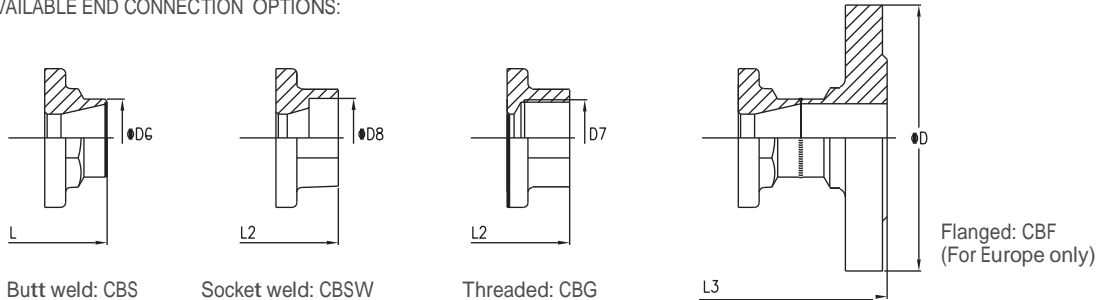

Design Features

- Reduced and full bore options available
- Stainless steel trim
- Forged end connections
- Integrated ISO 5211 top flange for easy automation
- Wide variety of seat material options available
- Temperature range: -196°C to +80°C
- Higher temperature available as an option using TFM4215 material.
- Pressure balancing hole in upstream side of the ball
- Scalloped seat design
- DN 15 - DN 65 in compliance with EN 1626 (on request)
- Cryo extensions to be mounted uniquely vertically
- Pressure rating: maximum PN100 in function of valve size and seat material selection
- Valve design according EN 13445
- Valves are degreased according EN 12300
- Valves are individually packed in polyethylene bags
- Size range: DN 15 - DN 150: RA version

Dimensions (mm)

DN	ISO 5211	L3																			
		L	L1	L2	series 1	H1	H4	H5	øE	øE1	øD	øD2	øD3	D4	øD5	øD6	D7	øD8	A	B	Ball bore
15	F03	65.0	20.4	65.0	130	10.5	30	7.0	45	45	95	25	36	M5	22	21.3	½"	21.8	9.5	5.4	11.1
20	F03	72.5	24.5	72.5	150	10.5	32	7.0	52	45	105	25	36	M5	22	26.9	¾"	27.4	9.5	5.4	14.2
25	F04	85.4	31.4	85.4	160	22.0	38	12.0	60	45	115	30	42	M5	25	33.7	1"	34.2	11.1	7.5	20.6
32	F04	99.3	41.3	99.3	180	22.0	36	12.0	68	45	140	30	42	M5	25	42.4	1¼"	43.0	11.1	7.5	25.4
40	F05	110.4	48.4	110.4	200	29.0	42	16.5	76	52	150	35	50	M6	30	48.3	1½"	49.0	14.3	8.9	31.7
50	F05	126.3	56.3	126.3	230	29.0	46	16.5	88	52	165	35	50	M6	30	60.3	2"	61.1	14.3	8.9	38.0

Notes

All dimensions are related to reduced bore valves. For full bore valves please apply the dimensions of the next diameter (except L3, øD, øD6, D7 and øD8 which is identical in both instances)

Cryogenic valves

DN 65 – DN 150



3-piece ball valves with ISO top flange, series RA-Cryo
Butt weld, threaded, socket weld and flanged version.

TF4215/TFM1600

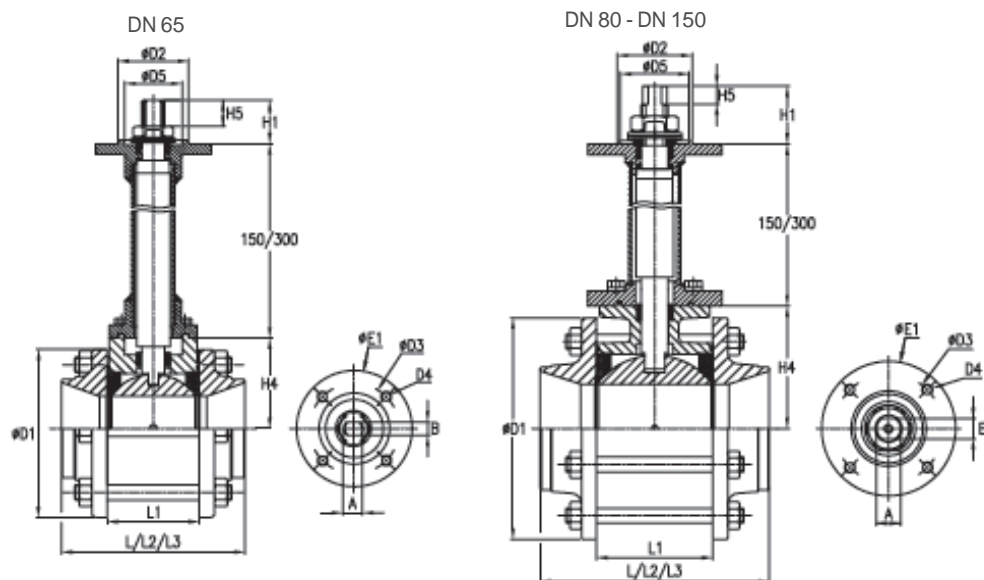

AVAILABLE END CONNECTION OPTIONS:

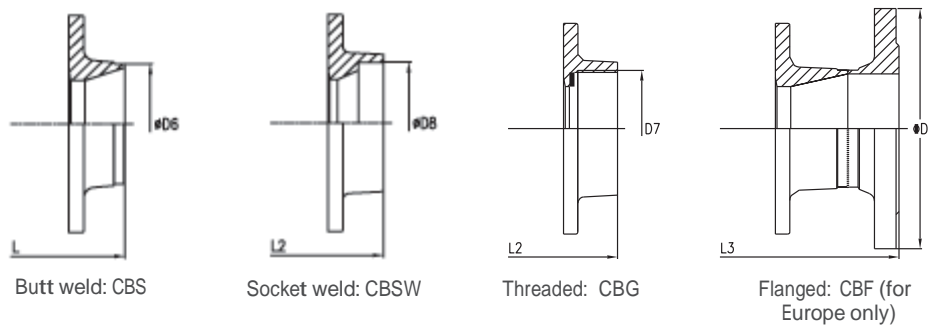

Approvals and Certificate

- TA-Luft according VDI 2440
- For 3-way valve version, please contact

CE PED module H up to category III

Dimensions (mm)

DN	ISO 5211	L		L3 series 1		H			øD		øD		øD		øD		øD		øD		Ball bore
		L	L1	L2	series 1	H1	H4	H5	øE1	PN16	øD1	øD2	øD3	D4	øD5	øD6	D7	øD8	A	B	
65	F07	142.6	71.4	160	290	35	70	21.5	90	185	143	55	70	M8	45	76.1	2½"	77.0	18.0	12	50.0
80	F07	169.5	88.9	180	310	54	99	28.0	76	200	165	55	70	M8	45	88.9	3"	90.0	22.5	19	62.0
100	F10	214.0	108.5	214	350	54	114	28.0	125	220	206	70	102	M10	64	114.3	4"	115.5	22.5	19	82.4
125	F10	277.0	134.6	-	400	54	128	28.0	125	250	234	70	102	M10	64	139.7	-	-	22.5	19	100.0
150	F10	307.0	134.6	-	480	54	128	28.0	125	285	234	70	102	M10	64	168.3	-	-	22.5	19	100.0

Notes

All dimensions are related to reduced bore valves. For full bore valves please apply the dimensions of the next diameter (except L3, øD, øD6, D7 and øD8 which is identical in both instances)

Spring return handle Dead man's lever



RA DN 25, butt weld with spring return handle

No.	Qty	Description
18	1	Lever
23	1	Lock washer
24	1	Stem nut
36	6	Screw

No.	Qty	Description
38	1	Spring
39	1	Lower part of housing
40	1	Upper part of housing
41	1	Control shaft

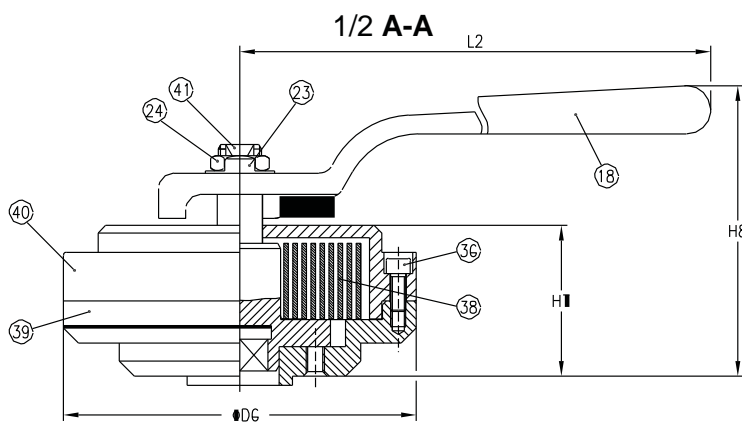

Type indication: BHM

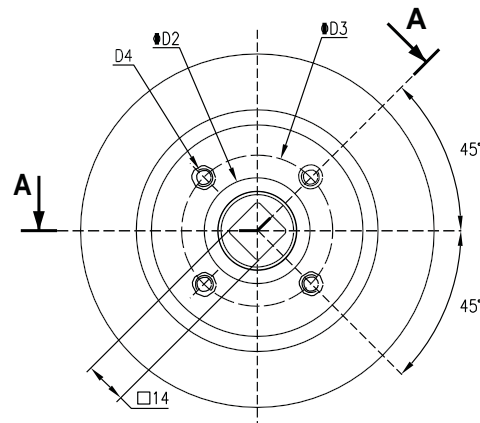

Connection details

Advantages

- The ISO interface enables the use of standard mounting kits
- The torque can be changed through a differentiated pre-tensioning of the spring. In this way, the KTM Mecafrance spring return handle can be used for different nominal diameters
- The double stop on the inside avoids the risk of injury and, through its form stability, it ensures that the switching radius of 90 is adhered to
- A grease filling in the housing prevents spring corrosion
- The compact closed housing rules out the possibility of any foreign particle infiltration, which could affect the function of the KTM Mecafrance spring return handle
- It can easily be assembled on Series RA KTM Mecafrance ball valves - even after valve is in service
- It can be used in either of the two switching positions, 'spring to close' or 'spring to open'
- The spring return handle must be operated fully open or fully closed. Intermediate positions can damage the seats and prevent proper operation of the spring return handle when returning to the original position so they must, therefore, be avoided.

Design features

- Action: spring-to-open, spring-to-close
- Double inside stop avoids risk of injury
- Maintenance free due to internal grease filling
- Compact, closed housing guaranteeing functionality
- To be mounted on RA valves
- ISO interface enabling standard mounting kits
- Maximum valve size: DN 50 reduced bore, and DN 40 full bore (TFM1600, PTFE or RTFE seats)

Applications

- Safety device
- Loading and unloading of dangerous media
- To avoid unintentional use of the valve
- All valves which are operated only for short period of time

Dimensions (mm)

RB DN	FB DN	ISO 5211	L2	øD2	øD3	D4	øD6	H7	H8	Md (Nm)		Weight (kg)
										Close	Open	
15	8-10	F05	200	35	50	M6	117	50	95	5	10	2.3
20	15	F05	200	35	50	M6	117	50	95	5	10	2.3
25	20	F05	200	35	50	M6	117	50	95	9	15	2.3
32	25	F05	250	35	50	M6	117	50	96	15	25	2.5
40	32	F05	250	35	50	M6	117	50	96	17	27	2.5
50	40	F05	250	35	50	M6	117	50	96	20	30	2.5

Manual operators

For Series RA

DN 15 - DN 65, high profile cast stainless steel handle with integrated locking device



For Series RA

DN 80 - DN 200, adjustable tube version stainless steel handle
(Option: bolt-on pad lock provision)



For Series RA

DN 15 - DN 50, stainless steel extension with bakelite balls, type RP
(Germany only)



For Series RA

DN 15 - DN 50, round carbon steel handwheel
(Germany only)

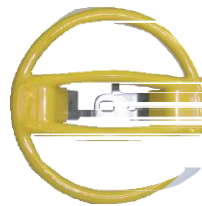

For Series RA

DN 15 - DN 50, oval carbon steel handwheel



For Series RA

DN 15 - DN 50, oval stainless steel handwheel



Approvals and Certification

KTM Mecafrance retains the following approvals and certificates

- Design to EN 13445 / EN 12516 / EN 10213
- Testing to EN 12266-1/2
- ISO 9001 (Development, construction, production, mounting and service)
- Deliveries according AD 2000 – A4
- TA-Luft according VDI 2440
- Type approval for transportation according EN14432/ 2014
Acceptance criteria: Dir 2010/35/EU
in compliance with ADR/RID 2017
- Type approval for cryogenic ball valves/
Standard ball valves: Dir 2010/35/EU in compliance with ADR/
RID and EN 1626: 2008
- Fire tested according to API 607 6th Edition 2010
- Certificate CU-TR 010 and CU-TR-032
- Declaration of compliance with regulation EN 1935/2004,
material and articles intended to come into contact with food
- Anti-Static according VGF
- Oxygen service according BAM VBG 62
- Safety integrity level (SIL) for use in safety related loops FMEDA
approved SIL level
- CE-certification by TÜV Rheinland: CE 0035 - Module H
- ISO 14001
- ISO 18001
- OHSAS 18001

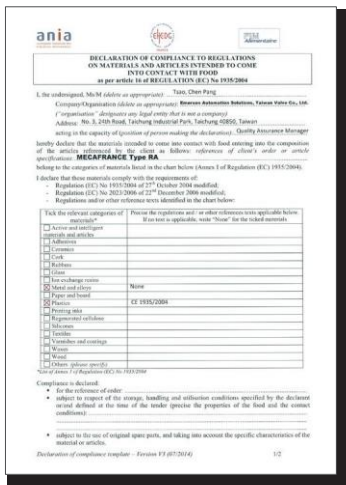



Tubi Valves Nederland BV

Tel. +31 (0)229 – 220 005

Fax. + 31 (0)229 – 220 021

Email. info@tubi-valves.com

www.tubi-valves.nl