

TOEPASSINGEN:

Perslucht, benzine, water, olie, gas, lage druk stoom

AANSLUITING: 1x binnendraad BSP volgens EN 10226-1
1x buitendraad BSP volgens EN 10226-1

BEDRIJFSOMSTANDIGHEDEN:

Druk: 25 bar

Temperatuur: 150°C

MATERIALEN:

N°	Omschrijving	Materialen
1	Huis	Messing MS 58
2	Zitting	PTFE
3	Kogel	Messing MS 58
4	Aansluitstuk	Messing MS 58
5	Pakking	PTFE
6	Pakkingdrukker	Messing MS 58
7	Moer	Staal
8	Spindel	Messing MS 58
9	Hendel	Staal

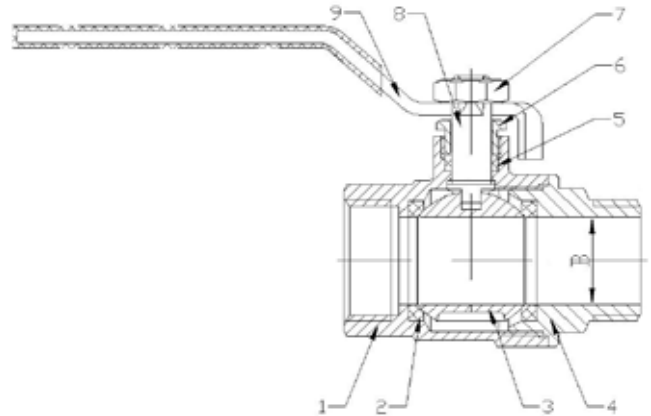

AFMETINGEN: (mm)

Ø	DN	L	H	D	PN	Kg
1/4"	8	51,5	42,0	81	25	0,55
3/8"	10	51,5	42,0	81	25	1,55
1/2"	15	55,5	47,0	87	25	2,55
3/4"	20	65,0	50,0	87	25	2,55
1"	25	73,0	57,0	126	25	3,55
1 1/4"	32	88,0	62,5	136	25	4,55
1 1/2"	40	99,5	77,5	160	25	5,55
2"	50	112,5	85,0	160	25	9,55
2 1/2"	65	143,5	132,0	240	25	13,55
3"	80	159,0	140,0	240	25	19,55
4"	100	195,0	153,0	270	25	29,55

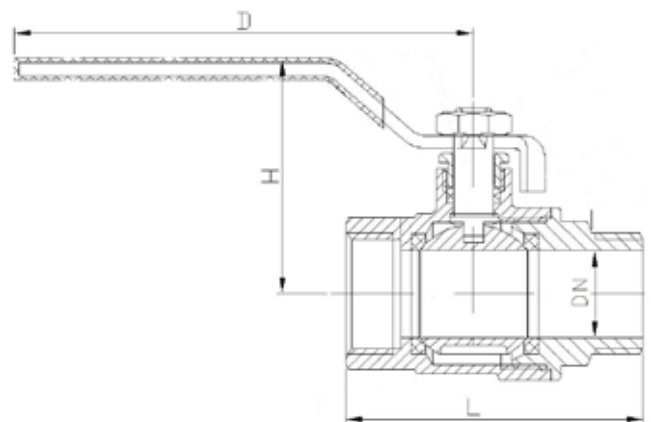

DRUK-TEMPERATUURDIAGRAMMA:

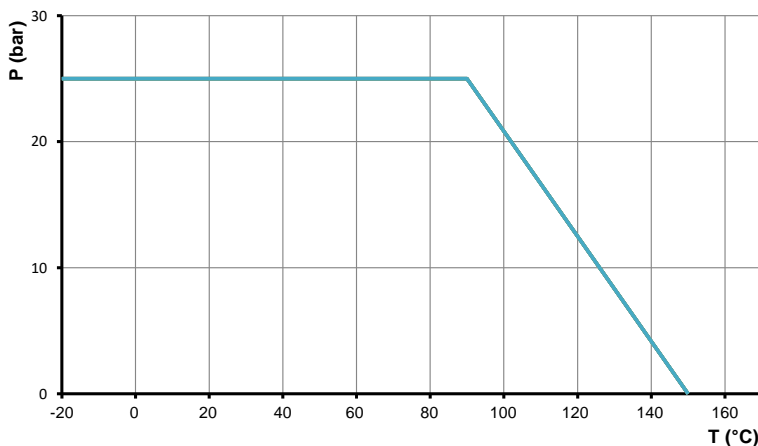

Wijzigingen voorbehouden