

ALGEMENE KENMERKEN:

- Tweedelig huis - vlottende kogel - volle doorlaat - niet-uitdrukbare spindel
- Inbouw lengte volgens DIN 3202 F18

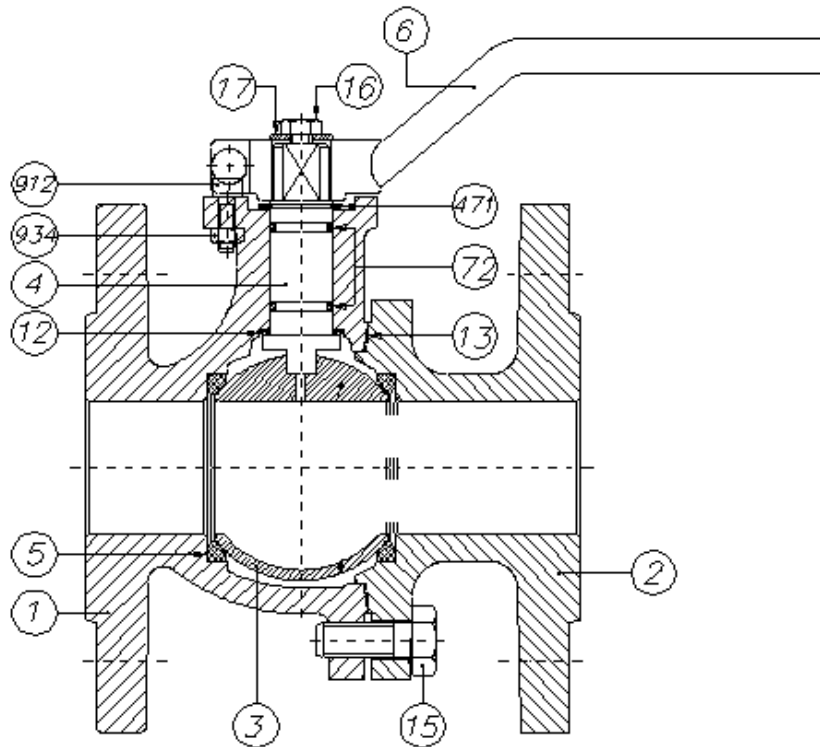

ONTWERP	
Kogelkraan	DIN 3357, EN 1983
Huis	DIN 3840
Flenzen	DIN 2501, EN 1092-1
Inbouw lengte	DIN 3202 F18, EN 558-1 Series 27
Opbouw flens	ISO 5211, DIN 3337
Markering	BS 5351, EN 19, CE-PED
TESTEN EN CERTIFICATEN	
Kwaliteit	ISO 9001, CE-PED
Druktest	DIN 3230, BS 6755 Part 1, EN 12266, NF E 29-203

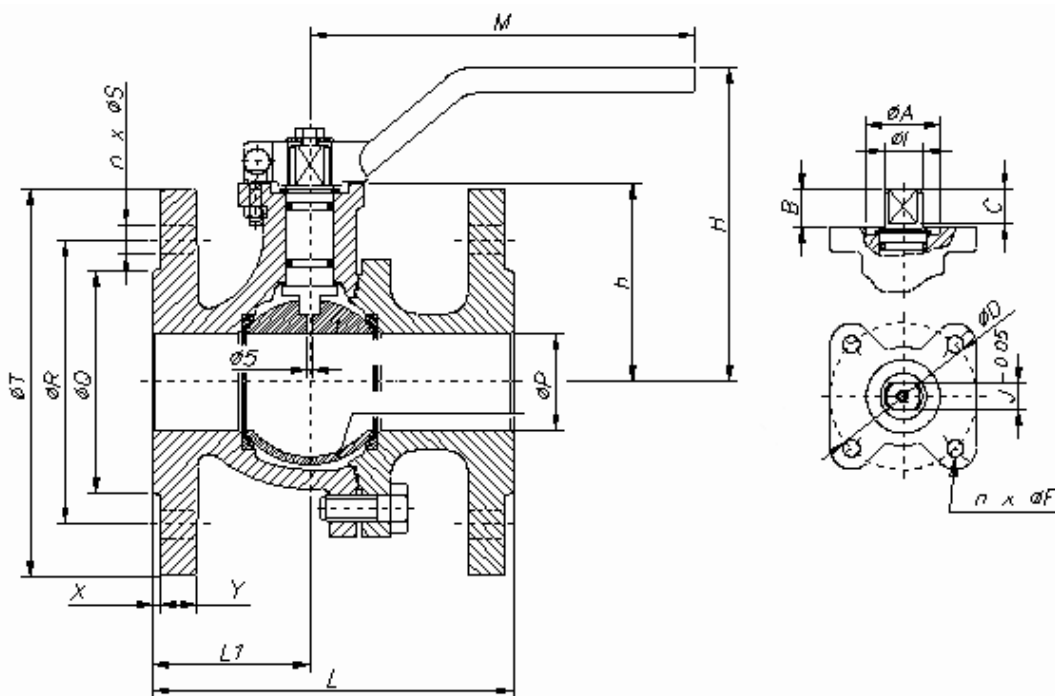

Pos.	Omschrijving	Materialen
1	Huis	EN-GJL-250
2	Aansluitflens	EN-GJL-250
3	Kogel	DN 15 ~ 25: AISI 303 DN 32 ~ 200: AISI 304
4	Spindel	AISI 304
5	Zitting	PTFE
6	Handel	Staal
12	Glijring	PTFE
13	Huisafdichting	PTFE
15	Bout (DN 32 t/m DN 100 tapeinden)	DIN 933 5.6
16	Bout	DIN 933 5.6
17	Rondel	Staal, verzinkt
72	O-ring	FKM
471	Rondel	DIN 471 staal
912	Bout	DIN 912 8.8
934	Moer	DIN 934 8

AFMETINGEN: (mm)

DN	Ø	Ø P	L	L1	Ø Q	Ø R	n x Ø S	Ø T	X	Y	h	M	H	Kg
15	1/2"	13	115	49,0	45	65	4x14	95	2	12	48,5	170,0	92,0	2,1
20	3/4"	17	120	55,5	58	75	4x14	105	2	14	53,0	170,0	95,5	2,7
25	1"	24	125	51,5	68	85	4x14	115	2	14	59,5	170,0	102,2	3,6
32	1 1/4"	31	130	53,0	78	100	4x18	140	2	14	72,0	170,0	114,7	5,3
40	1 1/2"	38	140	61,0	88	110	4x18	150	3	13	77,0	302,5	119,0	6,9
50	2"	50	150	62,0	102	125	4x18	165	3	15	85,0	302,5	127,0	9,0
65	2 1/2"	65	170	81,5	122	145	4x18	185	3	15	98,0	224,0	141,0	11,7
80	3"	80	180	79,0	138	160	8x18	200	3	17	108,5	335,0	151,5	14,7
100	4"	100	190	94,0	158	180	8x18	220	3	17	134,0	350,0	176,5	20,2
125	5"	125	325	120,5	188	210	8x18	250	3	19	165,0	350,0	208,0	33,7
150	6"	150	350	155,0	212	240	8x22	285	3	19	190,0	500,0	254,5	49,8
200	8"	200	400	190,0	268	295	12x22	340	3	21	229,0	500,0	293,5	81,8

OPBOUWFLENS: (mm)

DN	Ø	ISO	Ø A	B	C	Ø D	n x F	Ø I	J	Kg
15	1/2"	F04	19	7,5	5,5	42	4x5	10	7	2,0
20	3/4"	F04	19	6,0	5,0	42	4x5	10	7	2,6
25	1"	F04	21	6,2	5,0	42	4x5	10	7	3,5
32	1 1/4"	F04	21	6,7	5,5	42	4x5	10	7	5,2
40	1 1/2"	F04	30	15,0	16,0	42	4x5	16	12	6,5
50	2"	F04	30	15,0	16,0	42	4x5	16	12	8,6
65	2 1/2"	F07	35	18,0	19,0	70	4x8	18	13	11,0
80	3"	F07	35	18,0	19,0	70	4x8	18	13	14,0
100	4"	F07	38	19,0	20,0	70	4x8	22	16	19,5
125	5"	F07	38	19,5	20,0	70	4x8	22	16	33,0
150	6"	F10	50	24,5	27,0	102	4x10	28	20	47,5
200	8"	F10	50	24,5	27,0	102	4x10	28	20	79,5

Wijzigingen voorbehouden

DRUK-TEMPERATUURDIAGRAMMA:

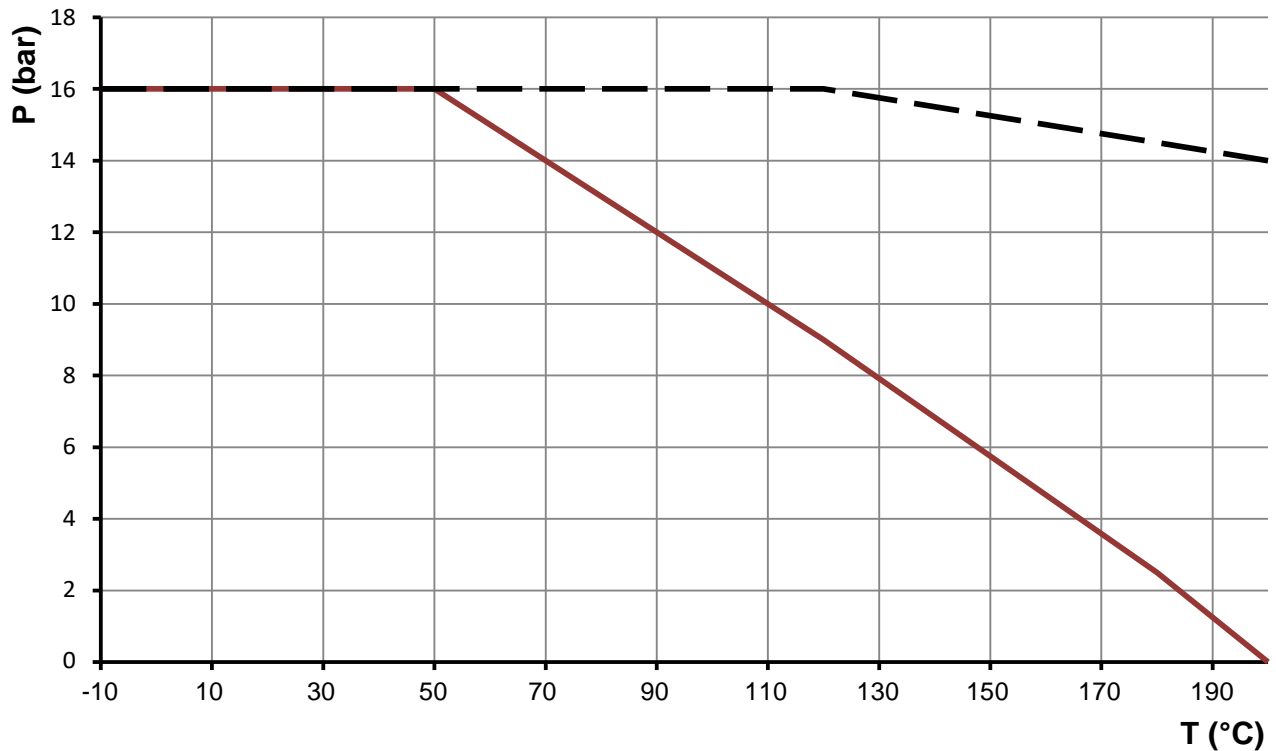

DRAAIMOMENT: (Nm) Kv-WAARDE: (m³/h)

DN	Verschildruk	
	16 bar	Kv-waarde
15	6	37,4
20	6	74,8
25	11	105,0
32	12	176,0
40	26	223,0
50	41	416,0
65	41	660,0
80	71	1.200,0
100	119	1.980,0
125	190	3.600,0
150	220	5.040,0
200	450	10.890,0