

ALGEMENE KENMERKEN:

- Tweedelig huis - vlottende kogel - volle doorlaat - niet-uitdrukbaar spindel
- Anti-static device volgens BS 5351, ISO 7121 en NF E29-470
- Drukvereffeningsboring (standaard= 5 mm) in de bovenzijde van de kogel voorkomt overdruk in de ruimte tussen de kogel en het huis
- Alle afsluiters voldoen aan de TA Lüft-vereisten
- DIN 3357 en Fire Safe
- Max. temperaturen: -29°C ~ 230°C (AIT) en -50°C ~ 230°C (IIT)

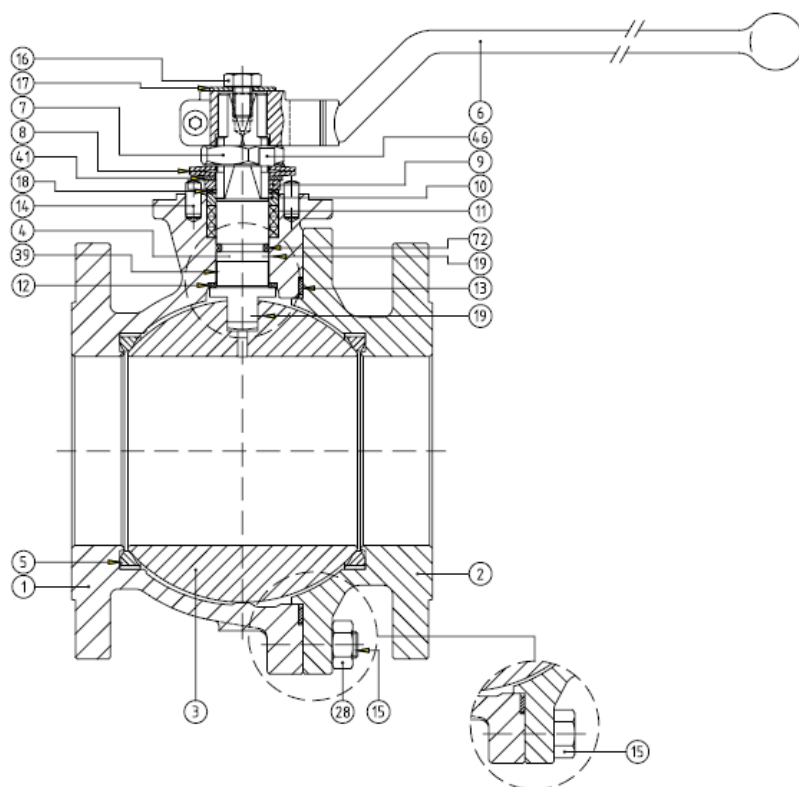

ONTWERP	
Kogelkraan	DIN 3357, EN 1983
Huis	DIN 3840
Laagdikte	BS 5351
Flenzen	DIN 2501, EN 1092-1
Inbouw lengte	DIN 3202 F18, EN 558-1 Series 27
Opbouw flens	ISO 5211, DIN 3337
Afwerking beschermlaag	MSS SP 55
Markering	BS 5351, EN 19, CE-PED
TESTEN EN CERTIFICATEN	
Kwaliteit	ISO 9001, CE-PED
Fire Safe certificaten	BS 6755 Part 2, ISO 10497: 2004
Druktest	DIN 3230, BS 6755 Part 1, EN 12266, NF E 29-203
Andere	ISO 14001, ATEX

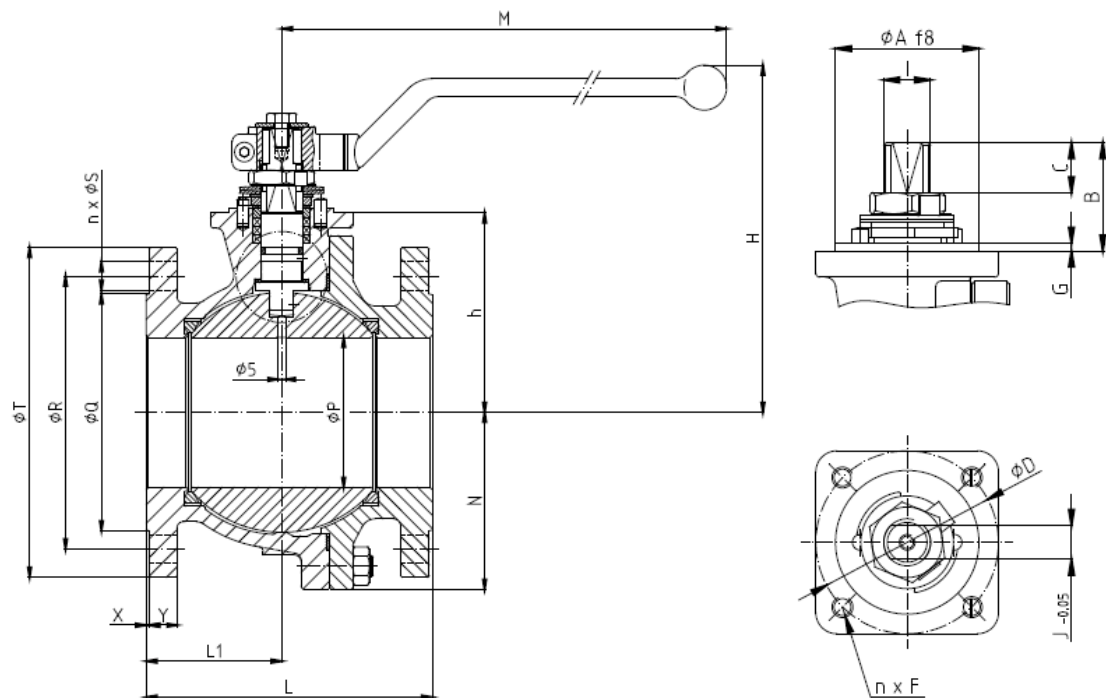

Pos.	Omschrijving	Materialen	
		AIT	IIT
1	Huis	1.0619	1.4408
2	Aansluitflens	1.0619	1.4408
3	Kogel	A 351 Gr. CF8M (DN 15 : 25 A 479 Tp.316)	
4	Spindel	A 479 Tp.316	
5	Zitting	PTFE	
6	Handel	Nodulair gietijzer	
7	Spindelmoer	Staal, verzinkt	AISI 303
8	Schotelveer	Staal	Staal, vernikkeld
9	Stopplaat	Staal	AISI 304
10	Pakkingdrukker	AISI 303	AISI 316
11	Pakking	Grafiet	
12	Glijring	25% G.F. PTFE	
13	Huisafdichting	AISI 316L + PTFE + grafiet	
14	Stop	Staal	Roestvaststaal
15	Bout (DN 32 t/m DN 100 tapeinden)	DIN 933 Gr.8.8	DIN 933 A4-70
16	Bout	DIN 933 A4-70	
17	Rondel	Staal, verzinkt	AISI 304
18	Rondel	25% G.F. PTFE	
19	Antistatic device	Roestvaststaal	
28	Moer (DN 32 t/m DN 100)	DIN 934 Gr.8	DIN 934 A4-70
39	Spindelgeleiding (DN 25 t/m DN 200)	25% G.F. PTFE	
41	Rondel (DN 40 t/m DN 200)	Staal	AISI 304
46	Rondel	AISI 304	
72	O-ring	FKM	

AFMETINGEN: (in mm)

DN	Ø P	L	L1	Ø Q	Ø R	n x Ø S	Ø T	X	Y	h	N	H	M	Kg
15	15	115	53	45	65	4x14	95	2	14	46	-	110	164	3
20	20	120	52	58	75	4x14	105	2	16	53	-	117	164	3
25	25	125	49	68	85	4x14	115	2	16	58	-	129	164	5
32	32	130	54	80	100	4x18	140	2	16	67	-	131	210	7
40	40	140	55	88	110	4x18	150	3	15	76	-	148	213	9
50	50	150	61	102	125	4x18	165	3	17	84	-	155	213	12
65	65	170	76	122	145	4x18	185	3	15	97	-	169	348	16
80	80	180	82	138	160	8x18	200	3	17	111	-	207	445	22
100	100	190	90	158	180	8x18	220	3	17	133	118	231	495	32
125	125	325	120	188	210	8x18	250	3	19	156	138	262	698	53
150	151	350	135	212	240	8x22	285	3	19	183	160	298	698	76
200	203	400	200	268	295	12x22	340	3	21	233	208	352	868	111

OPBOUWFLENS: (in mm)

DN	ISO	Ø A	B	C	Ø D	n x F	G	I	J
15	F05	35	11,2	5,7	50	4x M6	1,5	M12x1.5	9
20	F05	35	13,2	9,2	50	4x M6	1,5	M12x1.5	9
25	F05	35	22,7	10,2	50	4x M6	1,5	M12x1.5	9
32	F05	35	32,0	13,7	50	4x M6	1,5	M16x1.5	12
40	F07	55	41,5	19,2	70	4x M8	3,0	M18x1.5	13
50	F07	55	41,5	19,2	70	4x M8	3,0	M18x1.5	13
65	F07	55	44,0	19,7	70	4x M8	3,0	M22x1.5	16
80	F10	70	44,5	19,7	102	4x M10	3,0	M25x1.5	18
100	F10	70	56,5	29,2	102	4x M10	3,0	M28x1.5	20
125	F12	85	56,0	27,6	125	4x M12	3,0	M35x2	25
150	F12	85	68,0	38,5	125	4x M12	3,0	M40x2	29
200	F14	100	72,0	39,0	140	4x M16	4,0	M45x2	32

Wijzigingen voorbehouden

DRUK-TEMPERATUURDIAGRAMMA:

AIT

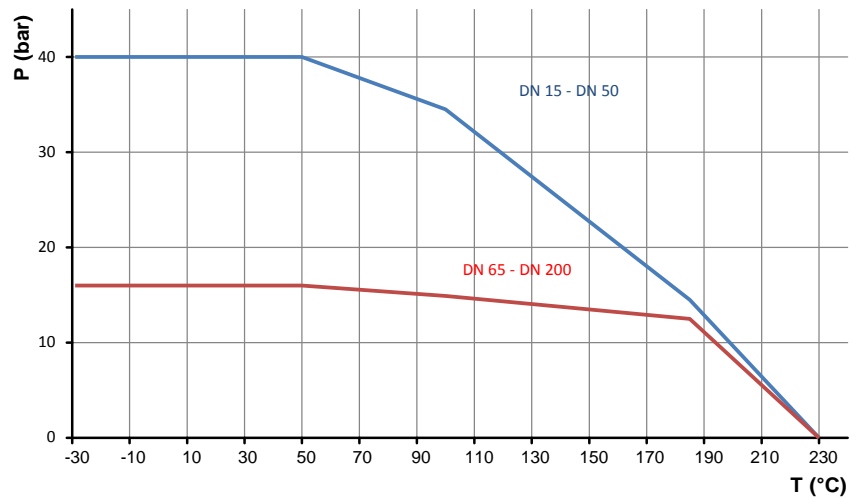

IIT

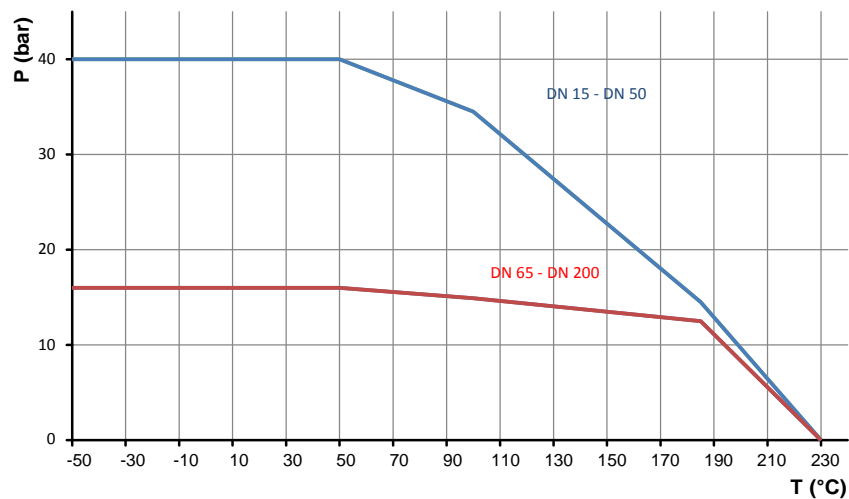
DRAAIMOMENT: (in Nm)

DN	Verschildruk	
	16 bar	40 bar
15	8	10
20	10	14
25	15	16
32	22	25
40	25	30
50	40	55
65	55	-
80	85	-
100	130	-
125	180	-
150	250	-
200	580	-

Kv-WAARDE: (in m³/h)

DN	Kv-waarde
15	20
20	40
25	75
32	130
40	170
50	270
65	550
80	1.000
100	1.650
125	3.000
150	4.200
200	9.000

Wijzigingen voorbehouden