

TOEPASSINGEN:

Perslucht, benzine, water, olie, lage druk stoom

AANSLUITING: BSP volgens EN 10226-1

MATERIALEN:

N°	Omschrijving	Materialen
1/4	Huis	CW617N, vernikkeld
2	Zittingen	PTFE
3	Kogel	CW617N, verchromd
5	Spindel	CW617N, vernikkeld
6	Drukkring	CW617N, vernikkeld
7	Moer	C84FF, Geomet® gecoat
8	Spindelafdichting	PTFE
9	Slijtring	PTFE
10	Hendel	DD11 Geomet® met zwarte PVC sleeve

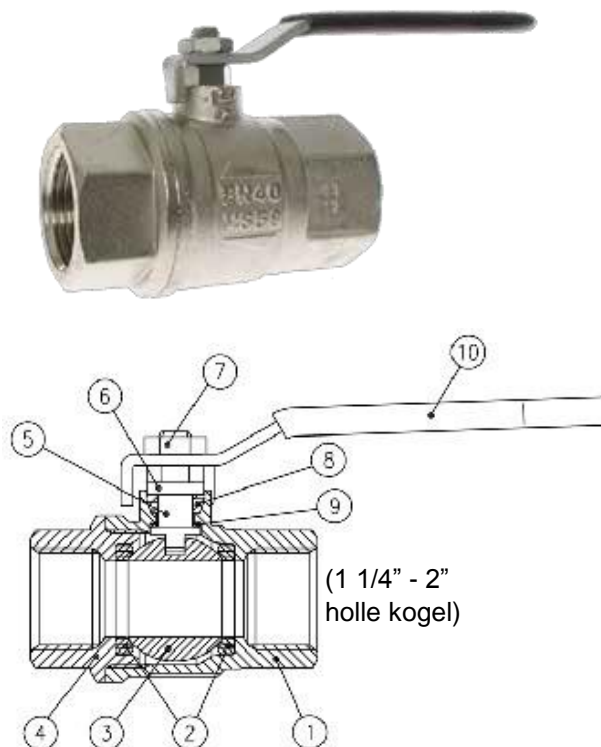

AFMETINGEN: (mm)

Ø	DN	L	A	H	PN	Kg
1/4"	8	51,0	82	39,5	65	0,19
3/8"	10	51,0	82	39,5	65	0,17
1/2"	15	61,0	100	43,0	65	0,27
3/4"	20	74,5	120	52,5	40	0,45
1"	25	90,5	120	57,0	40	0,80
1 1/4"	32	104,0	158	78,0	40	1,09
1 1/2"	40	117,0	158	85,0	40	1,54
2"	50	135,0	158	92,0	40	2,45

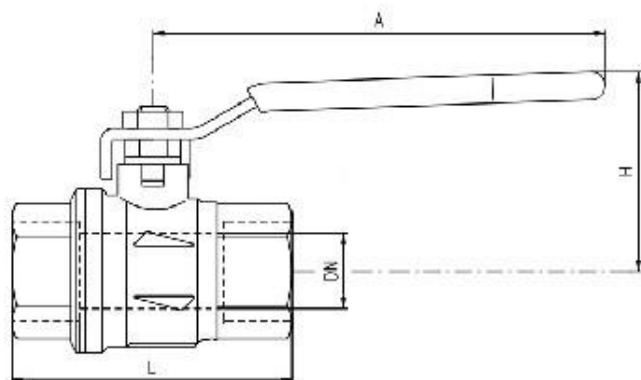

DRUK-TEMPERATUURDIAGRAMMA:

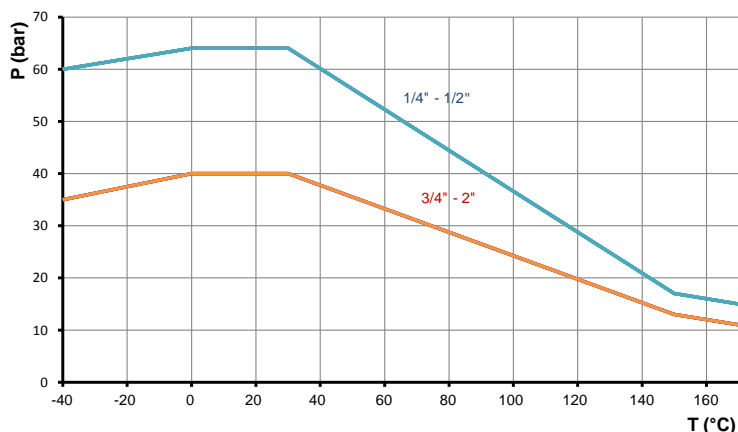

OP AANVRAAG:

- met locking device (Fig. 33H)
- met vleugelmoer (Fig. 33VM)

ijzigingen voorbehouden