



Size : DN 15 to 150 mm
Ends : Between flanges PN16 R.F.
Min Temperature : -20°C
Max Temperature : + 180°C
Max Pressure : 16 Bars
Specifications : ISO 5211 mounting pad
PTFE filled with glass seat
Anti blow-out stem

Materials : Stainless steel

SPECIFICATIONS :

- Full bore
- Anti blow-out stem
- PTFE filled with glass stem
- ISO 5211 mounting pad
- Threaded holes flanges
- Hollow body
- Locking device from DN 25 to DN 100

USE :

- Chemical and pharmaceutical industries, petrochemical industries, hydraulic installation, compressed air
- Min and max Temperature Ts : -20°C to + 180°C
- Max Pressure Ps : 16 bars (see graph)

PRESSURE / TEMPERATURE GRAPH (STEAM EXCLUDED) :

**PRESSURE
BAR**

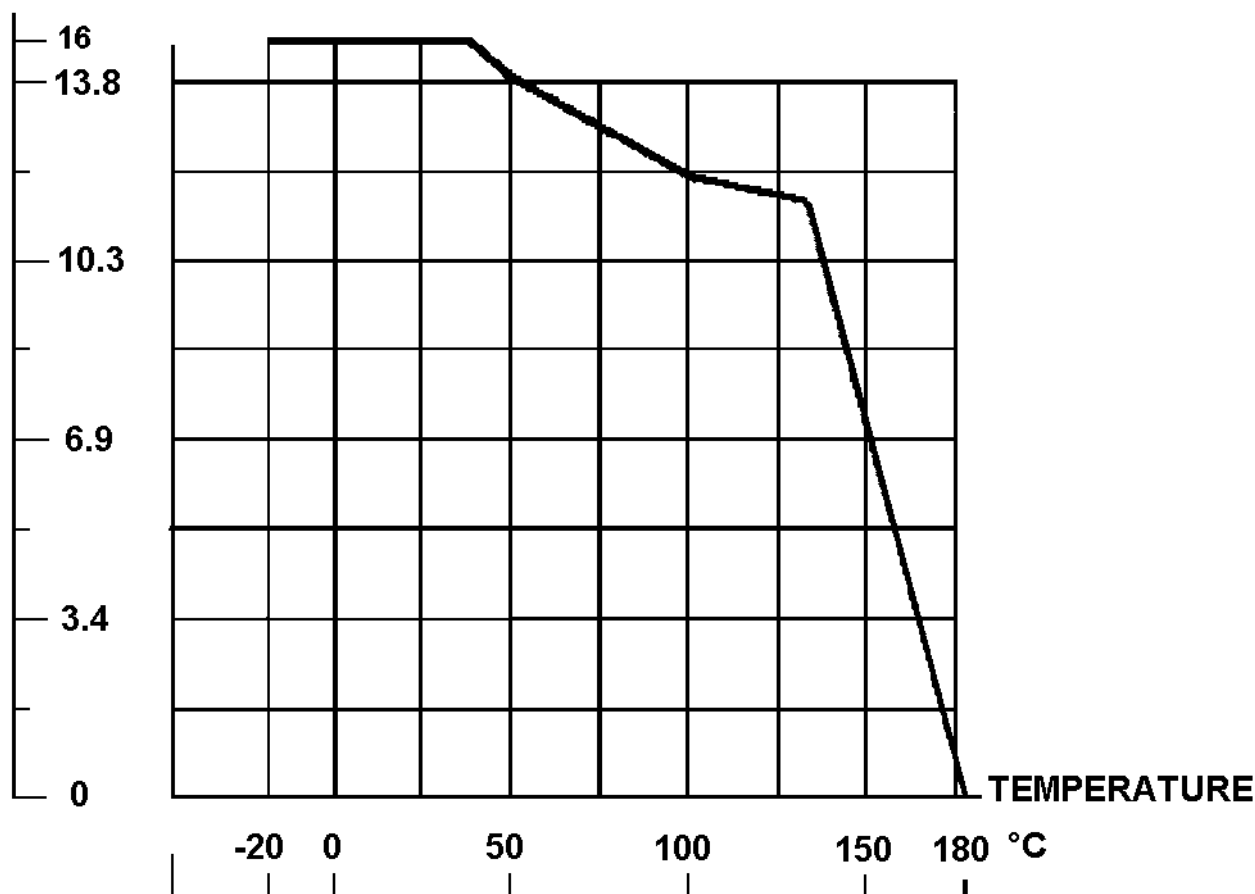

RANGE :

- Stainless steel body from DN 15 to DN 150

ENDS :

- Between flanges PN16 R.F.

MATERIALS DN 15 - 20 :

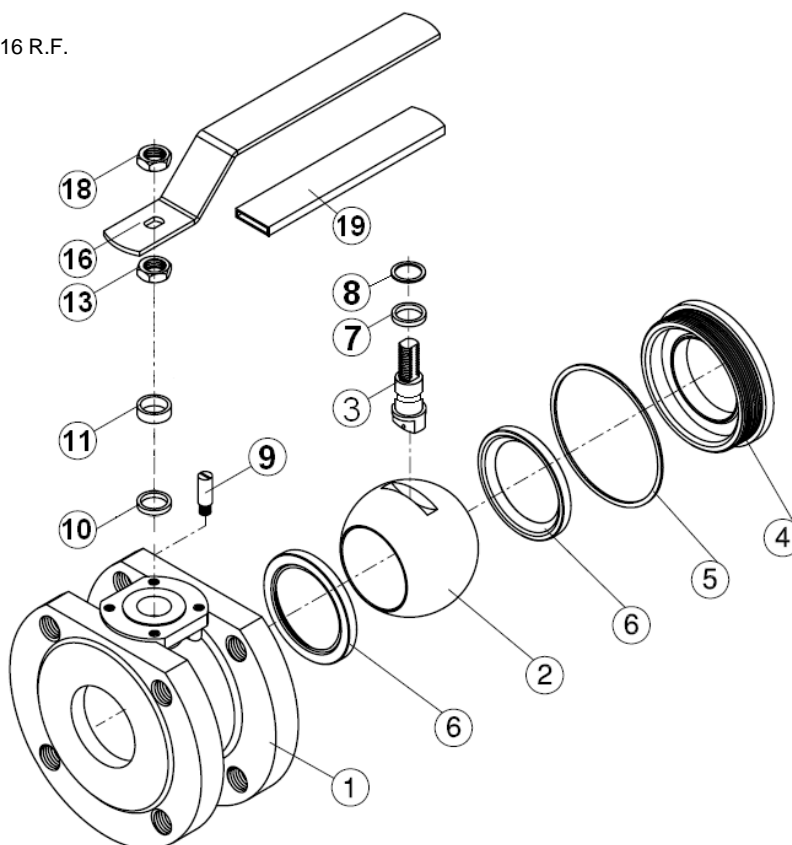

Item	Designation	Materials
1	Body	ASTM A351 CF8M
2	Ball	ASTM A351 CF8M
3	Stem	SS 304
4	Insert	ASTM A351 CF8M
5*	Body seal	PTFE
6*	Seat	PTFE filled with 3% glass
7*	Thrust washer	PTFE
8*	O ring	FKM
9	Stop pin	SS 304
10*	Packing	PTFE
11	Gland	SS 304
13	Gland nut	SS 304
16	Handle	SS 304
18	Handle nut	SS 304
19	Handle cover	Plastic

(* : Included in gaskets kit)

MATERIALS DN 25 - 50 :

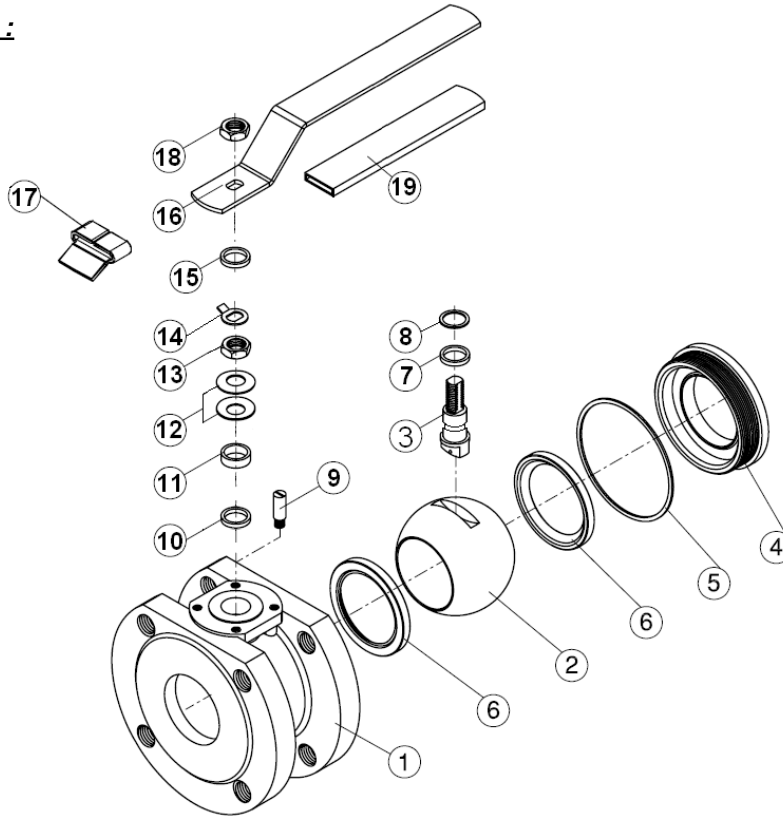

Item	Designation	Materials
1	Body	ASTM A351 CF8M
2	Ball	ASTM A351 CF8M
3	Stem	SS 304
4	Insert	ASTM A351 CF8M
5*	Body seal	PTFE
6*	Seat	PTFE filled with 3% glass
7*	Thrust washer	PTFE
8*	O ring	FKM
9	Stop pin	SS 304
10*	Packing	PTFE
11	Gland	SS 304
12	Elastic ring	SS 301
13	Gland nut	SS 304
14	Tab washer	SS 304
15	Washer	SS 304
16	Handle	SS 304
17	Locking device	SS 304
18	Handle nut	SS 304
19	Handle cover	Plastic

(* : Included in gaskets kit)

MATERIALS DN 65 - 100 :

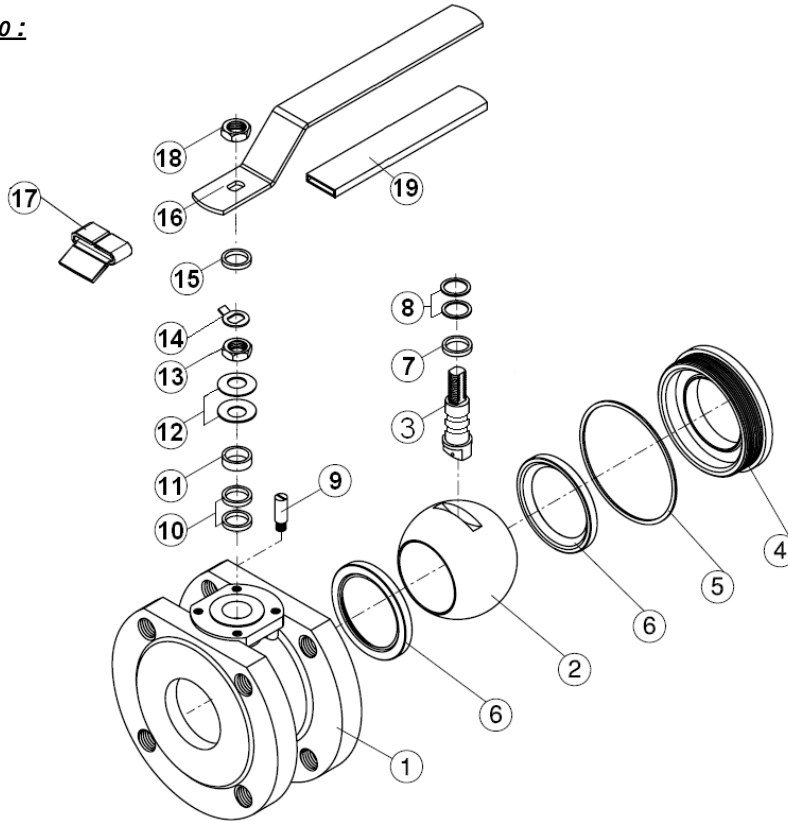

Item	Designation	Materials
1	Body	ASTM A351 CF8M
2	Ball	ASTM A351 CF8M
3	Stem	SS 304
4	Insert	ASTM A351 CF8M
5*	Body seal	PTFE
6*	Seat	PTFE filled with 3% glass
7*	Thrust washer	PTFE
8*	O ring	FKM
9	Stop pin	SS 304
10*	Packing	PTFE
11	Gland	SS 304
12	Elastic ring	SS 301
13	Packing	SS 304
14	Tab washer	SS 304
15	Washer	SS 304
16	Handle	SS 304
17	Locking device	SS 304
18	Handle nut	SS 304
19	Handle cover	Plastic

(* : Included in gaskets kit)

MATERIALS DN 125 - 150 :

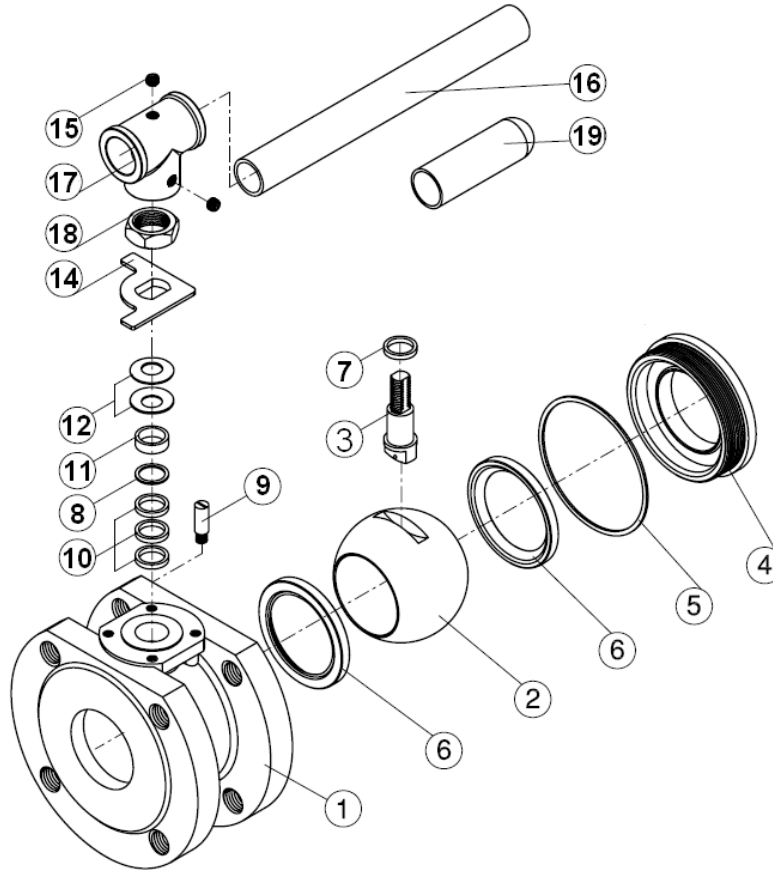

Item	Designation	Materials
1	Body	ASTM A351 CF8M
2	Ball	ASTM A351 CF8M
3	Stem	SS 316
4	Insert	ASTM A351 CF8M
5*	Body seal	PTFE
6*	Seat	PTFE filled with 15% glass
7*	Thrust washer	PTFE
8*	Packing	PTFE
9	Stop pin	SS 304
10*	Stem packing	PTFE
11	Gland	SS 304
12	Elastic ring	SS 301
14	Stop plate	SS 304
15	Handle screw	SS 304
16	Handle	Steel
17	Handle adapter	ASTM A351 CF8
18	Packing nut	SS 304
19	Handle cover	Plastic

(* : Included in gaskets kit)

SIZE (in mm):

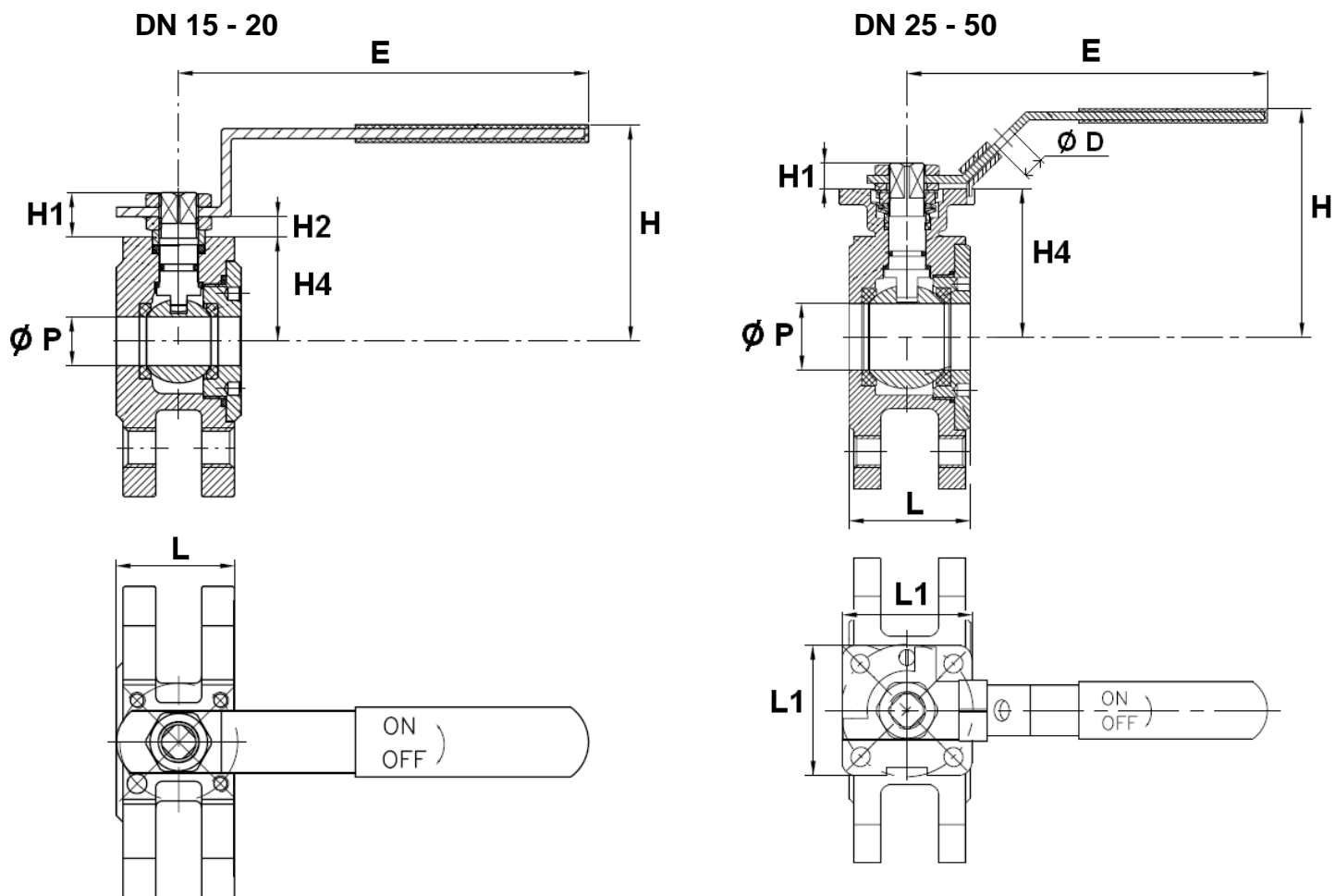

Ref.	DN	15	20	25	32	40	50
	Ø P	15	20	25	32	38	50
	L	35	39	44	52	64	83
	L1	-	-	49	49	65	65
	E	125.2	125.2	136.2	136.2	204.5	204.5
	H	75	80	95	101.5	122.5	121.5
	H1	13.5	13.5	12	10	13.5	14
	H2	6	6	-	-	-	-
	H4	32	35.5	65	71.5	85	83.5
	Ø D	-	-	8	8	8	8
	Weight (Kg)	1.1	1.41	1.82	3	4.3	5.9

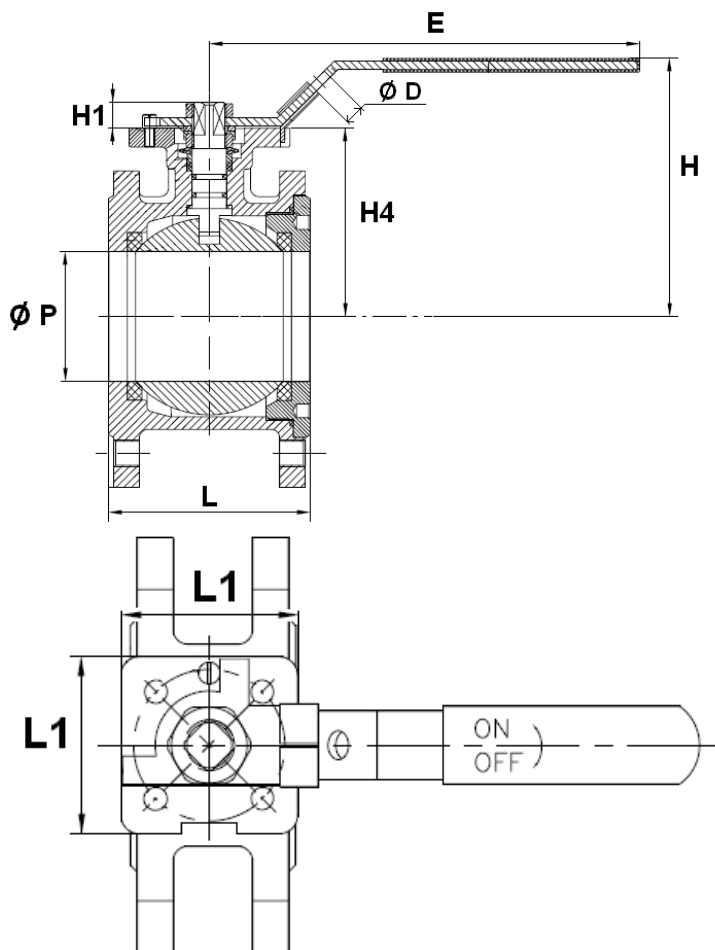
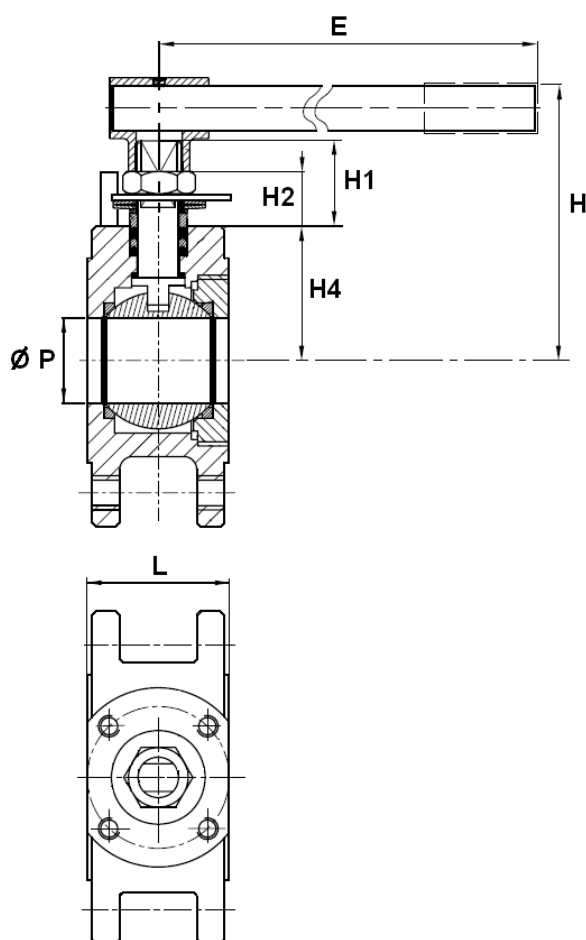
SIZE (in mm):
DN 65 - 100

DN 125 - 150

Ref.	DN	65	80	100	125	150
	Ø P	65	76	94	118	135
	L	100	121	152	179	202
	L1	94	94	94	-	-
	E	250	250	320	400	600
	H	142	161	174	205	220
	H1	18	18	20.5	50	50
	H2	-	-	-	31	31
	H4	101	120	130	117	130
	Ø D	10	10	10	-	-
	Weight (Kg)	9	12.5	19.4	30	41

ISO MOUNTING PAD AND STEM SIZE (in mm) :

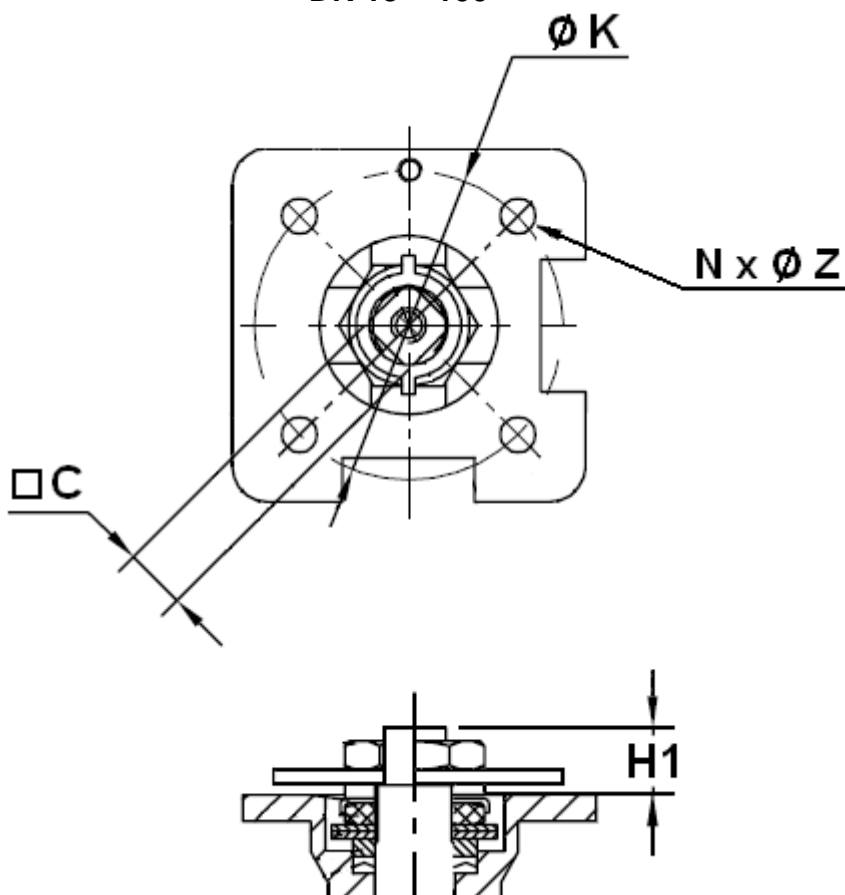
DN 15 – 100



DN 125 - 150

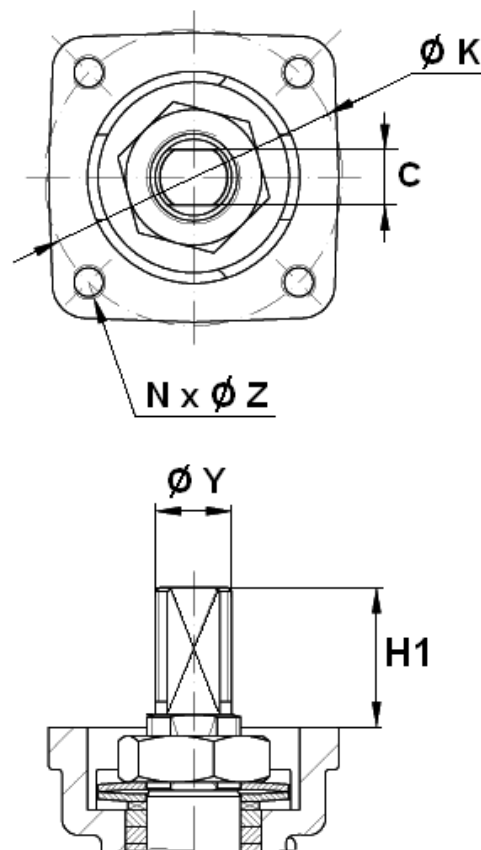

DN	15	20	25	32	40	50	65	80	100	125	150
C	9	9	11	11	14	14	17	17	17	17	17
Ø Y	-	-	-	-	-	-	-	-	-	28	28
H1	13.5	13.5	12	10	13.5	14	18	18	20.5	50	50
Ø K	36	36	42	42	50	50	70	70	102	102	125
ISO	F03	F03	F04	F04	F05	F05	F07	F07	F10	F10	F12
N x Ø Z	4 x 5	4 x 5	4 x 6.4	4 x 6.4	4 x 7	4 x 7	4 x 9	4 x 9	4 x 11	4 x M10	4 x M12

SIZE THREADED FLANGES HOLES (FOR PN16 FLANGES in mm):

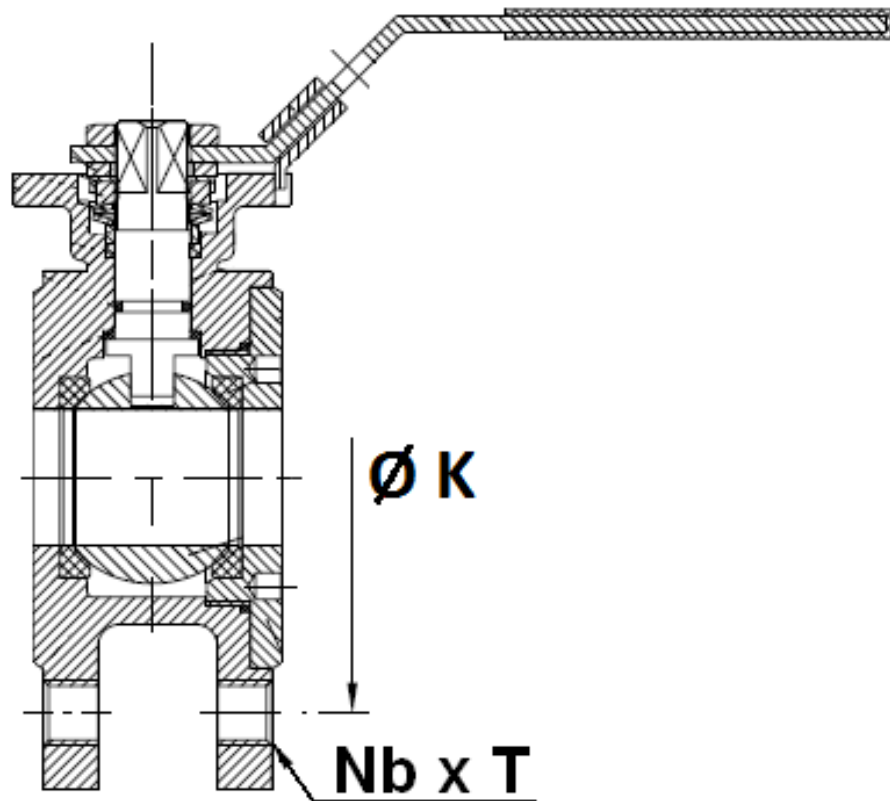

DN	15	20	25	32	40	50	65	80	100	125	150
Ø K	65	75	85	100	110	125	145	160	180	210	240
Nb x Ø L	4 x M12	4 x M12	4 x M12	4 x M16	4 x M16	4 x M16	4 x M16	8 x M16	8 x M16	8 x M16	8 x M20

TORQUE VALUES (in Nm without safety coefficient) :

DN	15	20	25	32	40	50	65	80	100	125	150
Torque (Nm)	7	9	13	19	27	40	60	85	150	190	250

STANDARDS :

- Fabrication according to ISO 9001 : 2008
- DIRECTIVE 97/23/CE : CE N° 0035
Risk Category II Module D1
- Construction according to EN 12516
- Designing according to ASME B16.34
- Pressure tests according to EN 12266-1, Range A
- ISO 5211 mounting pad
- PN16 R.F. flanges according to EN 1092-1 PN16
- Length according to EN 558 series 100 up to DN100

ADVICE : Our opinion and our advice are not guaranteed and Tubi Valves shall not be liable for the consequences of damages.
The customer must check the right choice of the products with the real service conditions.

INSTALLATION INSTRUCTIONS

GENERAL GUIDELINES :

- Ensure that the valves to be used are appropriate for the conditions of the installation (type of fluid, pressure and temperature).
- Be sure to have enough valves to be able to isolate the sections of piping as well as the appropriate equipment for maintenance and repair.
- Ensure that the valves to be installed are of correct strength to be able to support the capacity of their usage.
- **Installation of all circuits should ensure that their function can be automatically tested on a regular basis (at least two times a year).**

INSTALLATION INSTRUCTIONS :

- **Before installing the valves, clean and remove any objects from the pipes** (in particular bits of sealing and metal) which could obstruct and block the valves.
- **Ensure that both connecting pipes either side of the valve (upstream and downstream) are aligned (if they're not, the valves may not work correctly).**
- **Make sure that the two sections of the pipe (upstream and downstream) match, the valve unit will not absorb any gaps. Any distortions in the pipes may affect the tightness of the connection, the working of the valve and can even cause a rupture. To be sure, place the kit in position to ensure the assembling will work.**
- **If sections of piping do not have their final support in place, they should be temporarily fixed. This is to avoid unnecessary strain on the valve.**
- Tighten the bolts in cross.
- It's recommended to operate the valve (open and close) 1 to 2 times per year