

ALGEMENE KENMERKEN:

- Kogelkraan met volle doorlaat in staal, DN 10 - DN 100
- Voor tussenbouw tussen flenzen PN 16/40 (DN 10 - DN 50), PN 16 (DN 65 - DN 100)
- Met getapte gaten volgens DIN 2501
- Anti-static device
- Niet-uitdrukbare spindel
- Fire safe volgens EN ISO 10497 en API 607
- Opbouwflens volgens ISO 5211, DIN 3337

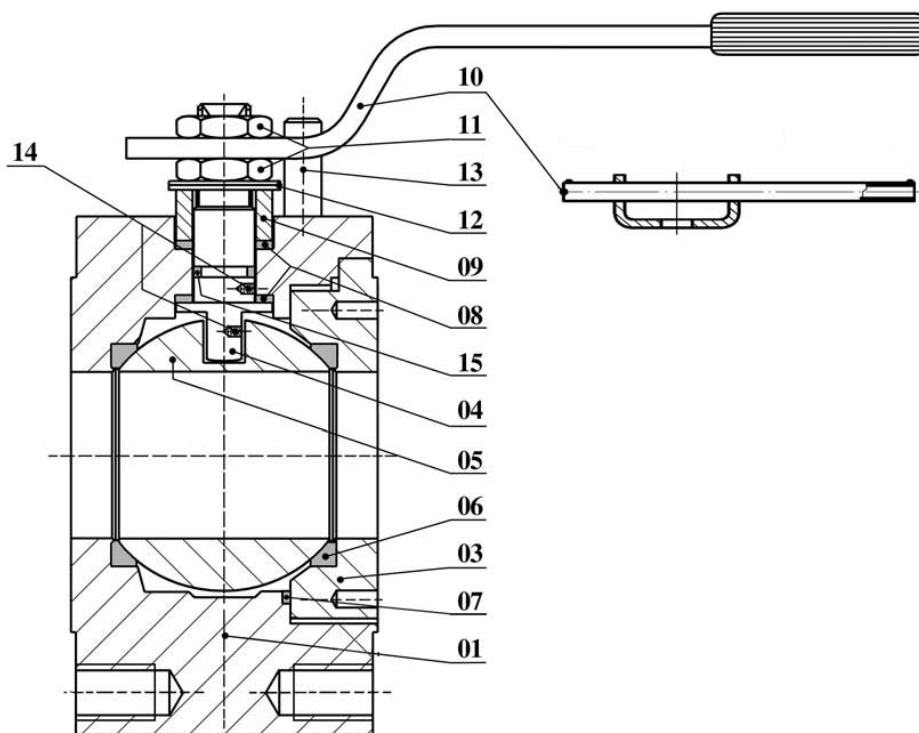

ONTWERP	
Flenzen	DIN 2501, EN 1092-1
Opbouwflens	ISO 5211, DIN 3337
Markering	EN 19, CE-PED
TESTEN EN CERTIFICATEN	
Kwaliteit	ISO 9001, CE-PED
Fire Safe certificaten	EN ISO 10497: 2004, API 607
Druktest	EN 12266
Andere	ATEX: II 2 GD c T6 X, TA Lüft



Pos.	Omschrijving	Materialen
1	Huis	ASTMA105
3	Tegenflens	ASTMA105
4	Spindel	AISI 410
5	Kogel	ASTMA479 F304
6	Zitting	PTFE
7	Huisafdichting	PTFE + grafiet
8	Spindelafdichting	PTFE + grafiet
9	Stopbuspakking	CF9SMnPb36 UNI 4838, verzinkt
10	Hendel	Fe37 UNI 7070, verzinkt
11	Moer en tegenmoer	6S UNI 3740, verzinkt
12	Schotelveren	50CrV4 UNI 3545, verzinkt
13	Stop	8.8 UNI 3740, verzinkt
14	Antistatic device	ASTMA182 F304
15	O-ring op de spindel	Viton

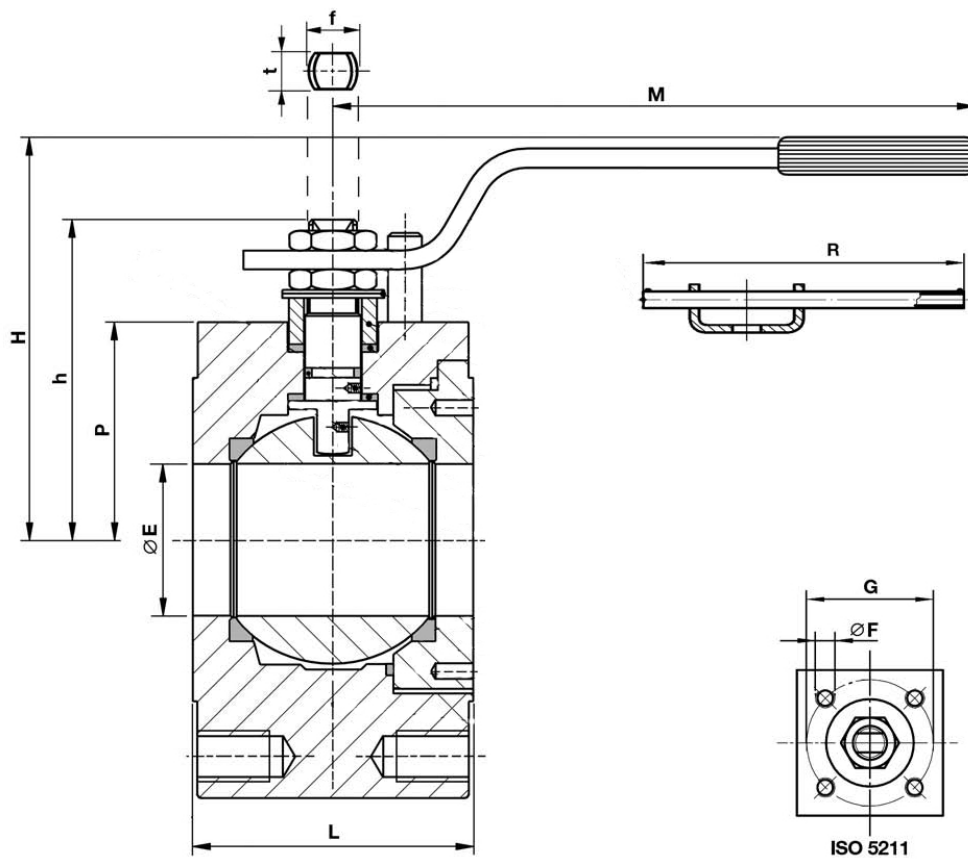

AFMETINGEN: (mm)

DN	Ø	ØE	L	M	R	H	h	P	f	t	ISO 5211	ØF	G	kg
10	3/8"	14	36	150	-	84	52	33,0	10	6	F03	M5	36	1,5
15	1/2"	14	36	150	-	84	52	33,0	10	6	F03	M5	36	1,5
20	3/4"	19	39	150	-	87	54	36,0	10	6	F03	M5	36	2,0
25	1"	24	43	185	-	95	69	43,0	12	8	F03	M5	36	2,7
32	1 1/4"	29	51	185	-	99	72	48,0	12	8	F03	M5	36	4,0
40	1 1/2"	38	63	275	-	118	95	63,0	16	10	F05	M6	50	6,5
50	2"	48	83	275	-	126	101	68,5	16	10	F05	M6	50	10,0
50X*	2"	48	70	275	-	126	101	68,5	16	10	F05	M6	50	9,0
65	2 1/2"	64	107	380	-	143	122	82,0	22	14	F07	M8	70	17,0
80	3"	76	120	380	-	149	127	88,5	22	14	F07	M8	70	20,5
100X*	4"	95	140	440	500	185	151	101,5	30	18	F10	M10	102	33,0

*: op aanvraag

DRUK-TEMPERATUURDIAGRAMMA:

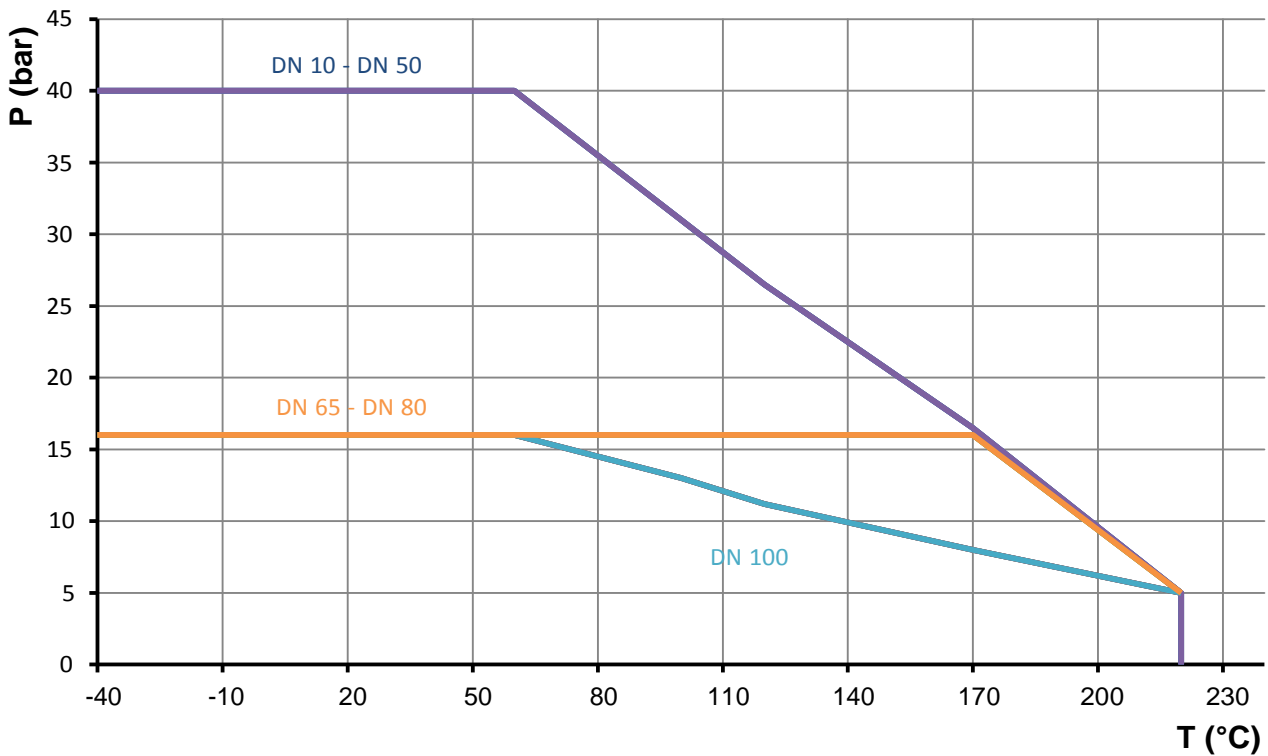

DRAAIMOMENT: (Nm)

DN	Verschildruk	
	16 bar	40 bar
10	4	5
15	7	9
20	9	13
25	13	17
32	15	21
40	28	39
50	36	50
50X	36	50
65	64	-
80	77	-
100X	127	-