

### Overview

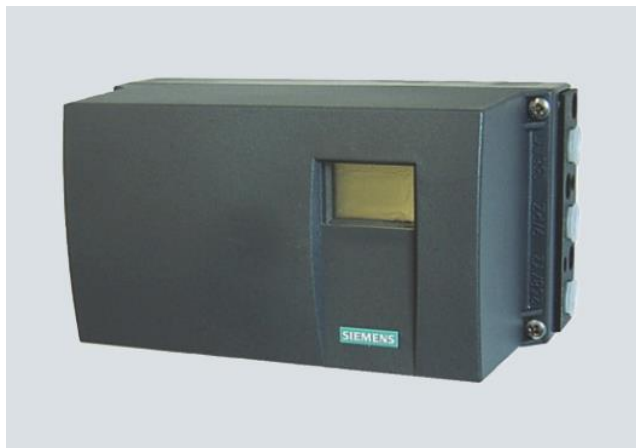

Electropneumatic positioner SIPART PS2 in the Makrolon enclosure



SIPART PS2 Ex d electropneumatic positioner in flameproof aluminium enclosure (Ex d)

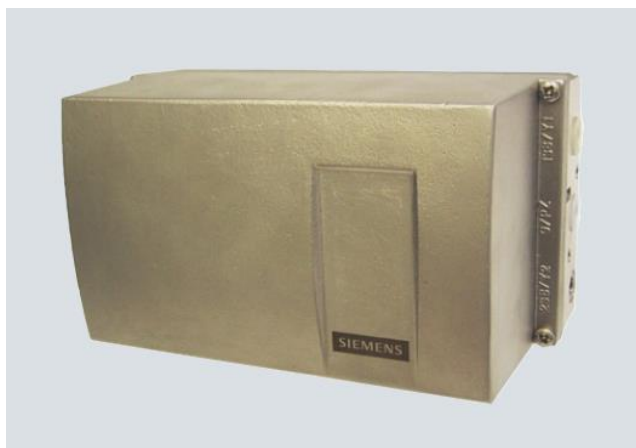

SIPART PS2 in stainless steel enclosure

The SIPART PS2 electropneumatic positioner is used to control the final control element of pneumatic linear or part-turn actuators. The electropneumatic positioner moves the actuator to a valve position corresponding to the setpoint. Additional function inputs can be used to block the valve or to set a safety position. A binary input is present as standard in the basic device for this purpose.

### Benefits

SIPART PS2 positioners offer decisive advantages:

- Simple installation and automatic commissioning (self-adjustment of zero and span)
- Simple operation with
  - Local operation (manual operation) and configuration of the device using three buttons and a user-friendly two-line display
  - Parameterization via SIMATIC PDM
- Very high-quality control thanks to an online adaptation procedure
- Negligible air consumption in stationary operation
- "Tight shut-off" function (ensures maximum positioning pressure on the valve seat)
- Numerous functions can be activated by simple configuring (e. g. characteristic curves and limits)
- Extensive diagnostic functions for valve and actuator
- Only one device version for linear and part-turn actuators
- Few moving parts, hence insensitive to vibrations
- External non-contacting position sensor as option for extreme ambient conditions
- "Intelligent solenoid valve": Partial Stroke Test and solenoid valve function in a single device
- Partial Stroke Test e. g. for safety valves
- Can also be operated with purified natural gas, carbon dioxide, nitrogen or noble gases
- SIL (Safety Integrity Level) 2

### Application

The SIPART PS2 positioner is used, for example, in the following industries:

- Chemical/petrochemical
- Power stations
- Paper and glass
- Water, waste water
- Food and pharmaceuticals
- Offshore plants

The SIPART PS2 positioner is available:

- For single-acting actuators: In Makrolon, stainless steel or aluminium enclosure, as well as flameproof aluminium enclosure (Ex d)
- For double-acting actuators: In Makrolon enclosure, stainless steel enclosure and flameproof aluminium enclosure (Ex d)
- For non-hazardous applications
- For hazardous applications in the versions
  - Type of protection intrinsic safety "Ex i"
  - Type of protection flameproof enclosure "Ex d" in flameproof aluminium enclosure
  - Type of protection non-sparking "Ex nA", energy-limited "Ex nL", dust protection via enclosure "Ex tD"

and in the versions:

- With 0/4 ... 20 mA control with/without communication through HART signal
- With PROFIBUS PA communication interface
- With Foundation Fieldbus (FF) communications interface.

### Explosion-proof versions

The device is available in the following versions for use in atmospheres subject to explosion hazards:

- Flameproof design for use in zone 1 and class I, division 1
- Intrinsically safe design for use in zone 1 and class I, division 1
- Non-sparking and energy-limited design for use in zone 2 and class I, division 2
- Dust-protected design for use in zone 22
- Dust-protected design for use in class II, division 1 and 2 and class III

### Stainless steel enclosure for extreme ambient conditions

The SIPART PS2 is available in a stainless steel enclosure (with no window in the cover) for use in particularly aggressive environments (e.g. offshore operation, chlorine plants etc.). The device functions are the same as for the basic version.

### Design

The SIPART PS2 positioner is a digital field device with a highly-integrated microcontroller.

The positioner consists of the following components:

- Enclosure and cover
- PCB with corresponding electronics with or without communication through HART or with electronics for communication in accordance with - PROFIBUS PA specification, IEC 61158-2; bus-supplied device, or - Foundation Fieldbus (FF) specification, IEC 61158-2, bus-supplied device
- Position detection system
- Terminal housing with screw terminals
- Pneumatic valve manifold with piezoelectric valve precontrol.

The valve manifold is located in the housing, the pneumatic connections for the inlet air and the positioning pressure on the right-hand side. A pressure gauge block and/or a safety solenoid valve can be connected there as options. The SIPART PS2 positioner is fitted to the linear or part-turn actuator using an appropriate mounting kit. The circuit board container in the casing provides slots for separately ordered boards with the following functions:

#### I y module

- Position feedback as a two-wire signal 4 to 20 mA

#### Alarm unit (3 outputs, 1 input)

- Signaling of two limits of the travel or angle by binary signals. The two limits can be set independently as maximum or minimum values.
- Output of an alarm if the setpoint position of the final control element is not reached in automatic mode or if a device fault occurs.
- Second binary input for alarm signals of for triggering safety reactions, e.g. blocking function or safety position.

#### Limit signaling through slot-type initiators (SIA module)

Two limits can be signaled redundantly as NAMUR signals (EN 60947-5-6) by slot-type initiators. An alarm output is also integrated in the module (see "Alarm Module").

### Limit value signal via mechanical contacts (limit value contact module)

Two limits can be signaled redundantly by switching contacts. An alarm output is also integrated in the module (see "Alarm Module").

Valid for all modules described above:

All signals are electrically isolated from one another and from the basic unit. The outputs indicate self-signaling faults. The modules are easy to retrofit.

### Separate mounting of positioner detection system and controller unit

The position detection system and controller unit can be connected separately for all casing versions of the SIPART PS2 (except flameproof design). Measurement of the travel or angle is carried out directly on the actuator. The controller unit can then be fitted a certain distance away, e.g. on a mounting pipe or similar, and is connected to the position detection system by an electric cable and to the actuator by one or two pneumatic lines. Such a split design is frequently advantageous if the ambient conditions at the fitting exceed the specified values for the positioner (e.g. strong vibrations).

The following can be used for measuring the travel or angle:

- NCS sensor
- External position detection system C73451-A430-D78
- A commercially available potentiometer (10 kΩ resistance), e.g. for higher application temperatures or customer-specific applications

The use of potentiometers is recommended for very small linear actuators with a short valve travel since, on the one hand, the space required by the potentiometer is very small and, on the other, the transmission characteristic is optimum for a small travel.

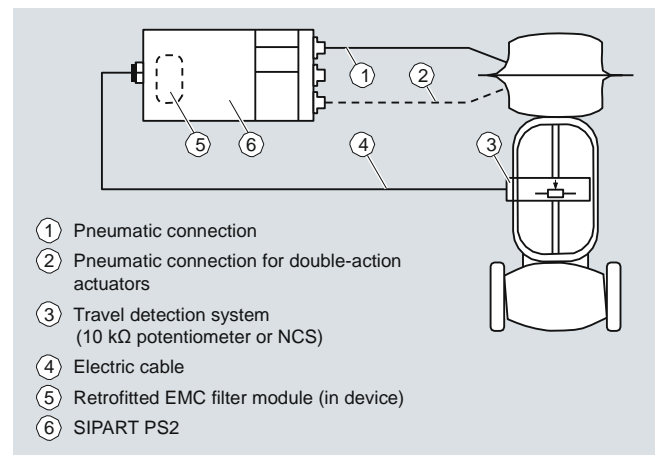

Separate mounting of positioner detection system and controller unit

### Non-contacting position sensor (NCS)

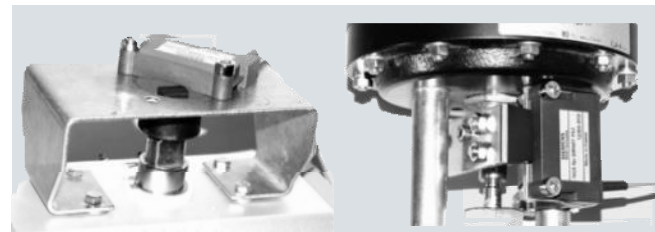

NCS for part-turn actuator (6DR4004-NN10) mounted with mounting console (left) and NCS for linear actuator ≤ 14 mm (0.55 inch) (6DR4004-NN20) mounted with actuator-specific mounting solution (right)



NCS (6DR4004-NN30) for travels > 14 mm (0.55 inch) mounted using mounting kit for NAMUR linear actuator

The NCS sensor consists of a non-contacting position sensor. All coupling elements are omitted such as coupling wheel and driver pin with part-turn actuators or lever and pick-up bracket with linear actuators for up to 14 mm travel.

This results in:

- Even greater resistance to vibration and shock
- No wear of sensor
- Problem-free mounting on very small actuators
- Negligible hysteresis with very small travels.

The sensor does not require an additional power supply, i. e. SIPART PS2 (not for Ex d version) can be operated in a 2-wire system. The NCS (Non Contacting Position Sensor) consists of a potted sensor housing which must be mounted permanently and a magnet which is mounted on the spindle of linear actuators or on the shaft butt of part-turn actuators. For the version for travels >14 mm (0.55 inch), the magnet and the NCS are premounted on a stainless steel frame and offer the same interface mechanically as the positioner itself, i. e. they can be mounted using the standard mounting kits 6DR4004-8V, -8VK and -8VL.

The installation of a EMC filter module in the positioner (controller unit) is necessary in order to ensure a connection level with EMC according to EC Declaration of Conformity when using external sensors (see "Selection and Ordering Data", "EMC Filter Module").

### Function

The SIPART PS2 positioner works in a completely different way to normal positioners.

### Mode of operation

Comparison of the setpoint and the actual value takes place electronically in a microcontroller. If the microcontroller detects a deviation, it uses a 5-way switch procedure to control the piezoelectric valves, which regulates the flow of air into and from the chambers of the pneumatic actuator or blows it in the opposite direction.

The microcontroller then outputs an electric control command to the piezoelectric valve in accordance with the size and direction of the deviation (deviation between setpoint and actual values). The piezoelectric valve converts the command into a pneumatic positional increment.

The positioner outputs a continuous signal in the area where there is a large system deviation (high-speed zone); in areas of moderate system deviation (slow-speed zone) it outputs a sequence of pulses. No positioning signals are output in the case of a small system deviation (adaptive or variable deadband).

The linear or rotary motion of the actuator is detected by the mounting kit and transferred to a high-quality potentiometer over a shaft and a non-floating gear transmission.

The angular error of the pick-up in cases where the assembly is mounted on a linear actuator is corrected automatically.

When connected in a 2-wire system, the SIPART PS2 draws its power exclusively from the 4 to 20 mA setpoint signal. The electric power is also connected through the 2-wire bus signal with PROFIBUS operation (SIPART PS2 PA).

The same applies for the FOUNDATION Fieldbus version.

### Pneumatic valve manifold with piezoelectric valve precontrol

The piezoelectric valve can release very short control pulses. This helps achieve a high positioning accuracy. The pilot element is a piezoelectric bending converter which switches the pneumatic main controller unit. The valve manifold is characterized by an extremely long service life.

### Local operation

Local operation is performed using the built-in display and the three buttons. Switching between the operating levels Automatic, Manual, Configuring and Diagnosis is possible at the press of a button.

In manual mode the drive can be adjusted over the entire range without interrupting the circuit.

### Operation and monitoring with the SIMATIC PDM configuration software

The configuration software SIMATIC PDM permits simple operation, monitoring, configuration and parameterization of the device. The diagnostic information available can be read via SIMATIC PDM from the device. Communication is carried out via the HART protocol or PROFIBUS PA. For the HART protocol, the device can be accessed both via a HART modem and via a HART-compatible input/output module (remote IO). The corresponding device description files, such as GSD and (Enhanced) EDD are available for both types of communication.

In addition, the SITRANS DTM provides software based on tried and tested EDD technology that can be used to parameterize field devices via a DTM (Device Type Manager) using an FDT frame application (e. g. PACTware). SITRANS DTM and the necessary device-specific enhanced EDD are available for download free of charge. The software provides the relevant communication interfaces for HART and PROFIBUS.

### Automatic commissioning

With a simple configuration menu the SIPART PS2 can be quickly adapted to the fitting and adjusted by means of an automatic startup function.

During initialization, the microcontroller determines the zero point, full-scale value, the direction of action and the positioning speed of the fitting. From this data it establishes the minimum pulse time and the deadband, thus optimizing the control.

### Low air consumption

A hallmark of the SIPART PS2 is its own extremely low consumption of air. Normal air losses on conventional positioners are very costly. Thanks to the use of modern piezoelectric technology, the SIPART PS2 consumes air only when it is needed, which means that it pays for itself within a very short time.

### Comprehensive monitoring functions

The SIPART PS2 has various monitoring functions with which changes on the actuator and valve can be detected and signaled if applicable when a selectable limit has been exceeded. This information may be important for diagnosis of the actuator or valve. The measuring data to be determined and monitored, some of whose limits can be adjusted, include:

- Travel integral
- Number of changes in direction
- Alarm counter
- Self-adjusting deadband
- Valve end limit position (e. g. for detection of valve seat wear or deposits)
- Operating hours (also according to temperature and travel ranges) as well as min./max. temperature
- Operating cycles of piezoelectric valves
- Valve positioning time
- Actuator leakages

### Status monitoring with 3-stage alarm concept

The intelligent electropneumatic SIPART PS2 positioner is equipped with additional monitoring functions. The status indications derived from these monitoring functions signal active faults of the unit. The severity of these faults are graded using "traffic light signaling", symbolized by a wrench in the colors green, yellow and red (in SIMATIC PDM and Maintenance Station):

- Need for maintenance (green wrench)
- Urgent need for maintenance (yellow wrench)
- Imminent danger of unit failure or general failure (red wrench)

This allows users to put early measures into action before a serious valve or actuator fault occurs which could result in a system shutdown. The fact that a fault indication is signaled, such as the onset of a diaphragm break in the actuator or the progressive sluggishness of a unit, enables the user to ensure system reliability at any time by means of suitable maintenance strategies.

This three-stage alarm hierarchy also allows early detection and signaling of other faults, such as the static friction of a packing box, the wearing of a valve plug/seating, or precipitations or incrustations on the fittings.

These fault indications can be output either line-conducted over the alarm outputs (see above) of the positioner (max. 3), or via communication over the HART or field bus interfaces. In this case, the HART, PROFIBUS and FF versions of SIPART PS2 permit a differentiation of the various fault indications, as well as a trend representation and histogram function of all key process variables with regard to the fittings.

The device display also displays the graded maintenance requirements, complete with identification of the source of the fault.

### Functional safety acc. to SIL 2

The SIPART PS2 positioners are also suitable for the control of fittings, which meet the special requirements of the functional safety up to SIL 2 to IEC 61508 or IEC 61511-1.

This is a single-action, venting positioner with an input of 4 to 20 mA, PROFIBUS PA and FOUNDATION Fieldbus (FF) for mounting on pneumatic actuators with spring return.

The positioner vents the valve actuator on demand/in the event of a fault and puts the valve in the preset safety position.

This positioner meets the following requirements:

- Functional safety up to SIL 2 conforming to IEC 61508 or IEC 61511-1 for safe venting
- Explosion protection for the versions 6DR5...-E...
- Electromagnetic compatibility to EN 61326/A1, Appendix A.1

### SIPART PS 2 as "intelligent solenoid valve"

Open / Close valves, safety fittings in particular, are generally pneumatically controlled over a solenoid valve. If you use SIPART PS2 instead of this type of solenoid valve, the positioner performs two tasks in a single device (without extra wiring)

- Firstly, it switches the fitting off on demand by venting the actuator (functional safety acc. to SIL 2 (see above))
- Secondly, it can perform a Partial Stroke Test at regular intervals (1 - 365 days), which prevents the blocking of the fitting, e. g. due to corrosion or furring.

As in this case SIPART PS2 is constantly working in normal operation (e. g. 99 % position), it also acts as a permanent test function for the pneumatic output circuit, which is not usually possible when using a solenoid valve.

Solenoid valves on control valves can also not normally be tested during operation. They are therefore not necessary when using SIPART PS 2 with a 4-wire connection system as the venting is carried out on demand by SIPART PS2. This means that on control valves, both the control function and the shut-off function can be carried out by a single device.

### Configuring

In configuring mode, the SIPART PS2 positioner can be configured to requirements and include the following settings:

- Input current range 0 to 20 mA or 4 to 20 mA
- Rising or falling characteristic curve at the setpoint input
- Positioning speed limit (setpoint ramp)
- Split-range operation; adjustable start-of-scale and full-scale values
- Response threshold (deadband); self-adjusting or fixed
- Direction of action; rising or falling output pressure with rising setpoint
- Limits (start-of-scale and full-scale values) of positioning range
- Limits (alarms) of the final control element position; minimum and maximum values
- Automatic "tight shut-off" (with adjustable response threshold)
- The travel can be corrected in accordance with the valve characteristic curve.
- Function of binary inputs
- Function of alarm output etc.

Configuration of the various SIPART PS2 versions is largely identical.

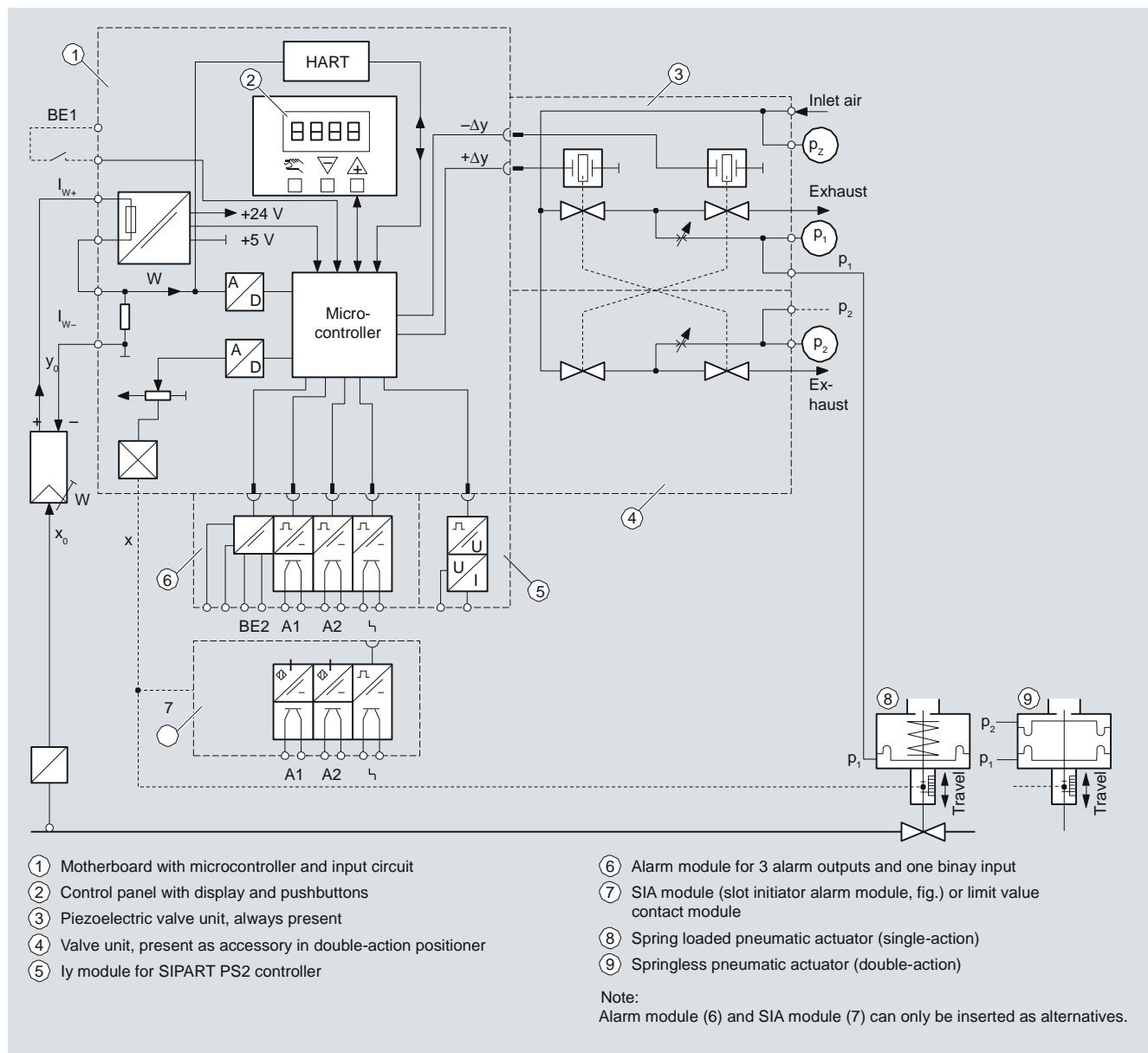

SIPART PS2, electro-pneumatic positioner, function diagram

#### Technical specifications

##### SIPART PS2 (all versions)

Rated conditions	
Permissible ambient temperature for operation	See "Technical Specifications" on page 6/20
Degree of protection <sup>1)</sup>	IP66 according to EN 60529/NEMA 4X
Mounting position	Any; pneumatic connections and exhaust opening not facing up in wet environment
Vibration resistance	
• Harmonic oscillations (sine-wave) according to EN 60068-2-6/05.96	3.5 mm (0.14"), 2 ... 27 Hz, 3 cycles/axis 98.1 m/s <sup>2</sup> (321.84 ft/s <sup>2</sup> ), 27 ... 300 Hz, 3 cycles/axis
• Bumping (half-sine) according to EN 60068-2-29/03.95	150 m/s <sup>2</sup> (492 ft/s <sup>2</sup> ), 6 ms, 1000 shocks/axis
• Noise (digitally controlled) according to EN 60068-2-64/08.95	10 ... 200 Hz; 1 (m/s <sup>2</sup> ) <sup>2</sup> /Hz (3.28 (ft/s <sup>2</sup> ) <sup>2</sup> /Hz) 200 ... 500 Hz; 0.3 (m/s <sup>2</sup> ) <sup>2</sup> /Hz (0.98 (ft/s <sup>2</sup> ) <sup>2</sup> /Hz) 4 hours/axis
• Recommended continuous duty range of the complete fitting	≤ 30 m/s <sup>2</sup> (98.4 ft/s <sup>2</sup> ) without resonance sharpness
Climatic class	According to EN 60721-3-4
• Storage	1K5, but -40 ... +80 °C (1K5, but -40 ... +176 °F)
• Transport	2K4, but -40 ... +80 °C (2K4, but -40 ... +176 °F)
• Operation <sup>2)</sup>	4K3, but -30 ... +80 °C (4K3, but -22 ... +176 °F) <sup>3)</sup>
Pneumatic data	
Auxiliary power (air supply)	Compressed air, carbon dioxide (CO <sub>2</sub> ), nitrogen (N), noble gases or cleaned natural gas
• Pressure	1.4 ... 7 bar (20.3 ... 101.5 psi)
Air quality to ISO 8573-1	
• Solid particulate size and density	Class 2
• Pressure dew point	Class 2 (min. 20 K (36 °F) below ambient temperature)
• Oil content	Class 2
Unrestricted flow (DIN 1945)	
• Inlet air valve (ventilate actuator) <sup>4)</sup>	
- 2 bar (29 psi)	4.1 Nm <sup>3</sup> /h (18.1 USgpm)
- 4 bar (58 psi)	7.1 Nm <sup>3</sup> /h (31.3 USgpm)
- 6 bar (87 psi)	9.8 Nm <sup>3</sup> /h (43.1 USgpm)
• Outlet air valve (vent actuator) <sup>4)</sup>	
- 2 bar (29 psi)	8.2 Nm <sup>3</sup> /h (36.1 USgpm)
- 4 bar (58 psi)	13.7 Nm <sup>3</sup> /h (60.3 USgpm)
- 6 bar (87 psi)	19.2 Nm <sup>3</sup> /h (84.5 USgpm)
Valve leakage	< 6 · 10 <sup>-4</sup> Nm <sup>3</sup> /h (0.0026 USgpm)
Throttle ratio	Adjustable up to ∞ : 1
Auxiliary power consumption in the controlled state	< 3,6 · 10 <sup>-2</sup> Nm <sup>3</sup> /h (0.158 USgpm)

Design	
Mode of operation	
• Range of stroke (linear actuators)	3 ... 130 mm (0.12 ... 5.12") (angle of positioner shaft 16 ... 90°)
• Angle of rotation range (part-turn actuators)	30 ... 100°
Mounting type	
• On linear actuators	Using mounting kit 6DR4004-8V and where necessary with an additional lever arm 6DR4004-8L on actuators according to IEC 60534-6-1 (NAMUR) with ribs, bars or flat face.
• On part-turn actuators	Using mounting kit 6DR4004-8D on actuators with mounting plane according to VDI/VDE 3845 and IEC 60534-6-2: The necessary mounting console is fitted on the actuator side.
Material	
• Enclosure	
- 6DR5..0-... (Makrolon)	Glass-fiber reinforced polycarbonate (PC)
- 6DR5..1-... (aluminum)	GD AISi12
- 6DR5..2-... (stainless steel)	Austenitic stainless steel mat. No. 1.4581
- 6DR5.5-... (aluminum, flame-proof)	GK AISi12
• Pressure gauge block	Aluminium AlMgSi, anodized
Weight, basic device	
• Glass-fiber reinforced enclosure made from polycarbonate	Approx. 0.9 kg (1.98 lb)
• Aluminum enclosure	Approx. 1.3 kg (2.86 lb)
• Stainless steel enclosure	Approx. 3.9 kg (8.6 lb)
• Pressure-proof aluminum enclosure	Approx. 5.2 kg (11.46 lb)
Dimensions	See "Dimensional Drawings" on page 6/33
Device versions	
• In Makrolon enclosure	Single-acting and double-acting
• In aluminum enclosure	Single-action
• In flameproof aluminium enclosure	Single-acting and double-acting
• In stainless steel enclosure	Single-acting and double-acting
Gauge	
• Degree of protection	
- Gauge made of plastic	IP31
- Gauge made of steel	IP44
- Gauge made of stainless steel 316	IP54
• Vibration resistance	According to EN 837-1

<b>Controller</b>	
Controller unit	
• Five-point switch	Self-adjusting
• Deadband	
- dEbA = Auto	Self-adjusting or can be set as fixed value
- dEbA = 0.1 ... 10 %	Self-adjusting or can be set as fixed value
Analog-to-digital converter	
• Scan time	10 ms
• Resolution	≤ 0,05 %
• Transmission error	≤ 0,2 %
• Temperature influence effect	≤ 0.1 %/10 K (≤ 0.1 %/18 °F)
Cycle time	
• 20 mA/HART device	20 ms
• PA device	60 ms
• FF device	60 ms (min. loop time)
<b>Certificates and approvals</b>	
Classification according to pressure equipment directive (PED 97/23/EC)	For gases of fluid group 1, complies with requirements of article 3, paragraph 3 (sound engineering practice SEP)
CE conformity	You can find the appropriate directives and standards, including the relevant versions, in the EC Declaration of Conformity on the Internet.
<b>Explosion protection</b>	
Explosion protection according to ATEX/IECEX	
• Explosion-proof "d"	Zone 1: II 2 G Ex d IIC T6
• Intrinsic safety "ia"	Zone 1: II 2 G Ex ia IIC T6/T4 Gb
• Intrinsic safety "ic"	Zone 2: II 3 G Ex ic IIC T6/T4 Gc
• Energy-limited "nL"	Zone 2: II 3 G Ex nL IIC T6/T4 Gc
• Non-sparking, energy-limited "nA nL"	Zone 2: II 3 G Ex nA nL IIC T6/T4 Gc
• Dust, protection by means of "tD" enclosure	Zone 22: II 3 D Ex tD A22 IP66 T100°C Dc
Explosion protection according to FM/CSA	
• Explosion-proof "d"	
- FM	XP, Class I, Div 1, ABCD XP, Class I; Zone 1, AEx d, IIC, T6/T4
- CSA	Class I, Division 1
• Intrinsic safety "ia"	
- FM	IS, Class I, Div 1, ABCD Class I; Zone 1, AEx ib, IIC, T6/T4
- CSA	Class I, Div 1, ABCD Class I; Zone 1, Ex ib, IIC
• Energy-limited "nL"	
- FM	NI, Class I, Div 2, ABCD NI, Class I; Zone 2, IIC, T6/T4
- CSA	Class I, Div2, ABCD Class I; Zone 2, IIC
Dust, protection by means of "tD" enclosure	
- CSA	Class II, Div 1 Class III, Div 1, Ex d, IIC

<b>Mounting location</b>	
Explosion-proof "d"	Zone 1
Intrinsic safety "ia"	Zone 1
Types of protection "ic", "nL", "nA nL"	Zone 2
Dust, protection by means of "tD" enclosure	ATEX/IECEX; Zone 22 CSA: Class III
<b>Permissible Ambient Temperature</b>	
For operation with and without HART <sup>2)</sup>	Zone 1, 2 and 22 T4: -30 ... +80 °C (-22 ... +176 °F) T6: -30 ... +50 °C (-22 ... +122 °F)
For operation with PROFIBUS PA or with FOUNDATION fieldbus <sup>2)</sup>	Zone 1 T4: -30 ... +80 °C (-22 ... +176 °F) T6: -30 ... +50 °C (-22 ... +122 °F)
	Zone 2 and 22 T4: -20 ... +75 °C (-4 ... +103 °F) T6: -20 ... +50 °C (-4 ... +122 °F)
<b>Natural gas as driving medium</b>	
	For technical specifications using natural gas as driving medium, see operating instructions.

- <sup>1)</sup> Max. impact energy 1 Joule for enclosure with inspection window 6DR5..0 and 6DR5..1.
- <sup>2)</sup> At ≤ -10 °C (≤ 14 °F) the display refresh rate of the indicator is limited. For basic devices with Ex protection the following applies: Only T4 permissible when using with Iy module.
- <sup>3)</sup> -20 ... +80 °C (-4 ... + 176 °F) for 6DR55..-0G..., 6DR56..-0G..., 6DR55..-0D... and 6DR56..-0D...
- <sup>4)</sup> With Ex d version (6DR5..5-...) values reduced by approx. 20 %.

### SIPART PS2 with and without HART

	Basic device without Ex protection	Basic device with Ex d explosion protection	Basic device with "ia" explosion protection	Basic device with explosion protection "ic", "nL", "nA nL", "tD"
<b>Electrical specifications</b>				
Current input $I_W$				
• Rated signal range			0/4 ... 20 mA	
• Load voltage at 20 mA	$\leq 0.2 \text{ V (= } 10 \text{ } \Omega)$	$\leq 0.2 \text{ V (= } 10 \text{ } \Omega)$	$\leq 1 \text{ V (= } 50 \text{ } \Omega)$	$\leq 1 \text{ V (= } 50 \text{ } \Omega)$
• Test voltage			840 V DC, 1 s	
• Binary input BE1 (terminals 9/10; electrically connected to the basic device)		Suitable only for floating contact; max. contact load $< 5 \text{ } \mu\text{A}$ at 3 V		
2-wire connection (terminals 6/8) 6DR50.. and 6DR53.. without HART 6DR51.. and 6DR52.. with HART				
Current to maintain the auxiliary power supply			$\geq 3.6 \text{ mA}$	
Required load voltage $U_B$ (corresponds to $\Omega$ at 20mA)				
• Without HART (6DR50..)				
- Typical	6.36 V (= 318 $\Omega$ )	6.36 V (= 318 $\Omega$ )	7.8 V (= 390 $\Omega$ )	7.8 V (= 390 $\Omega$ )
- max.	6.48 V (= 324 $\Omega$ )	6.48 V (= 324 $\Omega$ )	8.3 V (= 415 $\Omega$ )	8.3 V (= 415 $\Omega$ )
• Without HART (6DR53..)				
- Typical	7.9 V (= 395 $\Omega$ )	-	-	-
- max.	8.4 V (= 420 $\Omega$ )	-	-	-
• With HART (6DR51..)				
- Typical	6.6 V (= 330 $\Omega$ )	6.6 V (= 330 $\Omega$ )	-	-
- max.	6.72 V (= 336 $\Omega$ )	6.72 V (= 336 $\Omega$ )	-	-
• With HART (6DR52..)				
- Typical	-	8.4 V (= 420 $\Omega$ )	8.4 V (= 420 $\Omega$ )	8.4 V (= 420 $\Omega$ )
- max.	-	8.8 V (= 440 $\Omega$ )	8.8 V (= 440 $\Omega$ )	8.8 V (= 440 $\Omega$ )
• Static destruction limit	$\pm 40 \text{ mA}$	$\pm 40 \text{ mA}$	-	-
Effective internal capacitance $C_i$				
• Without HART				
-	-	-	22 nF	"ic"/"nL": 22 nF
• With HART				
-	-	-	7 nF	"ic"/"nL": 7 nF
Effective internal inductance $L_i$				
• Without HART				
-	-	-	0.12 mH	"ic"/"nL": 0.12 mH
• With HART				
-	-	-	0.24 mH	"ic"/"nL": 0.24 mH
For connecting to circuits with the following peak values				
-	-	-	$U_n = 30 \text{ V DC}$ $I_i = 100 \text{ mA}$ $P_i = 1 \text{ W}$	"ic"/"nL": $U_i = 30 \text{ V DC}$ $I_i = 100 \text{ mA}$ "nA nL"/"tD": $U_n \leq 30 \text{ V DC}$ $I_n \leq 100 \text{ mA}$
3-/4-wire connection (terminals 2/4 and 6/8) 6DR52.. with HART, explosion-protected 6DR53.. without HART, not explosion-protected				
Power supply $U_H$	18 ... 35 V DC	18 ... 35 V DC	18 ... 30 V DC	18 ... 30 V DC
• Current consumption $I_H$			$(U_H - 7.5 \text{ V})/2.4 \text{ k}\Omega$ [mA]	
Effective internal capacitance $C_i$				
-	-	-	22 nF	"ic"/"nL": 22 nF
Effective internal inductance $L_i$				
-	-	-	0.12 mH	"ic"/"nL": 0.12 mH
For connecting to circuits with the following peak values				
-	-	-	$U_n = 30 \text{ V DC}$ $I_i = 100 \text{ mA}$ $P_i = 1 \text{ W}$	"ic"/"nL": $U_i = 30 \text{ V DC}$ $I_i = 100 \text{ mA}$ "nA nL"/"tD": $U_n \leq 30 \text{ V DC}$ $I_n \leq 100 \text{ mA}$
Electrical isolation				
	between $U_H$ and $I_W$	between $U_H$ and $I_W$	between $U_H$ and $I_W$ (2 intrinsically safe circuits)	between $U_H$ and $I_W$



	Basic device without Ex protection	Basic device with Ex d explosion protection	Basic device with "ia" explosion protection	Basic device with explosion protection "ic", "nL", "nA nL", "tD"
<b>Design</b>				
Connections, electrical				
• Screw terminals			2.5 AWG28-12	
• Cable gland	M20x1.5 or ½- 14 NPT	Ex d certified cable gland M20x1.5, ½- 14 NPT or M25x1.5	M20x1.5 or ½- 14 NPT	M20x1.5 or ½- 14 NPT
Connections, pneumatic			Female thread G¼ or ¼- 18 NPT	

	Basic device without Ex protection	Basic device with Ex d explosion protection	Basic device with "ia" explosion protection	Basic device with explosion protection "ic", "nL", "nA nL", "tD"
<b>Electrical specifications</b>				
Power supply, bus circuit (terminals 6/7)	Bus-supplied			
Bus voltage	9 ... 32 V	9 ... 32 V	9 ... 24 V	9 ... 32 V
For connecting to circuits with the following peak values				
• Bus connection with FISCO supply unit			$U_i = 17.5 \text{ V DC}$ $I_i = 380 \text{ mA}$ $P_i = 5.32 \text{ W}$	"ic"/"nL": $U_i = \text{DC } 17.5 \text{ V}$ $I_i = 570 \text{ mA}$ "nA nL"/"tD": $U_n \leq 32 \text{ V DC}$
• Bus connection with barrier			$U_i = 24 \text{ V DC}$ $I_i = 250 \text{ mA}$ $P_i = 1.2 \text{ W}$	"ic"/"nL": $U_i = 32 \text{ V DC}$ "nA nL"/"tD": $U_n \leq 32 \text{ V DC}$
Effective internal capacitance $C_i$	-	-	Negligible	Negligible
Effective internal inductance $L_i$	-	-	8 $\mu\text{H}$	8 $\mu\text{H}$
Current consumption	11.5 mA $\pm$ 10 %			
Additional error signal	0 mA			
Safety shutdown can be activated with coding bridge (terminals 81/82)	electrically isolated from bus circuit and binary input			
• Input resistance	> 20 k $\Omega$			
• Signal state "0" (shutdown active)	0 ... 4.5 V or unconnected			
• Signal state "1" (shutdown not active)	13 ... 30 V			
For connecting to power supply with the following peak values			$U_i = 30 \text{ V DC}$ $I_i = 100 \text{ mA}$ $P_i = 1 \text{ W}$	"nA nL": $U_n \leq 30 \text{ V DC}$ $I_n \leq 100 \text{ mA}$ "ic"/"nL": $U_i = 30 \text{ V DC}$ $I_i = 100 \text{ mA}$
• Effective Internal capacitance $C_i$	-	-	Negligibly small	Negligibly small
Binary input BE1 for PROFIBUS (terminals 9/10); electrically connected to the bus circuit)	Bridged or connection to switching contact. Suitable only for floating contact; max. contact load < 5 $\mu\text{A}$ at 3 V			
Electrical isolation	Electrical isolation between basic device and the input for safety shutdown, as well as the outputs of the option modules			
• For basic device without Ex protection and for basic device with Ex d	The basic device and the input to the safety shutdown, as well as the outputs of the option modules, are separate, intrinsically safe circuits.			
• For basic device Ex "ia"	Electrical isolation between basic device and the input for safety shutdown, as well as the outputs of the option modules			
• For basic device Ex "ic", "nL", "nA nL", "tD"	Electrical isolation between basic device and the input for safety shutdown, as well as the outputs of the option modules			
Test voltage	840 V DC, 1 s			
<b>Design</b>				
Connections, electrical	2.5 AWG28-12			
• Screw terminals	M20x1.5 or 1/2-14 NPT			
• Cable gland	M20x1.5 or 1/2-14 NPT	Ex d certified cable gland M20x1.5; 1/2-14 NPT or M25x1.5	M20x1.5 or 1/2-14 NPT	M20x1.5 or 1/2-14 NPT
Connections, pneumatic	Female thread G1/4 or 1/4" -18 NPT			
<b>PROFIBUS PA communication</b>				
Communication	Layers 1 and +2 according to PROFIBUS PA, transmission technology according to IEC 61158-2; slave function; layer 7 (protocol layer) according to PROFIBUS DP, EN 50170 standard with the extended PROFIBUS functions (all data acyclic, manipulated variable, feedbacks and status also cyclic)			
C2 connections	Four connections to master class 2 are supported; automatic connection setup 60 s after break in communication			
Device profile	PROFIBUS PA profile B, version 3.0, more than 150 objects			
Response time to master message	Typically 10 ms			
Device address	126 (when delivered)			
PC parameterizing software	SIMATIC PDM; supports all device objects. The software is not included in the scope of delivery.			

	Basic device without Ex protection	Basic device with Ex d explosion protection	Basic device with "ia"explosion protection	Basic device with explosion protection "ic", "nL", "nA nL", "tD"
<b>FOUNDATION fieldbus communication</b>				
Communications group and class	According to technical specification of the Fieldbus Foundation for H1 communication			
Function blocks	Group 3, Class 31PS (Publisher Subscriber) 1 Resource Block (RB2) 1 Analog Output Function Block (AO) 1 PID Function Block (PID) 1 Transducer Block (Standard Advanced Positioner Valve)			
Execution times of the blocks	AO: 60 ms PID: 80 ms			
Physical layer profile	123, 511			
FF registration	Tested with ITK 5.0			
Device address	22 (when delivered)			

	Without Ex protection/ with Ex protection Ex d	With explosion protection "ia"	With explosion protection "ic", "nL", "nA nL", "tD"
<b>Alarm unit</b>	<b>6DR4004-8A</b>	<b>6DR4004-6A</b>	<b>6DR4004-6A</b>
3 binary output circuits		<ul style="list-style-type: none"> <li>Alarm output A1: Terminals 31 and 32</li> <li>Alarm output A2: Terminals 41 and 42</li> <li>Alarm output: Terminals 51 and 52</li> </ul>	
• Power supply $U_H$	$\leq 35$ V	-	-
• Signal state			
- High (not activated)	Conductive, $R = 1$ k $\Omega$ , $+3/-1$ % *)	$\geq 2.1$ mA	$\geq 2.1$ mA
- Low *) (activated)	Blocked, $I_R < 60$ $\mu$ A	$\leq 1.2$ mA	$\leq 1.2$ mA
*) Low is also the status when the basic device is faulty or is without additional electrical power supply.	*) When used in the flameproof enclosure the current consumption must be limited to 10 mA per output.	Switching threshold with supply to EN 60947-5-6: $U_H = 8.2$ V, $R_i = 1$ k $\Omega$	Switching threshold with supply to EN 60947-5-6: $U_H = 8.2$ V, $R_i = 1$ k $\Omega$
• For connecting to circuits with the following peak values		$U_i = 15.5$ V DC $I_i = 25$ mA $P_i = 64$ mW	"ic"/"nL": $U_i = 25.2$ V DC "nA nL": $U_n \leq 15.5$ V DC
• Effective Internal capacitance $C_i$	-	5.2 nF	5.2 nF (at "nL")
• Effective internal inductance $L_i$	-	Negligibly small	Negligibly small
1 binary output circuit		Binary input BE2: Terminals 11 and 12, terminals 21 and 22 (bridge)	
• Electrically connected to the basic device			
- Signal state 0		Floating contact, open	
- Signal state 1		Floating contact, closed	
- Contact load		3 V, 5 $\mu$ A	
• Electrically isolated from the basic device			
- Signal state 0		$\leq 4.5$ V or open	
- Signal state 1		$\geq 13$ V	
- Natural resistance		$\geq 25$ k $\Omega$	
• Static destruction limit	$\pm 35$ V	-	-
• Connecting to circuits with the following peak values	-	$U_i = 25.2$ V DC	"ic"/"nL": $U_i = 25.2$ V DC "nA nL": $U_n \leq 25.5$ V DC
• Effective internal inductance and capacitance	-	Negligibly small	Negligibly small
Electrical isolation	The 3 outputs, the input BE2 and the basic device are electrically isolated from each other		
Test voltage	840 V DC, 1 s		
<b>I<sub>y</sub> module</b>	<b>6DR4004-8J</b>	<b>6DR4004-6J</b>	<b>6DR4004-6J</b>
DC output for position feedback		2-wire connection	
1 current output: Terminals 61 and 62		4 ... 20 mA, short-circuit proof	
Rated signal range		3.6 ... 20.5 mA	
Total operating range			
Power supply $U_H$	+12 ... +35 V	+12 ... +30 V	+12 ... +30 V
External loads $R_B$ [k $\Omega$ ]	$\leq (U_H [V] - 12 V) / i$ [mA]		
Transmission error		$\leq 0,3$ %	
Temperature influence effect		$\leq 0.1$ %/10 K ( $\leq 0.1$ %/18 °F)	
Resolution		$\leq 0,1$ %	
Residual ripple		$\leq 1$ %	
For connecting to circuits with the following peak values		$U_i = 30$ V DC $I_i = 100$ mA $P_i = 1$ W	"ic"/"nL": $U_i = 30$ V DC $I_i = 100$ mA "nA nL"/"tD": $U_n \leq 30$ V DC $I_n \leq 100$ mA $P_n \leq 1$ W
Effective internal capacitance $C_i$	-	11 nF	11 nF
Effective internal inductance $L_i$	-	Negligibly small	Negligibly small
Electrical isolation	Electrically isolated from the alarm option and safely isolated from the basic device		
Test voltage	840 V DC, 1 s		

	Without Ex protection	With explosion protection "ia"	With explosion protection "ic", "nL", "nA nL", "tD"
<b>SIA module</b>	<b>6DR4004-8G</b>	<b>6DR4004-6G</b>	<b>6DR4004-6G</b>
Limit transmitter with slot-type initiators and alarm output			
2 slot-type initiators		<ul style="list-style-type: none"> <li>Binary output (limit transmitter) A1: Terminals 41 and 42</li> <li>Binary output (limit transmitter) A2: Terminals 51 and 52</li> </ul>	
<ul style="list-style-type: none"> <li>Connection</li> <li>Signal state Low (activated)</li> <li>2 slot-type initiators</li> <li>Function</li> <li>Connecting to circuits with the following peak values</li> </ul>	Rated voltage 8 V current consumption: $\geq 3$ mA (limit value not responded), $\leq 1$ mA (limit value responded)	2-wire system to EN 60947-5-6 (NAMUR), for switching amplifier to be connected on load side $< 1.2$ mA Type SJ2-SN NC (normally closed)	
<ul style="list-style-type: none"> <li>Effective Internal capacitance <math>C_i</math></li> <li>Effective internal inductance <math>L_i</math></li> </ul>	-	$U_i = 15.5$ V DC $I_i = 25$ mA $P_i = 64$ mW 41 nF 100 $\mu$ H	"ic"/"nL": $U_i = 15.5$ V DC $I_i = 25$ mA "nA nL"/"tD": $U_n \leq$ DC 15.5 V $P_n \leq 64$ mW 41 nF 100 $\mu$ H
1 alarm output		Binary output: Terminals 31 and 32	
<ul style="list-style-type: none"> <li>Connection</li> <li>Signal state High (not activated)</li> <li>Signal state Low (activated)</li> <li>Power supply <math>U_H</math></li> <li>Connecting to circuits with the following peak values</li> </ul>	$R = 1.1$ k $\Omega$ $R = 10$ k $\Omega$ $U_H \leq 35$ V DC $I \leq 20$ mA	On switching amplifier according to EN 60947-5-6: (NAMUR), $U_H = 8.2$ V, $R_i = 1$ k $\Omega$ . $> 2.1$ mA $< 1.2$ mA - $U_i = 15.5$ V DC $I_i = 25$ mA $P_i = 64$ mW	$> 2.1$ mA $< 1.2$ mA - "ic"/"nL": $U_i = 15.5$ V DC $I_i = 25$ mA "nA nL": $U_n \leq$ DC 15.5 V $P_n \leq 64$ mW
<ul style="list-style-type: none"> <li>Effective Internal capacitance <math>C_i</math></li> <li>Effective internal inductance <math>L_i</math></li> </ul>	-	$\leq 5.2$ nF Negligibly small	$\leq 5.2$ nF Negligibly small
Electrical isolation		The 3 outputs are electrically isolated from the basic device.	
Test voltage		840 V DC, 1 s	
<b>Limit value contact module</b>	<b>6DR4004-8K</b>	<b>6DR4004-6K</b>	<b>6DR4004-6K</b>
Limit transmitter with mechanical switching contacts			
2 limit value contacts		<ul style="list-style-type: none"> <li>Binary output A1: Terminals 41 and 42</li> <li>Binary output A2: Terminals 51 and 52</li> </ul>	
<ul style="list-style-type: none"> <li>Max. switching current AC/DC</li> <li>For connecting to circuits with the following peak values</li> </ul>	-	4 A $U_i = 30$ V DC $I_i = 100$ mA $P_i = 750$ mW	"ic"/"nL": $U_i = 30$ V DC $I_i = 100$ mA "nA nL": $U_n \leq 15.5$ V DC
<ul style="list-style-type: none"> <li>Effective internal capacitance and inductance</li> </ul>	-	Negligibly small	Negligibly small
<ul style="list-style-type: none"> <li>Max. switching voltage AC/DC</li> </ul>	250 V/24 V	30 V DC	30 V DC
1 alarm output		Binary output: Terminals 31 and 32	
<ul style="list-style-type: none"> <li>Connection</li> <li>Signal state High (not activated)</li> <li>Signal state Low (activated)</li> <li>Auxiliary power</li> <li>Connecting to circuits with the following peak values</li> </ul>	$R = 1.1$ k $\Omega$ $R = 10$ k $\Omega$ $U_H \leq 35$ V DC $I \leq 20$ mA	On switching amplifier according to EN 60947-5-6: (NAMUR), $U_H = 8.2$ V, $R_i = 1$ k $\Omega$ . $> 2.1$ mA $< 1.2$ mA - $U_i = 15.5$ V DC $I_i = 25$ mA $P_i = 64$ mW	- $> 2.1$ mA $< 1.2$ mA - "ic"/"nL": $U_i = 15.5$ V $I_i = 25$ mA

# Positioners

## SIPART PS2

### Selection and Ordering data SIPART PS2



	Without Ex protection	With explosion protection "ia"	With explosion protection "ic", "nL", "nA nL", "tD"
• Maximum internal capacitance $C_i$	-	$\leq 5.2$ nF	$\leq 5.2$ nF
• Maximum internal inductance $L_i$	-	Negligibly small	Negligibly small
Electrical isolation	The 3 outputs are electrically isolated from the basic device		
Test voltage	3 150 V DC, 2 s		
Rated conditions altitude	Max. 2 000 m NN At altitudes over 2 000 m NN, use a suitable power supply	-	-
<b>EMC filter module</b>	EMC filter module is required for NCS sensor or external potentiometer. External position sensor (potentiometer or NCS; as option) with the following peak values: Printed circuit board for type C73451-A430-L8 external potentiometer		
Resistance of external potentiometer	10 k $\Omega$		
Peak values when supplied via the PROFIBUS basic device			
• Maximum output voltage	-	$U_o = 5$ V	$U_o = 5$ V
• Maximum output current static	-	$I_o = 75$ mA	$I_o = 75$ mA
• Maximum output current static short-term	-	$I_o = 160$ mA	-
• Maximum output power	-	$P_o = 120$ mW	$P_o = 120$ mW
Peak values when supplied via the other basic devices			
• Maximum output voltage	-	$U_o = 5$ V	$U_o = 5$ V
• Maximum output current	-	$I_o = 100$ mA	$I_o = 75$ mA
• Maximum output power	-	$P_o = 33$ mW	$P_o = 120$ mW
Maximum permitted external capacitance	-	$C_o = 1$ $\mu$ F	$C_o = 1$ $\mu$ F
Maximum permitted external inductance	-	$L_o = 1$ mH	$L_o = 1$ mH
Test voltage	840 V DC, 1 s		
<b>NCS sensor</b>			
Position range			
• Linear actuator	3 ... 130 mm (0.12 ... 5.12"); up to 200 mm (7.87") on request		
• Part-turn actuator	30° ... 100°		
Linearity (after correction by positioner)			
• Linear actuator	$\pm 1$ %		
• Part-turn actuator	$\pm 1$ %		
Hysteresis	$\pm 0,2$ %		
Continuous working temperature	-40 °C ... +85 °C (-40 °F ... +185 °F), extended temperature range on request		
Vibration resistance			
• Harmonic oscillations (sine-wave) according to EN 60068-2-6/05.96	7 mm (0.28"), 5 ... 54 Hz; 500 m/s <sup>2</sup> (1640 ft/s <sup>2</sup> ), 80 ... 200 Hz		
Degree of protection of enclosure	IP68/NEMA 4X		
For connecting to circuits with the following peak values	-	Intrinsically safe $U_i = 5$ V DC	at "nL": $U_i = 5$ V DC
Maximum internal capacitance $C_i$	-	10 nF	10 nF (at "nL")
Maximum internal inductance $L_i$	-	240 $\mu$ H	240 $\mu$ H (at "nL")

Selection and ordering data	Order No.	Order code	Selection and ordering data	Order No.	Order code
<b>SIPART PS2 electropneumatic positioner, without Ex protection, with "Ex i" and with "Ex n"</b>	6 DR 5	777 - 0 77777 - 77A7 777	<b>SIPART PS2 electropneumatic positioner, without Ex protection, with "Ex i" and with "Ex n"</b>	6 DR 5	777 - 0 77777 - 77A7 777
<b>Version</b>			<b>Limit monitor</b>		
2-wire (4 to 20 mA)			Installed, incl. 2nd cable gland		
• <u>Without</u> HART } 0			Without } 0		
• <u>With</u> HART, <u>not</u> explosion-protected } 1			Alarm module; electronic (6DR4004-.A)	1	
2-, 3-, 4-wire (0/4 to 20 mA)			SIA module; slot-type initiators (6DR4004-.G)	2	
• <u>With</u> HART, explosion-protected } 2			Limit value contact module (mechanical switching contacts (6DR4004-.K)	3	
• <u>Without</u> HART, <u>not</u> explosion-protected } 3					
PROFIBUS PA connection } 5			<b>Option modules</b>		
FOUNDATION Fieldbus connection } 6			Installed, incl. 2nd cable gland		
			Without } 0		
<b>For actuator</b>			ly module for position feedback signal (4 ... 20 mA) (6DR4004-.J)	1	
Single-action } 1			EMC filter module for external position sensor in the SIPART PS2 enclosure (C73451-A430-D23), NCS sensor 6DR4004-.NN.0 and external position sensing with non-Siemens potentiometer	2	
Double-action } 2			ly module and EMC filter module for external position sensor	3	
<b>Enclosure</b>			<b>Customer-specific design</b>		
Makrolon } 0			Without } 0		
Aluminum; only single-action } 1 1			<b>Brief instructions</b>		
Stainless steel (without window) } 2			German/English } A		
			French/Spanish/Italian } B		
<b>Explosion protection</b>			<b>Mounted pressure gauge block</b>		
Without } N			Without } 0		
In type of protection (ATEX/IECEX/FM/CSA)		E	<u>Gauge made of plastic</u>		
• intrinsic safety "Ex ia", Zone 1			Block made of aluminum, single-acting G $\frac{1}{4}$ , scaled in MPa, bar, psi	1	
In type of protection (ATEX/IECEX) <sup>1)</sup>		D	Block made of aluminum, double-acting G $\frac{1}{4}$ , scaled in MPa, bar, psi	2	
• non-sparking "Ex nA", zone 2			Block made of aluminum, single-acting $\frac{1}{4}$ -18 NPT, scaled in MPa, bar, psi	3	
• energy-limited "Ex nL", zone 2			Block made of aluminum, single-acting $\frac{1}{4}$ -18 NPT, scaled in MPa, bar, psi	4	
• dust protection via enclosure "Ex tD", zone 22			<u>Gauge made of steel</u>		
In type of protection (ATEX/IECEX/FM) <sup>2)</sup>		F	block made of aluminium, single-action G $\frac{1}{4}$ , scaled in MPa, bar, psi	9	R 1 A
• intrinsic safety "Ex ia", zone 1			Block made of aluminium, double-action G $\frac{1}{4}$ , scaled in MPa, bar, psi	9	R 2 A
• intrinsic safety "Ex ic", zone 2			Block made of aluminium, single-action $\frac{1}{4}$ -18 NPT, scaled in MPa, bar, psi	9	R 1 B
• non-sparking "Ex nA", zone 2			Block made of aluminium, double-action $\frac{1}{4}$ -18 NPT, scaled in MPa, bar, psi	9	R 2 B
• energy-limited "Ex nL", zone 2			<u>Gauge made of stainless steel 316</u>		
In type of protection (ATEX/IECEX/FM) <sup>2)</sup>		G	Block made of stainless steel 316, single-action G $\frac{1}{4}$ , scaled in MPa, bar, psi	9	R 1 C
• non-sparking "Ex nA", zone 2			Block made of stainless steel 316, double-action G $\frac{1}{4}$ , scaled in MPa, bar, psi	9	R 2 C
• energy-limited "Ex nL", zone 2			Block made of stainless steel 316, single-action $\frac{1}{4}$ -18 NPT, scaled in MPa, bar, psi	9	R 1 D
In type of protection (ATEX/IECEX) <sup>1)</sup>		K	Block made of stainless steel 316, double-action $\frac{1}{4}$ -18 NPT, scaled in MPa, bar, psi	9	R 2 D
• intrinsic safety "Ex ia", zone 1					
• intrinsic safety "Ex ic", zone 2					
• non-sparking "Ex nA", zone 2					
• energy-limited "Ex nL", zone 2					
• dust protection via enclosure "Ex tD", zone 22					
<b>Connection thread electrical/pneumatic</b>					
With cable gland M20x1.5/G $\frac{1}{4}$ } G					
With cable gland $\frac{1}{2}$ -14 NPT / $\frac{1}{4}$ -18 NPT } N					
With cable gland M20x1.5/ $\frac{1}{4}$ -18 NPT } M					
With cable gland $\frac{1}{2}$ -14 NPT / G $\frac{1}{4}$ } P					
With plug M12 / G $\frac{1}{4}$ } R					
With plug M12 / $\frac{1}{4}$ -18 NPT } S					

# Positioners

## SIPART PS2

### Selection and Ordering data SIPART PS2

Selection and ordering data	Order No.	Order code
<b>SIPART PS2 electropneumatic positioner, without Ex protection, with "Ex i" and with "Ex n"</b>	6 DR 5	777 - 0 7777 - 77 A 7 777
<b>Further designs</b> Add "-Z" to order no. and specify order code.		Order code
<b>Pneumatic terminal block made of stainless steel 316</b> For device versions in Makrolon enclosure	<b>K18</b>	
<b>Version with stainless steel sound absorbers</b> Standard with stainless steel enclosure	<b>A40</b>	
<b>Measuring point number (TAG No.)</b> Max. 8 characters for HART, max. 32 characters for PROFIBUS PA, FOUNDATION Fieldbus and 4 ... 20 mA, specify in plain text: <b>Y17: .....</b>	<b>Y17<sup>3)</sup></b>	
<b>Measuring point description</b> Max. 16 characters for HART, max. 32 characters for PROFIBUS PA, FOUNDATION Fieldbus and 4 ... 20 mA, specify in plain text: <b>Y15: .....</b>	<b>Y15<sup>3)</sup></b>	
<b>Measuring point text</b> Max. 24 characters for HART, max. 32 characters for PROFIBUS PA, FOUNDATION Fieldbus and 4 ... 20 mA, specify in plain text: <b>Y16: .....</b>	<b>Y16<sup>3)</sup></b>	
<b>TAG plate made of stainless steel, 3-line</b> Text line 1: Plain text from Y17 Text line 2: Plain text from Y15 Text line 3: Plain text from Y16	<b>Y20<sup>3)</sup></b>	
<b>Preset bus address</b> Specify in plain text: <b>Y25: .....</b> (only for 6DR55.. and 6DR56..)	<b>Y25<sup>3)</sup></b>	

} Available ex stock (select combinations)

- 1) Enclosure: aluminum or stainless steel, each without inspection window in the cover
- 2) Enclosure: aluminum or Makrolon, each with inspection window in the cover Max. impact energy 1 Joule for enclosure with inspection window 6DR5..0 und 6DR5..1.
- 3) Only for Makrolon enclosure, for other enclosures on request.



Selection and ordering data	Order No.	Order code	Selection and ordering data	Order No.	Order code
<b>SIPART PS2 electropneumatic positioner, Ex d explosion protection, aluminum enclosure, without cable gland</b>	6 DR 5	775 - 0E777 - 77A7 777	<b>SIPART PS2 electropneumatic positioner, Ex d explosion protection, aluminum enclosure, without cable gland</b>	6 DR 5	775 - 0E777 - 77A7 777
<b>Version</b>			<b>Mounted pressure gauge block</b>		
2-wire (4 to 20 mA)			Without		0
• <u>Without</u> HART	} 0		Gauge made of plastic, block made of aluminium, single-action G $\frac{1}{4}$ , scaled in MPa and bar		1
• <u>With</u> HART	} 1		Gauge made of plastic, block made of aluminium, double-action G $\frac{1}{4}$ , scaled in MPa and bar		2
2-, 3-, 4-wire (0/4 to 20 mA)			Gauge made of plastic, block made of aluminium, single-action $\frac{1}{4}$ -18 NPT, scaled in MPa and psi		3
• <u>With</u> HART	} 2		Gauge made of plastic, block made of aluminium, double-action $\frac{1}{4}$ -18 NPT, scaled in MPa and psi		4
• <u>Without</u> HART	} 3		<u>Gauge made of steel</u>		9 R 1 A
PROFIBUS PA connection	} 5		block made of aluminium, single-action G $\frac{1}{4}$ , scaled in MPa, bar, psi		9 R 2 A
FOUNDATION Fieldbus connection	} 6		Block made of aluminium, double-action G $\frac{1}{4}$ , scaled in MPa, bar, psi		9 R 1 B
<b>For actuator</b>			Block made of aluminium, single-action $\frac{1}{4}$ -18 NPT, scaled in MPa, bar, psi		9 R 2 B
Single-action	} 1		<u>Gauge made of stainless steel 316</u>		9 R 1 C
Double-action	} 2		Block made of stainless steel 316, single-action G $\frac{1}{4}$ , scaled in MPa, bar, psi		9 R 2 C
<b>Connection thread electrical/pneumatic</b>			Block made of stainless steel 316, double-action G $\frac{1}{4}$ , scaled in MPa, bar, psi		9 R 1 D
M20 x 1.5 / G $\frac{1}{4}$		G	Block made of stainless steel 316, single-action $\frac{1}{4}$ -18 NPT, scaled in MPa, bar, psi		9 R 2 D
$\frac{1}{2}$ -14 NPT / $\frac{1}{4}$ -18 NPT		N	<b>Further designs</b>	Order code	
M20 x 1.5 / $\frac{1}{4}$ -18 NPT		M	Add "-Z" to order no. and specify order code.		
$\frac{1}{2}$ -14 NPT / G $\frac{1}{4}$		P	<b>Measuring point number (TAG No.)</b>	Y17 <sup>1)</sup>	
M25x1.5 / G $\frac{1}{4}$		Q	Max. 8 characters for HART, max. 32 characters for PROFIBUS PA and FOUNDATION Fieldbus, specify in plain text: Y17: .....	Y15 <sup>1)</sup>	
<b>Limit monitor</b>			<b>Measuring point description</b>	Y16 <sup>1)</sup>	
Built-in		0	Max. 16 characters for HART, max. 32 characters for PROFIBUS PA and FOUNDATION Fieldbus, specify in plain text: Y15: .....	A20 <sup>1)</sup>	
Without	} 0		<b>Measuring point text</b>	Y25 <sup>1)</sup>	
Alarm module; electronic (6DR4004-8A)	} 1		Max. 24 characters for HART, max. 32 characters for PROFIBUS PA and FOUNDATION Fieldbus, specify in plain text: Y16: .....		
<b>Option modules</b>			<b>TAG plate made of stainless steel, 3-line</b>		
Built-in		0	Text line 1: Plain text from Y17		
Without	} 0		Text line 2: Plain text from Y15		
ly module for position feedback signal (4 ... 20 mA) (6DR4004-8J)	} 1		Text line 3: Plain text from Y16		
<b>Customer-specific design</b>			<b>Preset bus address</b>		
Without	} 0		Specify in plain text: Y25: .....		
<b>Brief instructions</b>			only for 6DR55.. and 6DR56..)		
German/English	} A		} Available ex stock (select combinations)		
French/Spanish/Italian	} B				

<sup>1)</sup> On request.

# Positioners

## SIPART PS2

### Selection and Ordering data Accessories



Selection and ordering data	Order No.	Selection and ordering data	Order No.
<b>Accessories</b> <b>ly module</b> for position feedback signal (4 ... 20 mA) <ul style="list-style-type: none"> <li>Without explosion protection } <b>6DR4004-8J</b></li> <li>With explosion protection CENELEC/ATEX } <b>6DR4004-6J</b></li> <li>With explosion protection FM/CSA } <b>6DR4004-7J</b></li> </ul> <b>Alarm unit</b> for 3 alarm outputs and 1 binary input (functionality: 2 limit monitors, 1 fault alarm, 1 binary input) <ul style="list-style-type: none"> <li>Without explosion protection } <b>6DR4004-8A</b></li> <li>With explosion protection CENELEC/ATEX } <b>6DR4004-6A</b></li> <li>With explosion protection FM/CSA } <b>6DR4004-7A</b></li> </ul> <b>SIA module</b> (slot-type initiator alarm unit, not for Ex d version) <ul style="list-style-type: none"> <li>Without explosion protection } <b>6DR4004-8G</b></li> <li>With CENELEC/ATEX and FM/CSA explosion protection } <b>6DR4004-6G</b></li> </ul> <b>Limit value contact module</b> (with mechanical ground contacts, not for Ex d version) <ul style="list-style-type: none"> <li>Without explosion protection } <b>6DR4004-8K</b></li> <li>With explosion protection } <b>6DR4004-6K</b></li> </ul> <b>EMC filter module</b> for connection of external position sensor (10 kΩ) or NCS sensor (not for Ex d version) } <b>C73451-A430-D23</b>		<b>External position detection system</b> (with explosion protection to CENELEC/ATEX, Ex i) for separate mounting of position sensor and controller unit (not for Ex d version), comprising SIPART PS2 Makrolon enclosure with integral potentiometer and sliding clutch (without electronics and valve block) The EMC filter module is additionally required for the controller unit. (separate ordering item, see above).	<b>C73451-A430-D78</b>
<b>Selection and ordering data</b>	<b>Order No.</b>	<b>Gauge block with</b> 2 gauges made of plastic, block made of aluminium, single-action G¼, scaled in MPa and bar } <b>6DR4004-1M</b> 3 gauges made of plastic, block made of aluminium, double-action G¼, scaled in MPa and bar } <b>6DR4004-2M</b> 2 gauges made of plastic, block made of aluminium, single-action G¼-18 NPT, scaled in MPa and psi } <b>6DR4004-1MN</b> 3 gauges made of plastic, block made of aluminium, double-action G¼-18 NPT, scaled in MPa and psi } <b>6DR4004-2MN</b> 2 gauges made of steel } <b>6DR4004-1P</b> Block made of aluminum, single-action G¼, scaled in MPa, bar, psi } <b>6DR4004-2P</b> 3 gauges made of steel } <b>6DR4004-2P</b> Block made of aluminum, double-action G¼, scaled in MPa, bar, psi } <b>6DR4004-1PN</b> 2 gauges made of steel } <b>6DR4004-1PN</b> Block made of aluminum, single-action ¼-18 NPT, scaled in MPa, bar, psi } <b>6DR4004-2PN</b> 3 gauges made of steel } <b>6DR4004-2PN</b> Block made of aluminum, double-action ¼-18 NPT, scaled in MPa, bar, psi } <b>6DR4004-1Q</b> 2 gauges made of stainless steel 316 } <b>6DR4004-1Q</b> Block made of stainless steel 316, single-action G¼, scaled in MPa, bar, psi } <b>6DR4004-2Q</b> 3 gauges made of stainless steel 316 } <b>6DR4004-2Q</b> Block made of stainless steel 316, double-action G¼, scaled in MPa, bar, psi } <b>6DR4004-1QN</b> 2 gauges made of stainless steel 316 } <b>6DR4004-1QN</b> Block made of stainless steel 316, single-action ¼-18 NPT, scaled in MPa, bar, psi } <b>6DR4004-2QN</b> 3 gauges made of stainless steel 316 } <b>6DR4004-2QN</b> Block made of stainless steel 316, double-action ¼-18 NPT, scaled in MP, bar, psi } <b>6DR4004-2QN</b>	
<b>Accessories</b> <b>NCS sensor</b> for non-contacting detection of position (not for Ex d version), cable length 6 m (19.68 ft) Non explosion-proof } <b>8</b> Explosion protection, Ex i } <b>6</b> For part-turn actuators, mounting using mounting console (separate ordering item, see accessories) } <b>1</b> For linear actuators up to 14 mm (0.55 inch), mounting using actuator-specific mounting solution } <b>2</b> For linear actuators > 14 mm (0.55 inch), to 130 mm (5.12 inch), mounting using mounting kit for NAMUR linear actuators (separate ordering item, see accessories) } <b>3</b> The EMC filter module is additionally required for the controller unit (separate ordering item, see below)	<b>6DR4004-7NN70</b>	<b>Pneumatic terminal block made of stainless steel 316</b> to replace the pneumatic terminal block made of aluminium for SIPART PS2 with Makrolon enclosure Single-action with G¼ } <b>6DR4004-1R</b> Double-action with G¼ } <b>6DR4004-2R</b> Single-action with ¼-18 NPT } <b>6DR4004-1RN</b> Double-action with ¼-18 NPT } <b>6DR4004-2RN</b>	
		<b>Mounting kit for NAMUR part-turn actuators</b> (VDI/VE 3845, with plastic coupling wheel, without mounting console) } C) <b>6DR4004-8D</b> (VDI/VE 3845, with stainless steel coupling, without mounting console) } <b>TGX:16300-1556</b> The following mounting consoles can be used with the NAMUR part-turn actuator mounting kit 6DR4004-8D. Size W x L x H (H = height of shaft butt) <ul style="list-style-type: none"> <li>30 x 80 x 20 mm } C) <b>TGX:16152-105</b></li> <li>30 x 80 x 30 mm } C) <b>TGX:16300-147</b></li> <li>30 x 130 x 30 mm } C) <b>TGX:16300-149</b></li> </ul>	

### Mounting kit for other part-turn actuators

The following mounting consoles can be used together with the NAMUR part-turn actuator mounting kit 6DR4004-8D.

- SPX (DEZURIK) Power Rac, sizes R1, R1A, R2 and R2A } C) **TGX:16152-328**
- Masoneilan Camflex II } C) **TGX:16152-350**
- Fisher 1051/1052/1061, sizes 30, 40, 60 to 70 } C) **TGX:16152-364**
- Fisher 1051/1052, size 33 } C) **TGX:16152-348**

### Mounting kit for NAMUR linear actuators

- NAMUR linear actuator mounting kit with short lever (2 ... 35 mm (0.08 ... 1.38 inch)) } **6DR4004-8V**
- Short lever for travels from 35 ... 130 mm (1.38 ... 5.12 inch) } **6DR4004-8L**
- Reduced mounting kit for linear actuator (like 6DR4004-8V but without fixing angle and U-bolt), with short lever with up to 35 mm travel (1.38 inch) } **6DR4004-8VK**
- Reduced mounting kit for linear actuator (like 6DR4004-8V but without fixing angle and U-bolt), with long lever with > 35 mm travel (1.38 inch) } **6DR4004-8VL**
- Roll and disk made of stainless steel 316 for replacement of the Teflon roll and aluminum disk in the 6DR4004-8, -8VK and -8VL mounting kits for NAMUR linear actuators } **6DR4004-3N**
- Two terminal blocks made of stainless steel 316 for replacement of the aluminum terminal blocks in the 6DR4004-8V, -8VK and -8VL mounting kits for NAMUR linear actuators } **6DR4004-3M**

### Mounting kit for other linear actuators

- Retrofitting kit for Moore series 72 and 750 valve positioners } C) **TGX:16152-117**
- Masoneilan type 87/88 } C) **TGX:16152-620**
- Fisher type 657/667, size 30 to 80 } C) **TGX:16152-110**
- Samson actuator type 3277 (yoke dimension (H5) = 101 mm<sup>2</sup> (integrated connection without tube), not for Ex d) } C) **6DR4004-8S**

**Connection block**, for safety solenoid valve with extended mounting flange to NAMUR

- For mounting to IEC 534-6 } **6DR4004-1B**
- For SAMSON actuator (integrated mounting) see above } **6DR4004-1C<sup>1)</sup>**

### Pipe mounting

Mounting bracket for pipe mounting of the SIPART PS2 positioner (e. g. when using the NCS sensor) } C) **TGX:16152-336**

**Additional actuator components** can be found at the following Internet address:  
[www.siemens.de/sipartps2](http://www.siemens.de/sipartps2)

Customer-specific mounting kits available on request.

### Documentation (see notes below)

Operating Instructions

- SIPART PS2 HART German **A5E00074630**
- SIPART PS2 HART English **A5E00074631**
- SIPART PS2 PROFIBUS PA German **A5E00127924**
- SIPART PS2 PROFIBUS PA English **A5E00127926**
- SIPART PS2 FOUNDATION Fieldbus German **A5E00214568**
- SIPART PS2 FOUNDATION Fieldbus English **A5E00214569**

SIPART PS2 Compact Instruction Manual

- English, French, German, Spanish, Italian, Dutch **A5E03436620**

- English, Estonian, Latvian, Lithuanian, Polish, Romanian **A5E03436655**

- English, Bulgarian, Czech, Finnish, Slovakian, Slovenian **A5E03436664**

- English, Danish, Greek, Portuguese, Swedish, Hungarian **A5E03436683**

Operating Instructions for NCS Sensor

- German/English/French/Spanish/Italian **A5E00097485**

SIPART PS2 device documentation

- CD-ROM with complete documentation for all device versions **A5E00214567**

**SITRANS I200 output isolator HART** (see "SITRANS I supply units and isolation amplifiers") with

- 24 V DC power supply } **7NG4131-0AA00**

**HART modem** for connecting to PC or laptop

- with RS232 interface } D) **7MF4997-1DA**
- with USB interface } D) **7MF4997-1DB**

} Available ex stock.

<sup>1)</sup> Only together with 6DR4004-8S and 6DR4004-1M.

C) Subject to export regulations AL: N, ECCN: EAR99.

D) Subject to export regulations AL: N, ECCN: EAR99H.

Note:

All the above-mentioned manuals are included on CD-ROM and can be downloaded from [www.siemens.de/sipartps2](http://www.siemens.de/sipartps2).

### Scope of delivery for positioner

- 1 SIPART PS2 positioner as ordered
- 1 CD-ROM with the complete documentation for all versions and accessories
- Manual "SIPART PS2 - Configuration At a Glance"

## Schematics

### Dimensional drawings

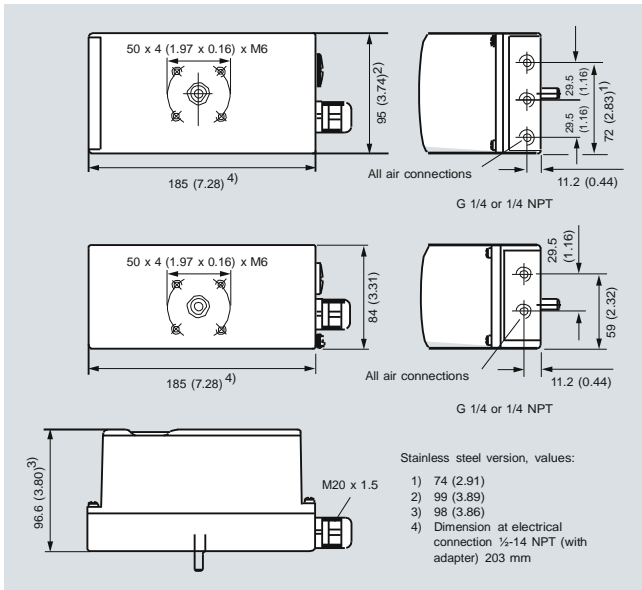

Makrolon and stainless steel enclosure (top), aluminum enclosure (center), Makrolon and aluminum enclosure (bottom), dimensions in mm (inch)

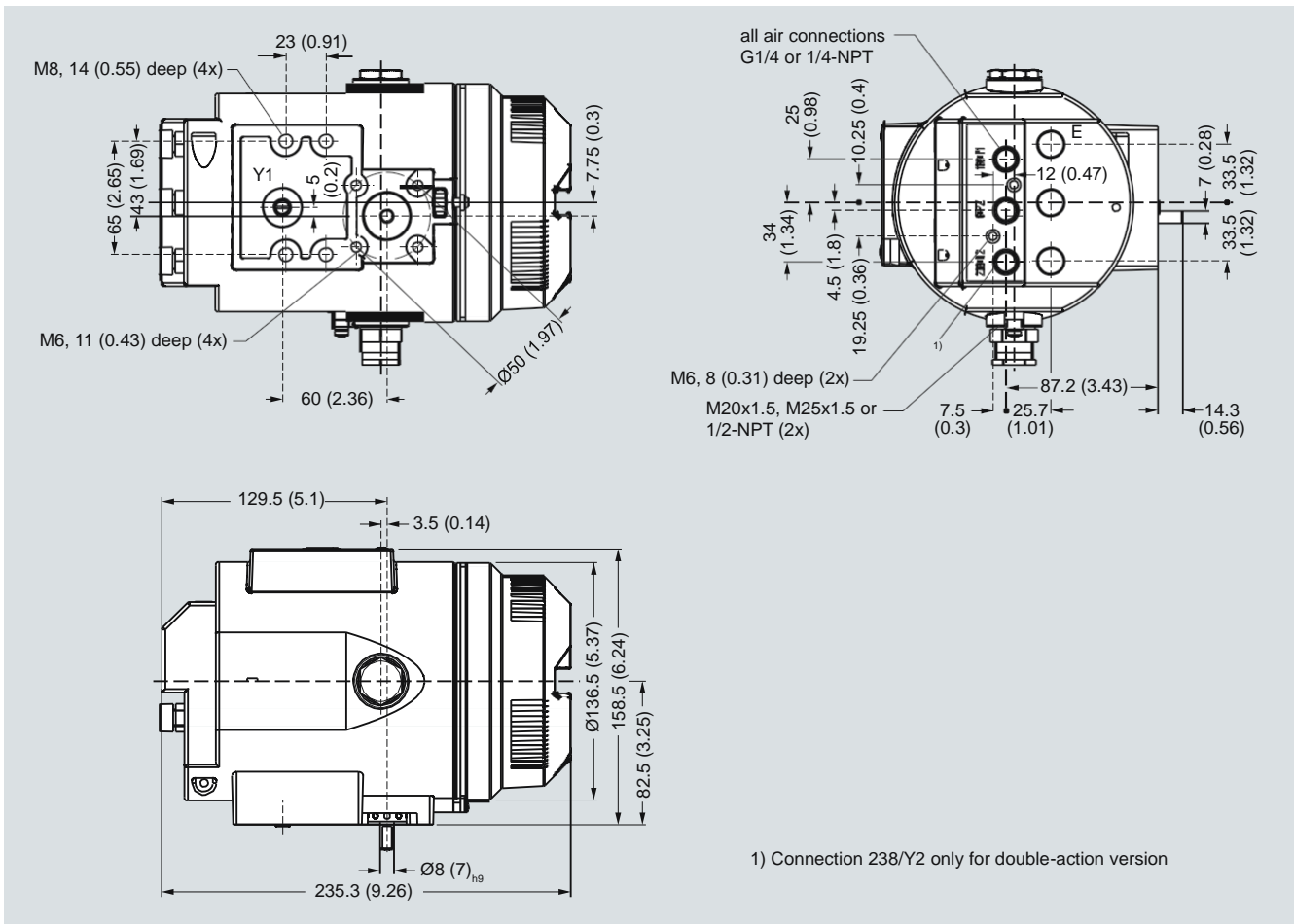

Flameproof enclosure left, dimensions in mm (inch)

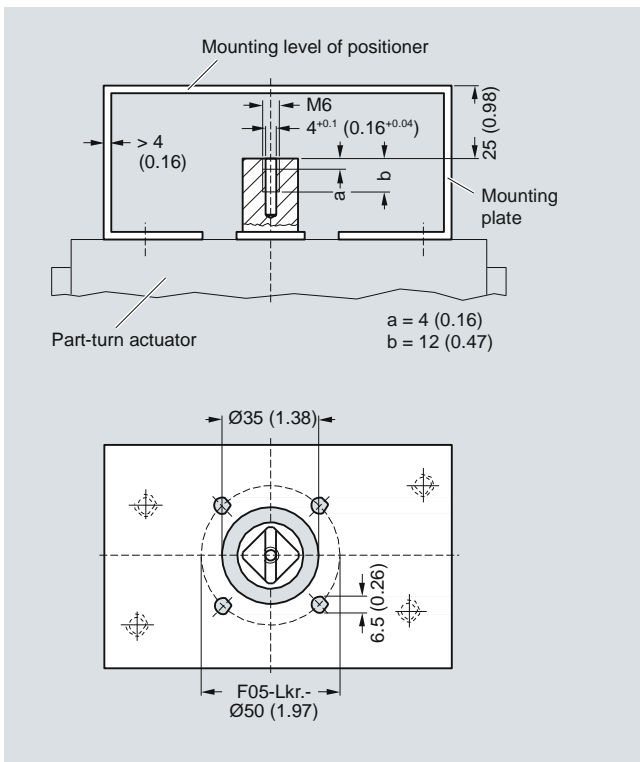

Mounting onto part-turn actuators; mounting consoles (scope of delivery of actuator manufacturer), extract from VDI/VDE 3845, dimensions in mm (inch)

**Schematics**

**Electric connection of 2-wire devices (6DR50.. and 6DR51..)**

Devices of types 6DR50.. and 6DR51.. are operated in a 2-wire system.

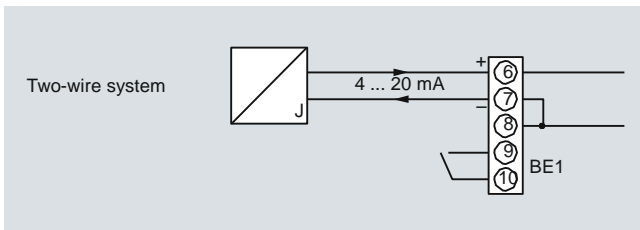

SIPART PS2 electropneumatic positioner, input circuit for 6DR50.. and 6DR51..

**Electric connection of PROFIBUS PA device (6DR55..) and Foundation Fieldbus device (6DR56..)**

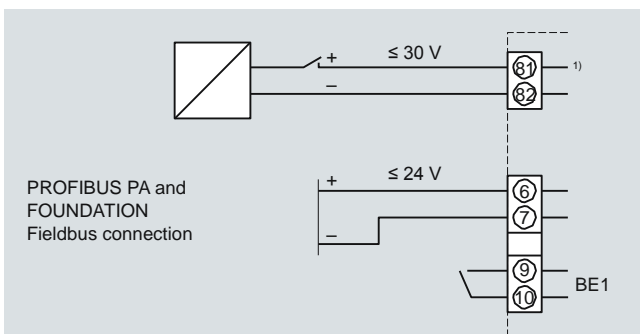

1) Input for safety shutdown (activated using coding jumper)

SIPART PS2 PA and SIPART PS2 FF electropneumatic positioner, input circuit for 6DR55.. and 6DR56..

**Electric connection of 2-, 3- and 4-wire device (6DR52.. and 6DR53..)**

Devices of types 6DR52.. and 6DR53.. can be operated in a 2-, 3- and 4-wire system.

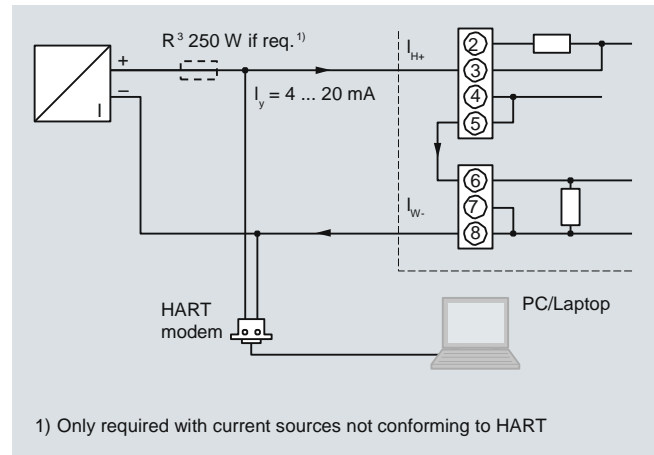

1) Only required with current sources not conforming to HART

SIPART PS2 electropneumatic positioner, example of connection for communication through HART for 6DR52..

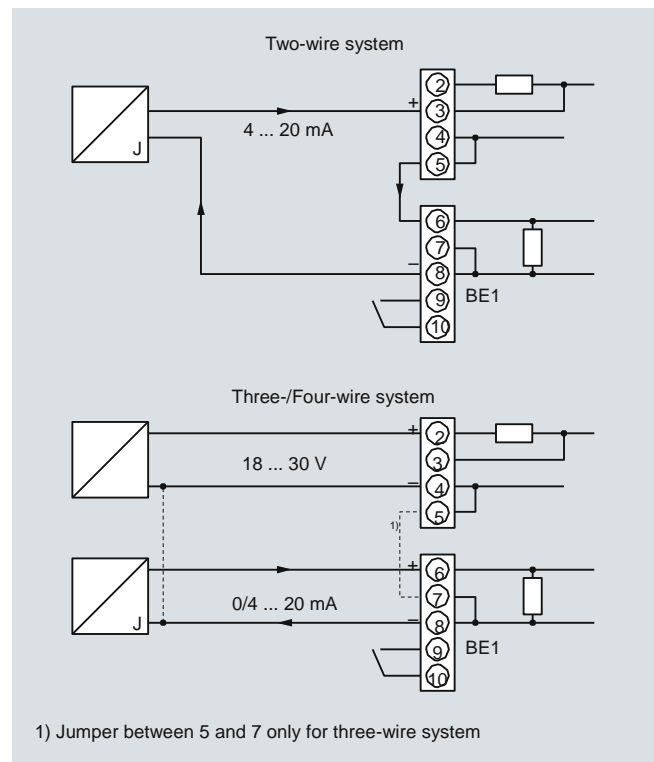

1) Jumper between 5 and 7 only for three-wire system

SIPART PS2 electropneumatic positioner, input circuits for 6DR52.. and 6DR53..

# Positioners

## SIPART PS2

### Mounting kit

#### Mounting kit for NAMUR linear actuators

- 1 mounting bracket
- 2 mounting prisms
- 1 U-bracket
- 1 lever arm with adjustable pick-up roll
- 2 U-bolts
- Various screws and lock washers

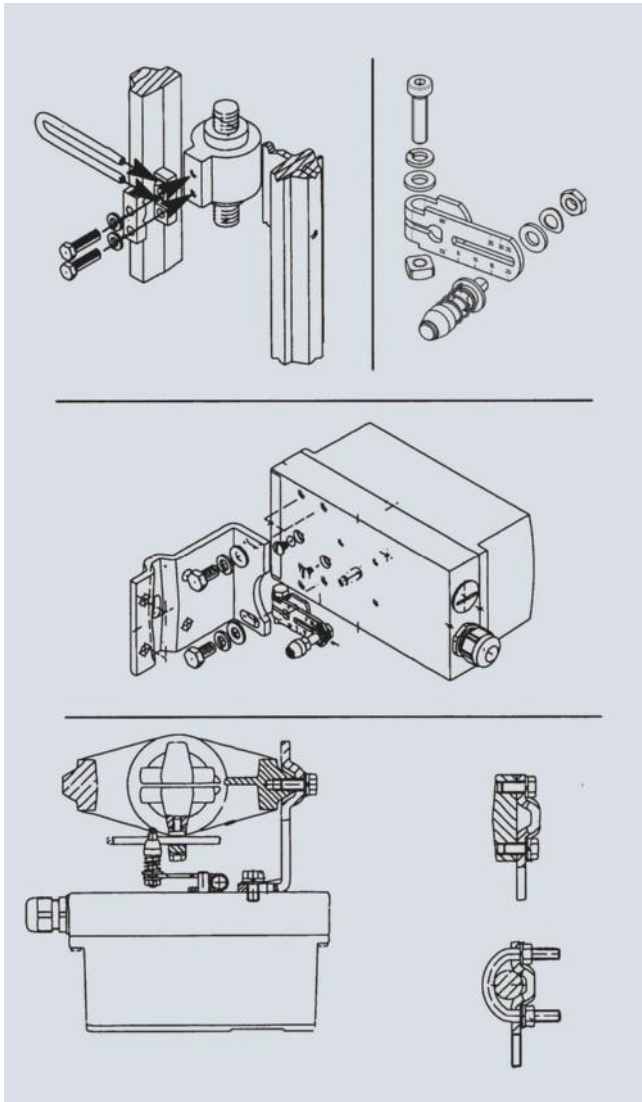

Mounting of SIPART PS2 on linear actuators

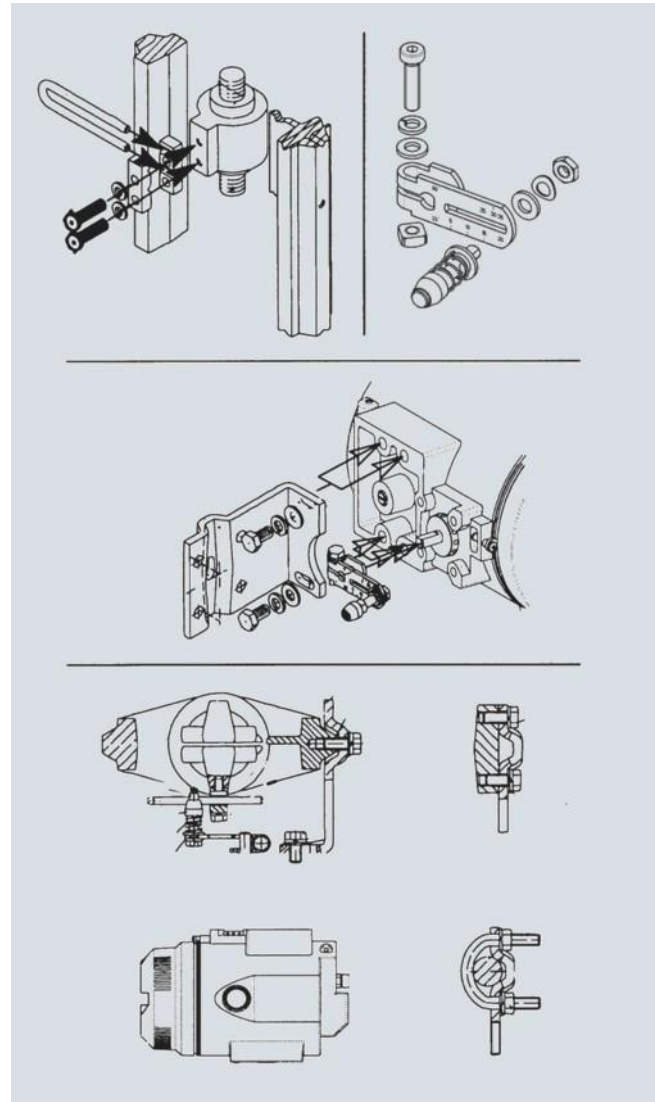

Mounting of SIPART PS2 Ex d on linear actuators

**Mounting kit for NAMUR part-turn actuators**

- 1 coupling wheel
- 1 driver pin
- 8 scales
- 1 pointer
- Various screws and lock washers

Caution: The mounting consoles and the screws for mounting onto the part-turn actuator are not included in the scope of delivery and must be be provided by the customer (see "Technical specifications")

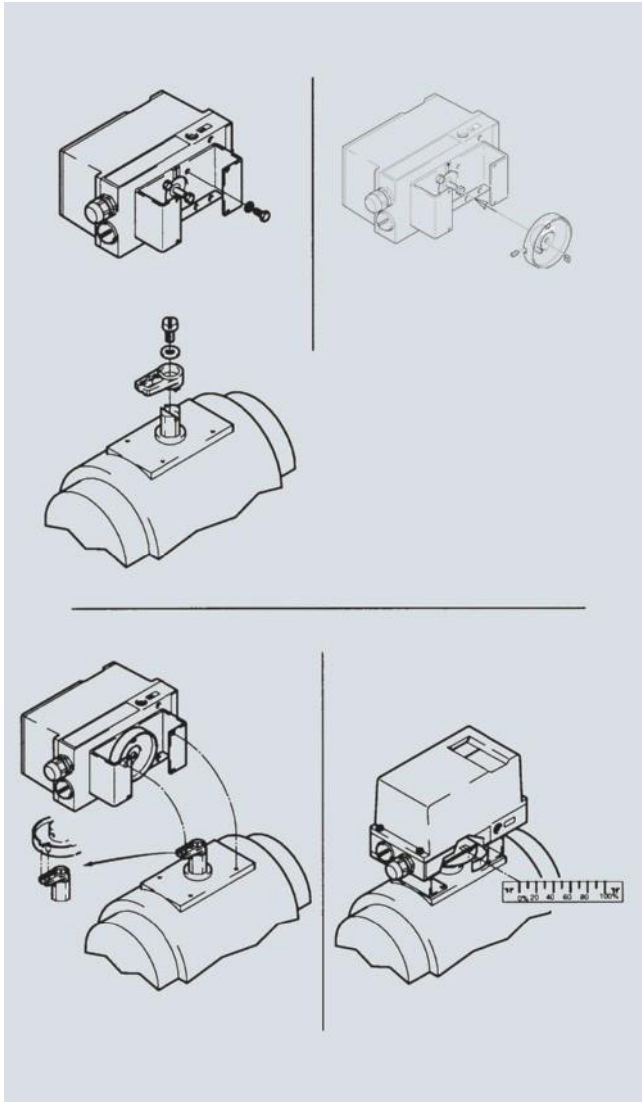

Mounting of SIPART PS2 on part-turn actuators

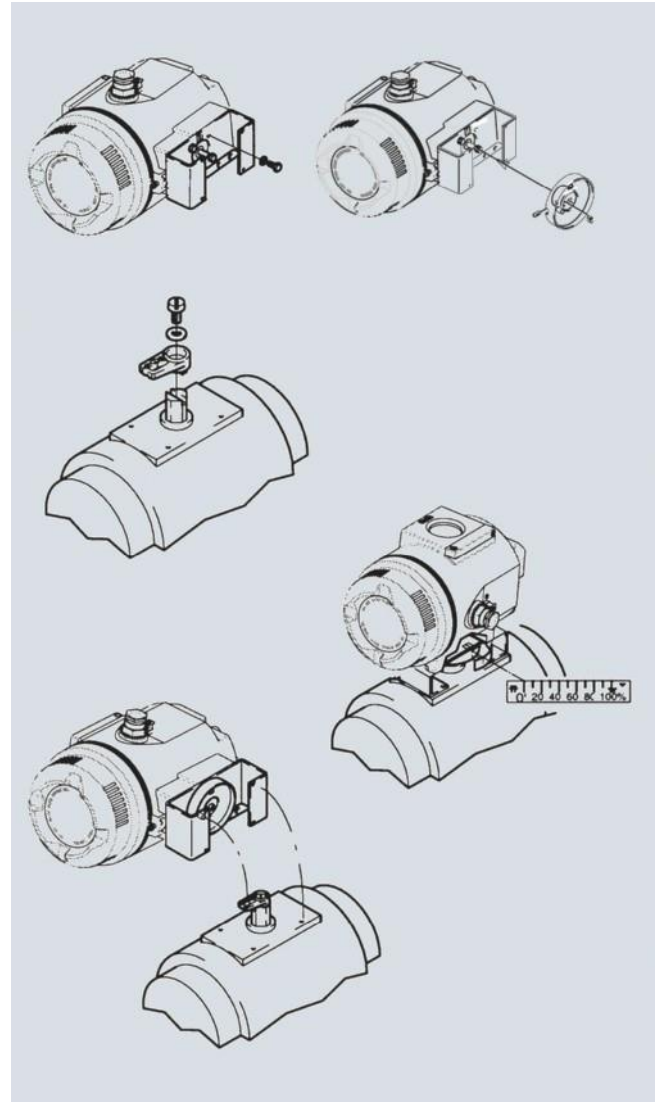

Mounting of SIPART PS2 Ex d on part-turn actuators

**More information**

**Special versions**

On request