

ALGEMENE KENMERKEN:

- Eendelig huis - vlottende kogel - gereduceerde doorlaat - niet-uitdrukbaar spindel
- Anti-static device volgens BS 5351 en ISO 7121
- Drukvereffeningsboring (standaard= 5 mm) in de bovenzijde van de kogel voorkomt overdruk in de ruimte tussen de kogel en het huis
- Alle afsluiters voldoen aan de TA Luft-vereisten
- CE en ATEX markering
- ANSI 150, 1/2" - 10"
- Max. temperaturen: -29°C ~ 230°C (AIT) en -50°C ~ 230°C (IIT)

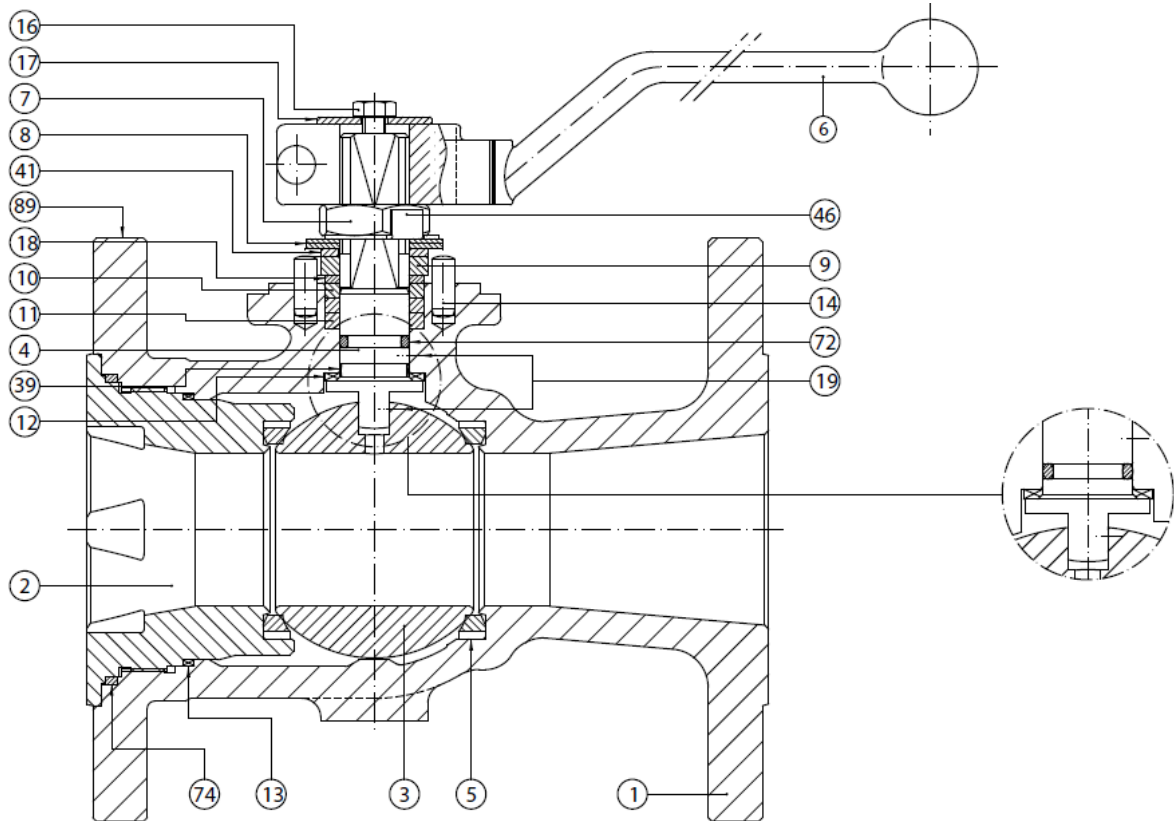

ONTWERP	
Kogelkraan	API 6D, ASME B16.34, EN ISO 17292
Huis	ASME VIII Div.1
Laagdikte	ASME B16.34
Flenzen	ASME B16.5 Raised face
Inbouw lengte	ASME B16.10 short pattern, API 6D, EN 558-2 series 3 & 4
Opbouw flens	ISO 5211
Mediumberoerde onderdelen en bouten	NACE MR.01.75
Afwerking bescherm laag	MSS SP 55
Markering	API 6D, EN ISO 17292, CE-PED, EN 19
TESTEN EN CERTIFICATEN	
Kwaliteit	ISO 9001, API Q1, CE-PED
Fire Safe certificaten	BS 6755 Part 2, API 6FA, ISO 10497, API 607
Druktest	API 598, ISO 5208, EN 12266
Andere	ISO 14001, ATEX



Pos.	Omschrijving	Materialen	
		AIT	IIT
1	Huis	A 216 Gr. WCB (C≤ 0,25%)	A 351 Gr. CF8M
2	Aansluitflens	A 350 Gr. LF2	A 351 Gr. CF8M (DN 15: 40 A 276/479 Tp.316)
3	Kogel	A 351 Gr. CF8M (DN 15 : 25 A 479 Tp.316)	
4	Spindel	A 479 Tp.316	
5	Zitting	PTFE	
6	Handel	Nodulair gietijzer	
7	Spindelmoer	Staal, verzinkt	AISI 303
8	Schotelveer	Staal	Staal, vernikkeld
9	Stopplaat	Staal	AISI 304
10	Pakkingdrukker	AISI 303	AISI 316
11	Pakking	Grafiet	
12	Glijring	25% G.F. PTFE	
13	Huisafdichting	PTFE	
14	Stop	Staal	Roestvaststaal
16	Bout	DIN 933 5.6, verzinkt	DIN 933 A2
17	Rondel	Staal, verzinkt	AISI 304
18	Rondel	25% G.F. PTFE	
19	Antistatic device	Roestvaststaal	
39	Spindelgeleiding (DN 25 t/m DN 200)	25% G.F. PTFE	
41	Rondel (DN 40 t/m DN 200)	Staal	AISI 304
46	Rondel	AISI 304	
72	O-ring	FKM	
74	Insert seal	Grafiet	
89	Identificatieplaat	Roestvaststaal	

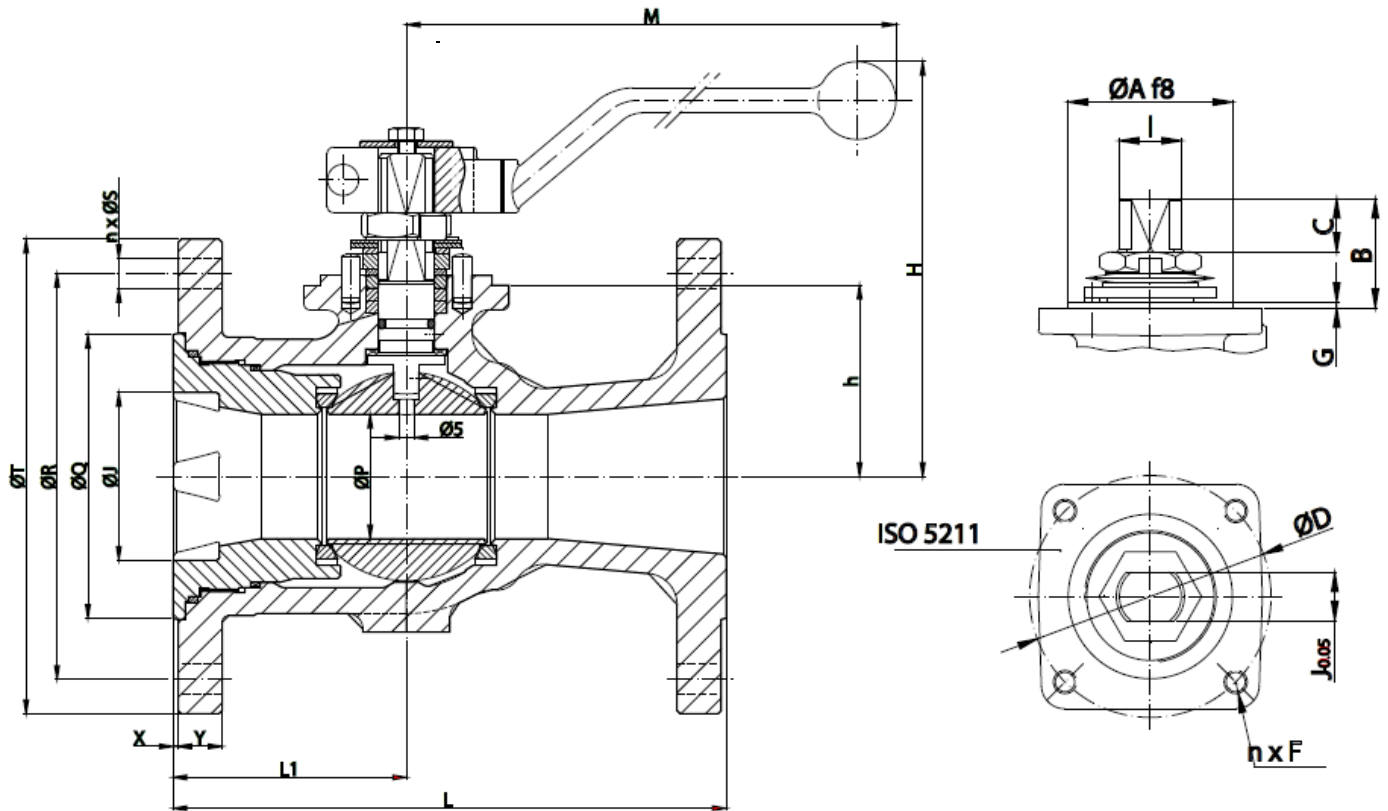

AFMETINGEN: (in mm)

DN	ØJ	ØP	L	L1	ØQ	ØR	n x ØS	ØT	X	Y	h	H	M	Kg
15	15	10	108	54,0	34,9	60,3	4x 15,9	90	1,6	9,5	21,5	81	164	1,6
20	20	15	117	60,0	42,9	69,9	4x 15,9	100	1,6	11,1	26	98	164	2,1
25	25	20	127	65,0	50,8	79,4	4x 15,9	110	1,6	12,7	29	101	164	2,7
40	40	32	165	72,0	73,0	98,4	4x 15,9	125	1,6	15,9	51	117	210	5,1
50	50	40	178	75,1	92,0	120,7	4x 19	150	1,6	17,5	61,5	134	213	7,9
80	79	58	203	88,0	127,0	152,4	4x 19	190	1,6	22,2	76	149	348	14,3
100	102	80	229	104,1	157,2	190,5	8x 19	230	1,6	22,2	92,5	189	445	25,9
150	151	111	267	125,0	216,0	241,3	8x 22,2	280	1,6	23,8	129	227	495	43,8
200	199	144	292	135,0	270,0	298,5	8x 22,2	345	1,6	27,0	158	264	698	77,0
250	254	187	330	165,5	324,0	362	12x 25,4	405	1,6	28,7	191	307	698	114,0

OPBOUWFLENS: (in mm)

DN	ISO	Ø A	B	C	Ø D	n x F	G	I	J
15	F05	35	22,0	8,3	50	4x M6	1,5	M10	7
20	F05	35	22,7	9,0	50	4x M6	3,0	M12	9
25	F05	35	22,7	9,0	50	4x M6	3,0	M12	9
40	F05	35	34,5	14,7	50	4x M6	3,0	M16	12
50	F07	55	41,5	19,2	70	4x M8	3,0	M18	13
80	F07	55	44,0	19,7	70	4x M8	3,0	M22	16
100	F10	70	44,5	19,7	102	4x M10	3,0	M25	18
150	F12	85	56,5	29,2	125	4x M12	3,0	M28	20
200	F12	85	56,0	38,5	125	4x M12	3,0	M34	29
250	F12	85	67,0	39,0	125	4x M12	3,0	M40	32

Wijzigingen voorbehouden

DRUK-TEMPERATUURDIAGRAMMA:

AIT

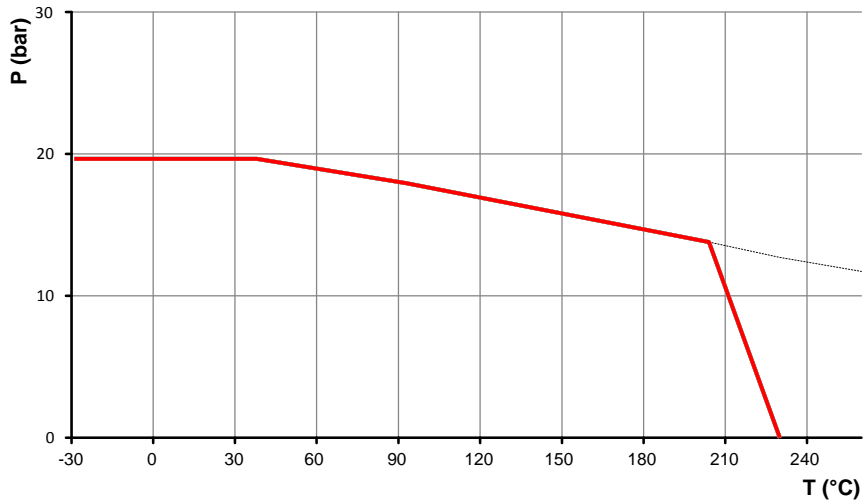

IIT

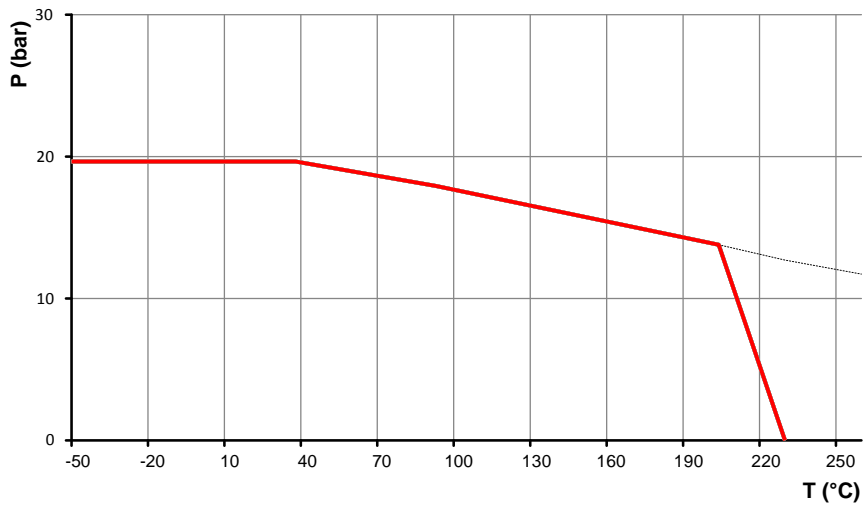

DRAAIMOMENT: (in Nm)

DN	150 Lbs Verschildruk 20 bar
15	6
20	9
25	10
40	21
50	25
80	40
100	90
150	180
200	250
250	600

Kv-WAARDE: (in m³/h)

DN	Kv-waarde
15	7
20	10
25	26
40	107
50	140
80	300
100	600
150	1.000
200	2.000
250	4.100

Wijzigingen voorbehouden