

Two Pieces Ball Valves

1000 WOG (63 bar)

Size ¼" – 4" (DN 10 - 100) Stainless Steel



Serie 2001

FULL BORE

**Threaded according:
DIN 259/2999 (GAS)**

CE

Two Pieces Ball Valves

1000 WOG (63 bar)

Parts and materials, Dimensions

Parts and materials

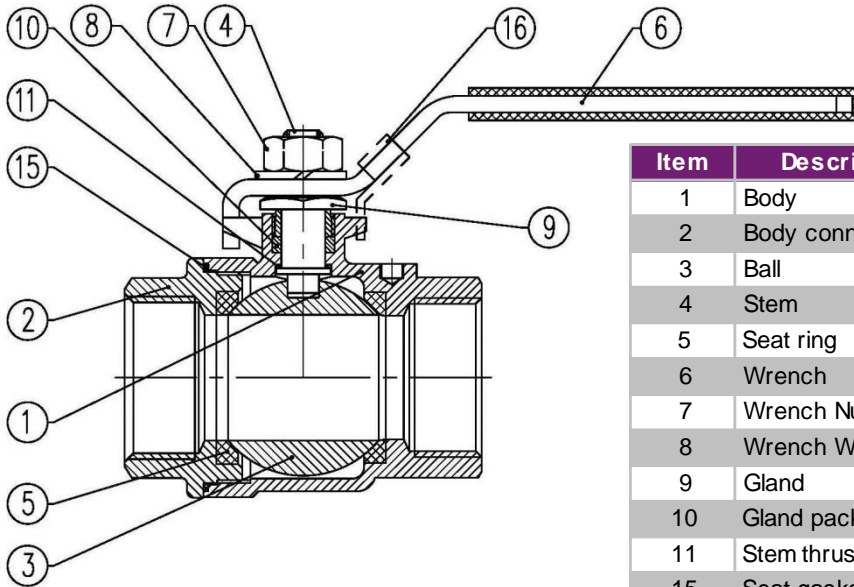

Item	Description	Material
1	Body	1.4408
2	Body connector	1.4408
3	Ball	1.4408
4	Stem	1.4401
5	Seat ring	PTFE
6	Wrench	1.4301
7	Wrench Nut	1.4301
8	Wrench Washer	1.4301
9	Gland	1.4301
10	Gland packing	PTFE
11	Stem thrust seal	PTFE
15	Seat gasket	PTFE
16	Lock device	1.4301

Dimensions

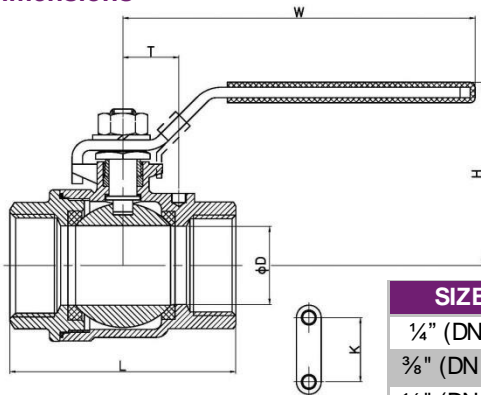

SIZE	NPS	ØD	L	W	K	S	T	H	WEIGHT
¼" (DN 8)	¼"	11,6	50	91	28,5	19	12,5	48	0,195
⅜" (DN 10)	⅜"	12,5	50	91	28,5	21	12,5	48	0,205
½" (DN 15)	½"	15	58	103	28,5	25	13	52	0,29
¾" (DN 20)	¾"	20	65	111	34,8	31	21	61	0,44
1" (DN 25)	1"	25	80	126	34,8	37,5	22,5	65	0,615
1¼" (DN 32)	1¼"	32	92	154	38,1	46	23,5	79	1,08
1½" (DN 40)	1½"	38	105	154	38,1	52,5	23,5	83	1,49
2" (DN 50)	2"	50	125	191	38,1	65	23,5	97	2,56
2½" (DN 65)	2½"	64	155,6	244	56	81	32	129	5,04
3" (DN 80)	3"	76	183	244	56	99	35	138	8,15
4" (DN 100)	4"	94	240	315	63	130	50	175	18,4

Note: (*) Dimensions in mm and weight in kg.
 Dimensions not subject to International Standards can vary in $\pm 10\%$. ICP reserves the right to change those dimensions without notice, due to they do not affect integrity and performance of the valves.

Two Pieces Ball Valves

1000 WOG (63 bar)

Torque, Kv, P&T Rating



DESIGN STANDARDS			
Valves design	EN 1983:2013		
Ends	Threaded according: DIN 259/2999 (GAS)		
TESTS AND CERTIFICATES			
Quality Assurance	ISO 9001		
Pressure testing	EN 12266-1:2012		

Torque Values in Nm

VALVE SIZE	AT DIFFERENTIAL PRESSURE 63 bar	VALVE SIZE	AT DIFFERENTIAL PRESSURE 63 bar
¼" (DN 8)	4	1¼" (DN 32)	14
⅜" (DN 10)	4	1½" (DN 40)	25
½" (DN 15)	5	2" (DN 50)	30
¾" (DN 20)	8	2½" (DN 65)	36
1" (DN 25)	10	3" (DN 80)	60
		4" (DN 100)	95

Kv Values in m³/h

VALVE SIZE	Kv	VALVE SIZE	Kv
¼" (DN 8)	10,0	1¼" (DN 32)	190,0
⅜" (DN 10)	12,0	1½" (DN 40)	275,0
½" (DN 15)	38,0	2" (DN 50)	480,0
¾" (DN 20)	66,0	2½" (DN 65)	797,0
1" (DN 25)	105,0	3" (DN 80)	1210,0
		4" (DN 100)	1300,0

Pressure-Temperature

